

<p>60 Shots</p> 	<p>1: 9.3 →</p> <p>2: 10.1 ←</p> <p>3: 10.4x ↙</p> <p>4: 8.9 →</p> <p>5: 10.0 ↗</p> <p>6: 10.0 →</p> <p>7: 10.2x ↓</p> <p>8: 9.7 ↓</p> <p>9: 10.5x ↗</p> <p>10: 10.8x →</p> <hr/> <p>Series 99.9</p> <p style="text-align: center;">99.9</p>	<p>60 Shots</p> 	<p>11: 10.6x ↓</p> <p>12: 10.4x ↓</p> <p>13: 9.5 ↓</p> <p>14: 10.6x ←</p> <p>15: 10.0 ←</p> <p>16: 9.7 →</p> <p>17: 9.2 →</p> <p>18: 10.2x ↑</p> <p>19: 10.5x ↑</p> <p>20: 10.3x ←</p> <hr/> <p>Series 101.0</p> <p style="text-align: center;">200.9</p>
<p>60 Shots</p> 	<p>21: 10.2x ←</p> <p>22: 10.8x ↓</p> <p>23: 10.2x →</p> <p>24: 10.5x ↓</p> <p>25: 9.9 ↓</p> <p>26: 10.4x ←</p> <p>27: 10.5x ↑</p> <p>28: 10.1 ↑</p> <p>29: 10.5x →</p> <p>30: 10.3x ↑</p> <hr/> <p>Series 103.4</p> <p style="text-align: center;">304.3</p>	<p>60 Shots</p> 	<p>31: 10.1 ↖</p> <p>32: 9.3 ↗</p> <p>33: 9.0 ↑</p> <p>34: 10.0 ↗</p> <p>35: 10.4x ←</p> <p>36: 9.7 ←</p> <p>37: 10.3x ↑</p> <p>38: 10.2x ←</p> <p>39: 9.5 ↗</p> <p>40: 10.6x ↑</p> <hr/> <p>Series 99.1</p> <p style="text-align: center;">403.4</p>
<p>60 Shots</p> 	<p>41: 10.0 →</p> <p>42: 10.3x ↗</p> <p>43: 9.7 →</p> <p>44: 9.9 →</p> <p>45: 10.2x ↗</p> <p>46: 9.6 ←</p> <p>47: 10.0 →</p> <p>48: 9.9 ↗</p> <p>49: 9.9 ↓</p> <p>50: 8.1 ←</p> <hr/> <p>Series 97.6</p> <p style="text-align: center;">501.0</p>	<p>60 Shots</p> 	<p>51: 10.4x ←</p> <p>52: 10.6x ↓</p> <p>53: 10.7x ↓</p> <p>54: 10.4x ↓</p> <p>55: 10.8x ↗</p> <p>56: 10.6x ↖</p> <p>57: 10.3x ↑</p> <p>58: 9.7 ↑</p> <p>59: 10.0 ↑</p> <p>60: 10.2x →</p> <hr/> <p>Series 103.7</p> <p style="text-align: center;">604.7</p>

Relay 6	Lane 3	LYNN Karlie	
1-80		Everett Junior Rifle	Precision
31.01.2025		2025 AirNats by X Count	Civilian Marksmanship Program
Comment		Signature	

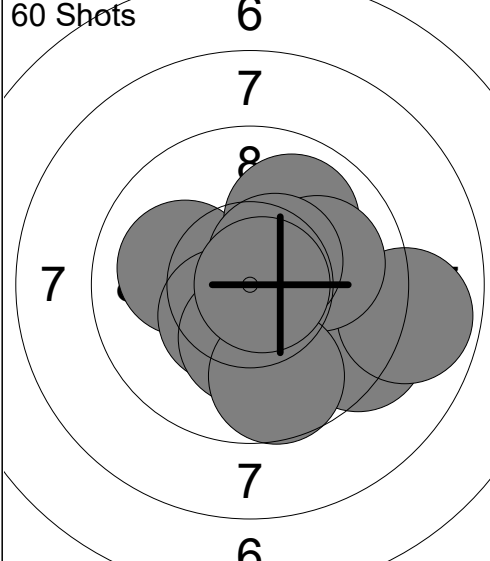

1:	9.9	→
2:	10.2x	↑
3:	10.5x	↗
4:	10.6x	⇒
5:	10.7x	→
6:	9.5	→
7:	10.4x	↖
8:	10.5x	↖
9:	10.4x	↖
10:	10.7x	↗
Series	103.4	
	103.4	

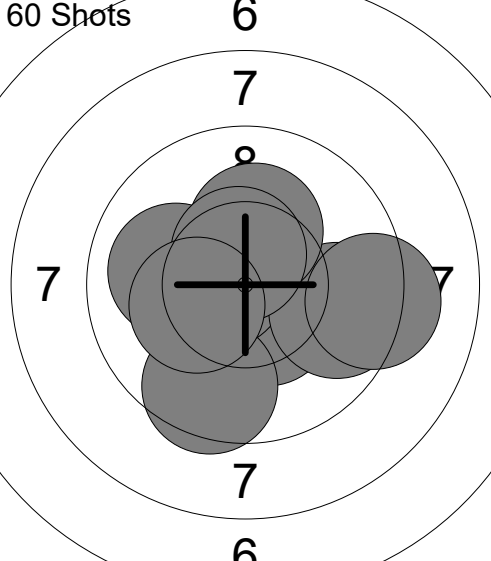
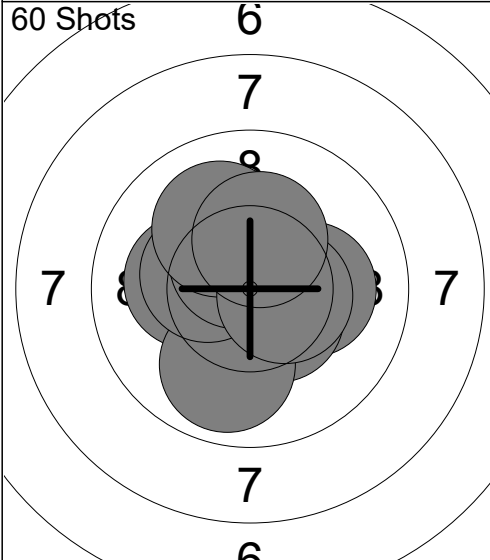
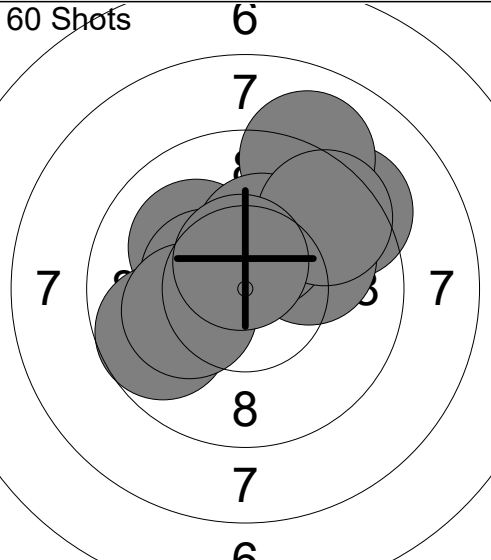
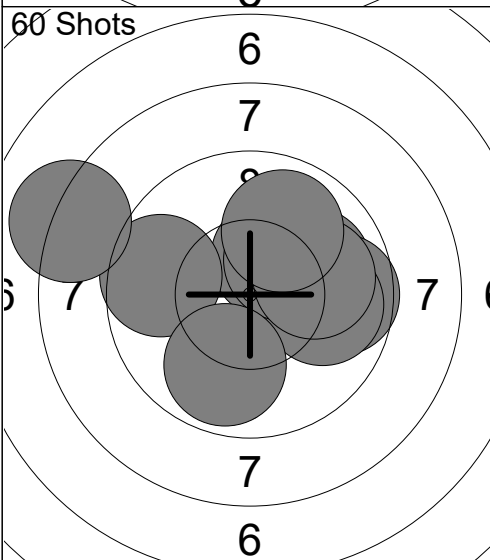
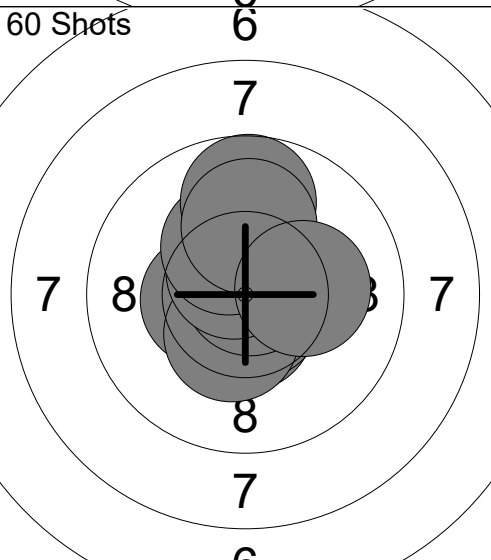
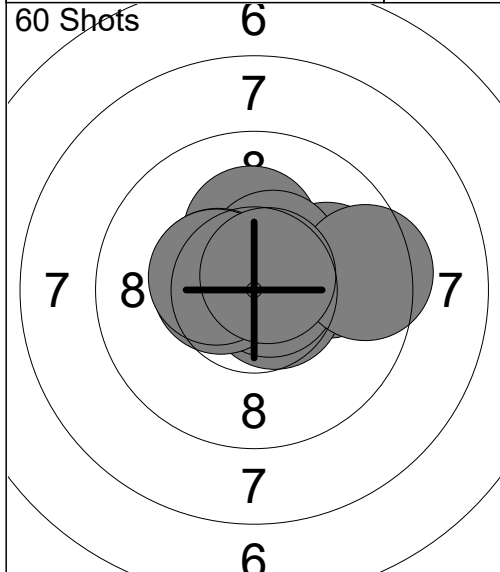
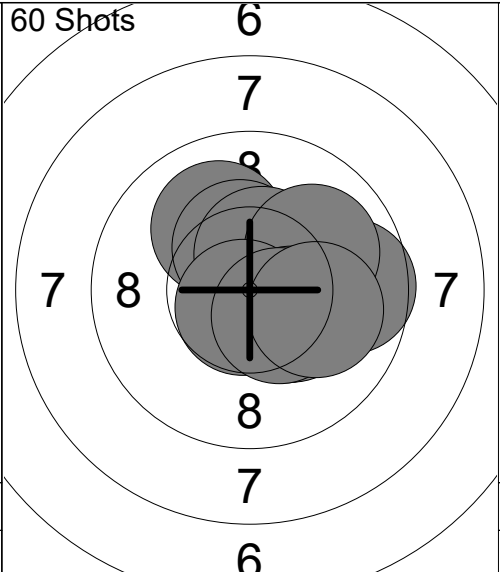

11:	9.6	→
12:	10.0	↖
13:	10.4x	↑
14:	10.5x	↗
15:	10.4x	⇒
16:	10.0	↗
17:	10.7x	↓
18:	10.3x	⇒
19:	10.4x	⇒
20:	10.0	→
Series	102.3	
	205.7	

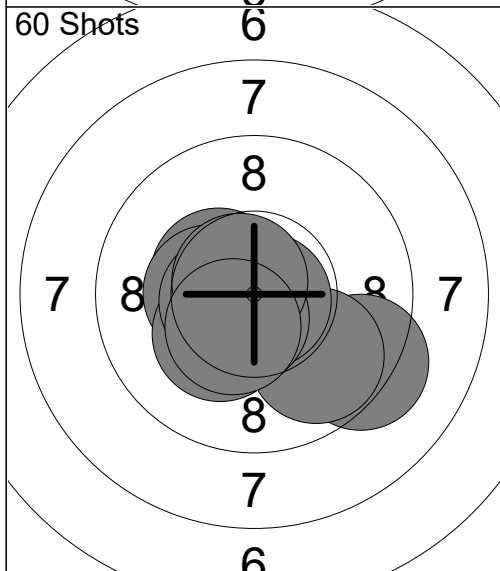

21:	10.4x	↖
22:	10.4x	↖
23:	9.3	⇒
24:	10.3x	↖
25:	9.8	↓
26:	10.8x	⇒
27:	10.6x	↓
28:	10.6x	↖
29:	10.7x	↖
30:	10.4x	↖
Series	103.3	
	309.0	

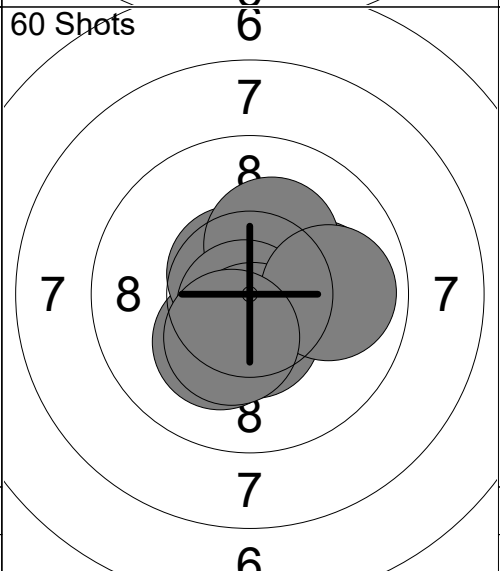

31:	10.1	→
32:	10.5x	↓
33:	10.2x	↖
34:	10.6x	⇒
35:	10.6x	↖
36:	10.2x	↗
37:	10.8x	↓
38:	10.5x	↓
39:	9.9	→
40:	10.3x	↓
Series	103.7	
	412.7	

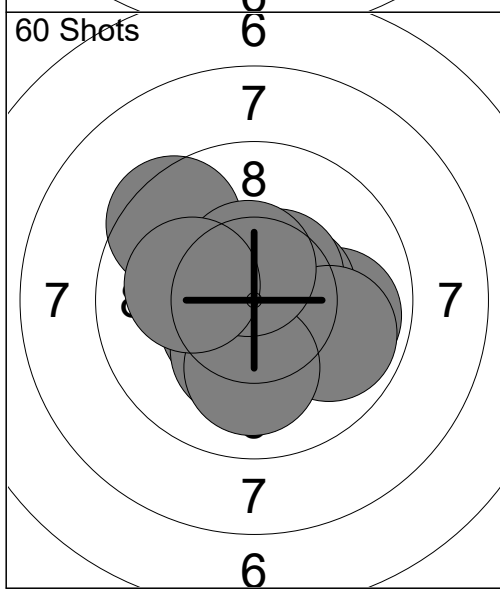

41:	9.9	→
42:	10.5x	→
43:	10.5x	↗
44:	10.5x	↖
45:	10.3x	↓
46:	9.9	→
47:	10.1	↓
48:	9.5	↗
49:	10.5x	↑
50:	10.1	↖
Series	101.8	
	514.5	

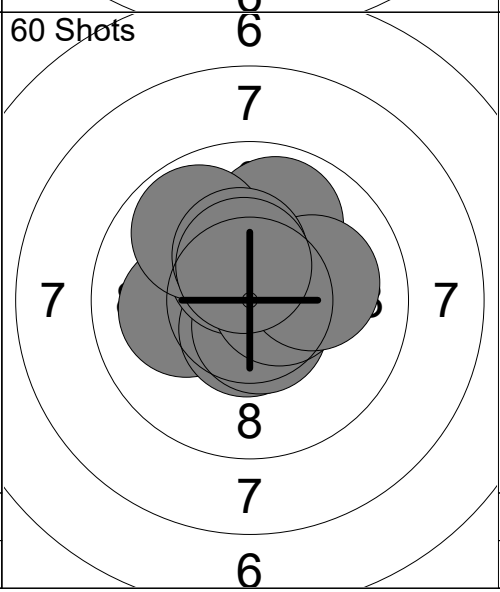

51:	10.1	↖
52:	10.6x	↓
53:	10.6x	↓
54:	10.5x	↖
55:	9.9	↑
56:	10.6x	→
57:	9.8	↖
58:	10.1	→
59:	10.3x	↑
60:	10.5x	↑
Series	103.0	
	617.5	

Relay 6	Lane 4	TEGELER Dierks
--------------------------	-------------------------	-----------------------

1-80	Everett Junior Rifle	Precision	
------	----------------------	-----------	--

31.01.2025	2025 AirNats by X Count	Civilian Marksmanship Program	
------------	-------------------------	-------------------------------	--

Comment	Signature		
---------	-----------	--	--

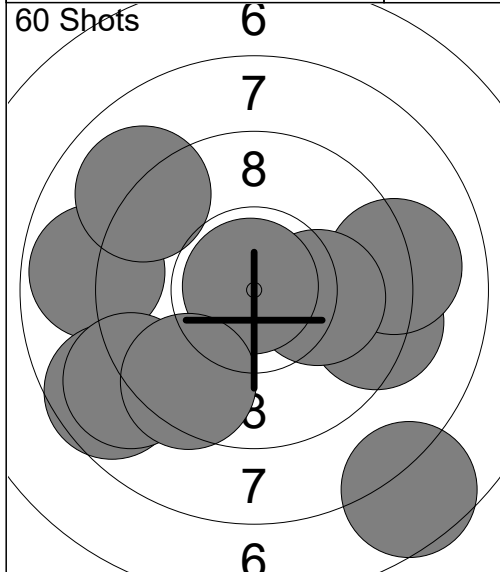

1:	9.3	→
2:	9.1	→
3:	8.9	←
4:	8.6	←
5:	8.9	←
6:	7.6	↓
7:	9.0	↗
8:	10.1	→
9:	10.9x	↗
10:	9.5	↓
Series	91.9	
	91.9	

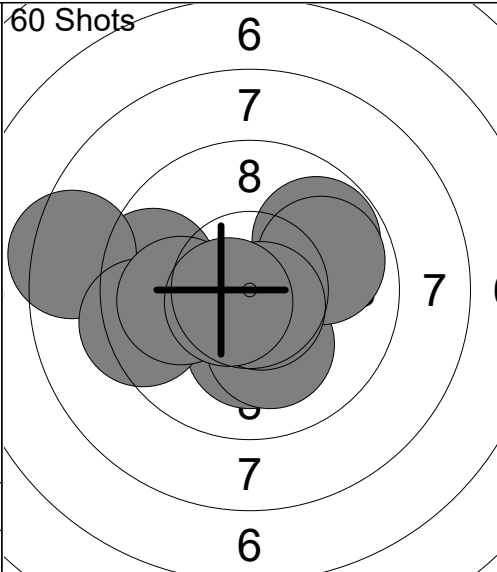

11:	9.8	↗
12:	10.2x	↓
13:	9.6	←
14:	8.4	←
15:	10.1	↓
16:	9.4	←
17:	9.9	↗
18:	10.0	←
19:	10.7x	↓
20:	10.6x	↙
Series	98.7	
	190.6	

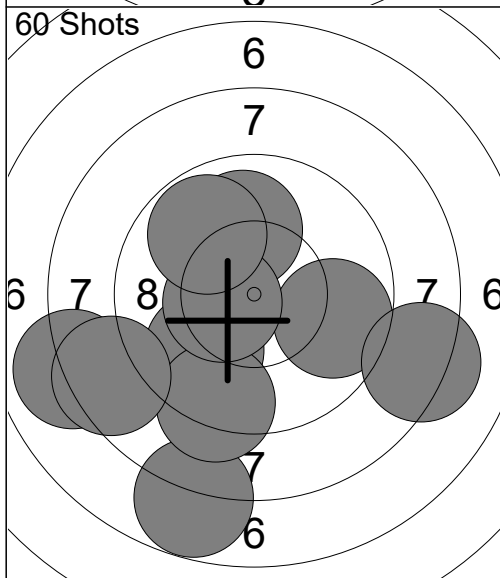

21:	9.7	→
22:	9.8	↓
23:	8.0	←
24:	7.8	↓
25:	8.2	→
26:	9.2	↓
27:	8.5	←
28:	10.0	↑
29:	10.5x	←
30:	9.8	↗
Series	91.5	
	282.1	

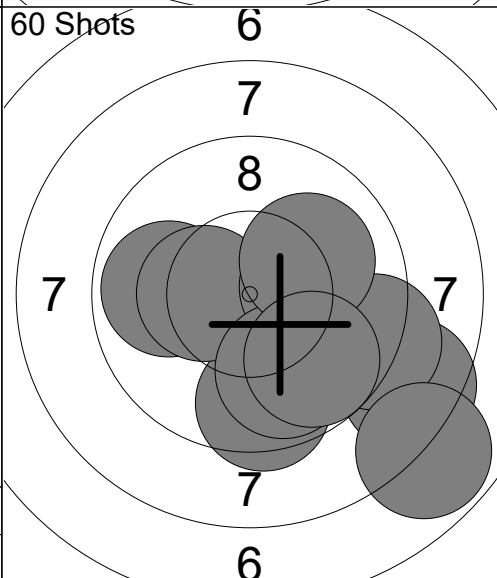

31:	9.9	←
32:	9.5	↓
33:	10.3x	←
34:	8.5	↗
35:	10.2x	→
36:	9.8	↓
37:	9.2	→
38:	7.8	↓
39:	10.1	↗
40:	9.8	↓
Series	95.1	
	377.2	

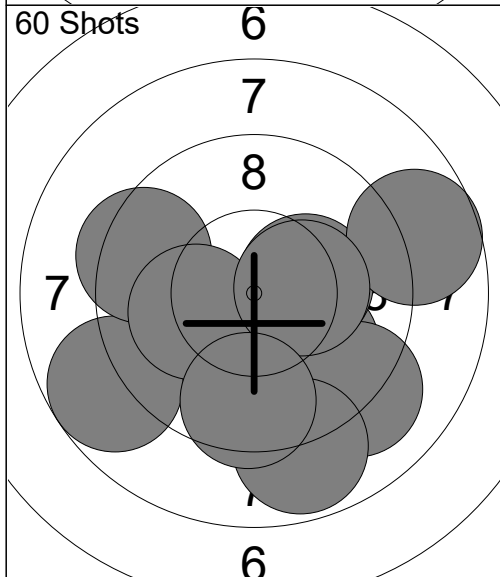

41:	9.9	↓
42:	9.1	↓
43:	10.3x	→
44:	8.7	←
45:	9.4	←
46:	10.1	←
47:	8.8	↓
48:	8.7	→
49:	10.3x	→
50:	9.5	↓
Series	94.8	
	472.0	

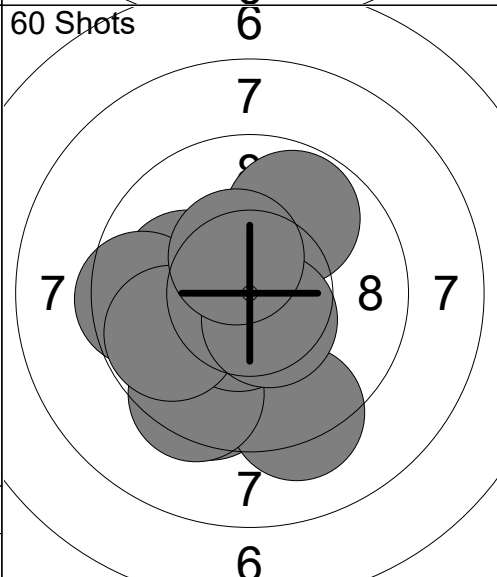

51:	9.5	↓
52:	9.8	↗
53:	10.1	←
54:	9.2	↓
55:	9.4	↓
56:	10.5x	↓
57:	9.5	←
58:	9.8	←
59:	10.5x	↓
60:	10.4x	↗
Series	98.7	
	570.7	

<p>60 Shots</p>	<p>1: 10.6x ↑ 2: 10.5x ↑ 3: 10.0 → 4: 9.7 ↖ 5: 10.7x ↑ 6: 10.7x ↓ 7: 10.4x ↑ 8: 10.5x → 9: 10.4x ← 10: 9.2 ←</p> <p>Series 102.7 102.7</p>	<p>60 Shots</p>	<p>11: 10.4x ↓ 12: 10.7x ↓ 13: 10.0 → 14: 10.3x ↖ 15: 10.2x ↗ 16: 10.2x ↖ 17: 10.5x ↗ 18: 10.3x ↖ 19: 9.7 ← 20: 10.3x ↖</p> <p>Series 102.6 205.3</p>
<p>60 Shots</p>	<p>21: 10.2x ← 22: 9.7 ↖ 23: 10.5x ↗ 24: 9.8 ↑ 25: 10.5x → 26: 10.2x ↑ 27: 9.8 ↗ 28: 10.4x → 29: 9.4 ← 30: 10.1 ↗</p> <p>Series 100.6 305.9</p>	<p>60 Shots</p>	<p>31: 10.5x ↖ 32: 10.0 ↓ 33: 10.1 ← 34: 10.3x ↓ 35: 10.2x ← 36: 9.7 → 37: 9.7 ↗ 38: 10.5x → 39: 10.3x ↓ 40: 9.9 ↓</p> <p>Series 101.2 407.1</p>
<p>60 Shots</p>	<p>41: 9.6 → 42: 10.2x ↗ 43: 10.2x ← 44: 10.2x ← 45: 9.9 ↓ 46: 10.5x ← 47: 10.8x ↓ 48: 9.8 ↓ 49: 9.9 → 50: 10.7x ←</p> <p>Series 101.8 508.9</p>	<p>60 Shots</p>	<p>51: 9.9 ↗ 52: 10.3x → 53: 9.0 ← 54: 10.7x ↓ 55: 9.9 ↓ 56: 10.6x ↑ 57: 10.6x ↓ 58: 10.6x ← 59: 9.6 → 60: 10.1 ↗</p> <p>Series 101.3 610.2</p>

Relay 6	Lane 6	MILLS Laila	
1-80	Everett Junior Rifle	Precision	
31.01.2025	2025 AirNats by X Count	Civilian Marksmanship Program	
Comment	Signature		

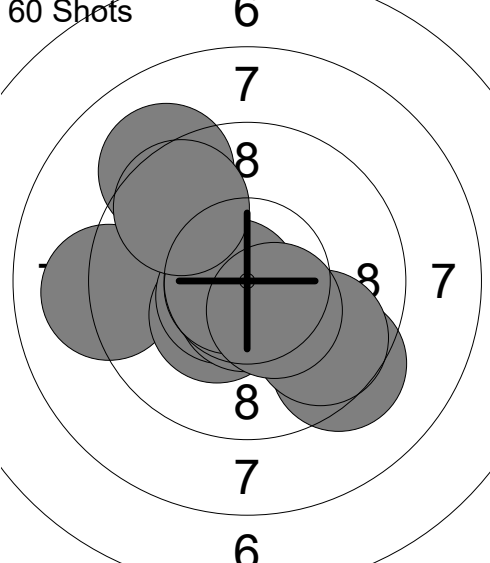
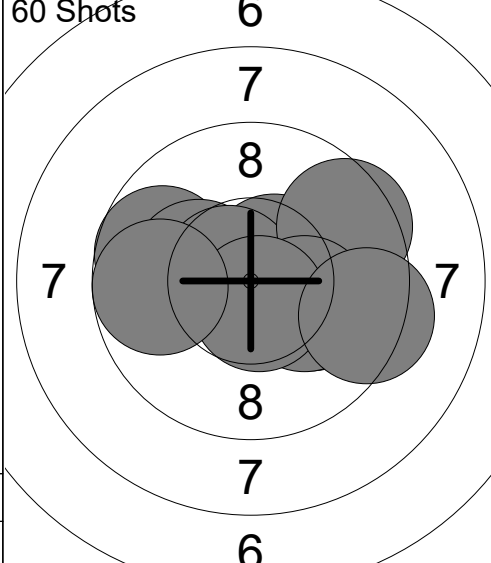
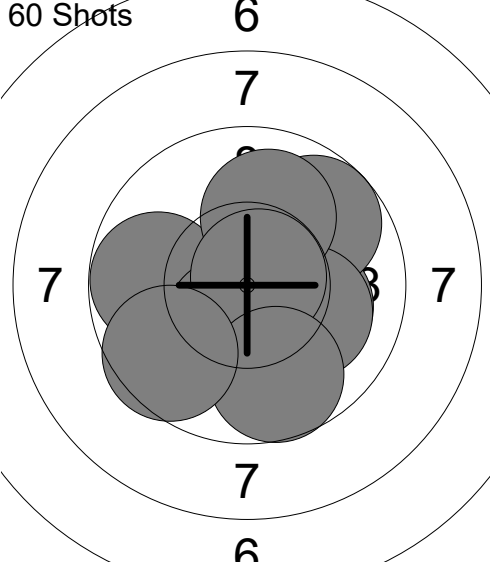
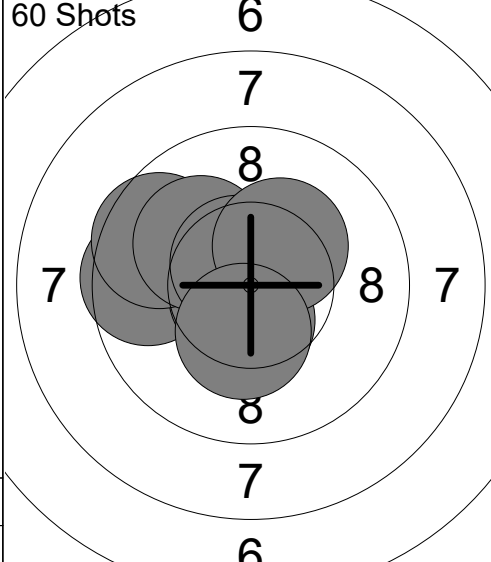
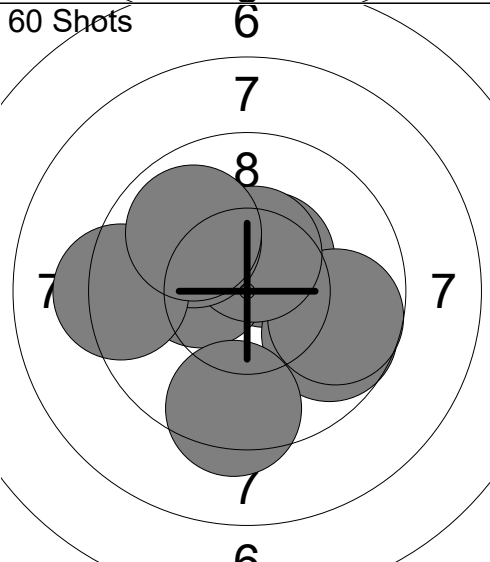
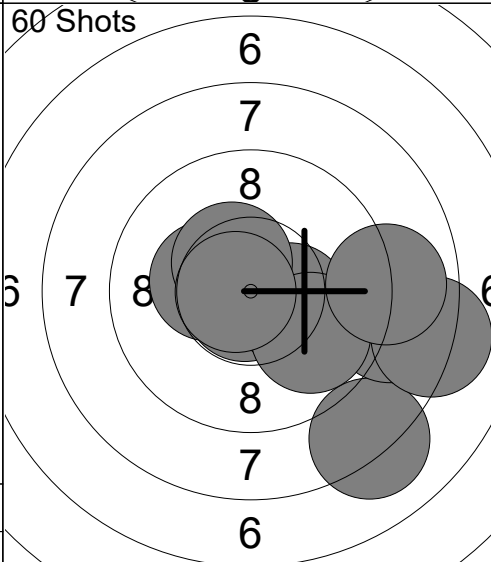
60 Shots 6 	1: 9.3 ↘ 2: 9.1 ← 3: 10.3x ↙ 4: 10.6x ↙ 5: 9.7 ↘ 6: 10.7x ↓ 7: 10.7x ← 8: 10.4x ↘ 9: 9.1 ↗ 10: 9.6 ↗	60 Shots 6 	11: 9.7 ← 12: 10.6x ↗ 13: 10.2x ← 14: 10.6x ← 15: 10.1 → 16: 9.5 ↗ 17: 10.2x → 18: 10.6x ↓ 19: 9.4 → 20: 9.7 ←
Series 99.5	Series 100.6	Series 99.5	Series 100.6
60 Shots 6 	21: 9.8 ← 22: 10.1 → 23: 10.4x → 24: 9.8 ↗ 25: 10.1 → 26: 10.0 ↑ 27: 10.4x ↓ 28: 10.8x ↗ 29: 9.7 ↓ 30: 9.6 ↙	60 Shots 6 	31: 10.9x ↙ 32: 10.6x ↑ 33: 9.6 ← 34: 10.5x ↓ 35: 10.7x ↙ 36: 9.6 ← 37: 10.1 ↗ 38: 10.6x ↗ 39: 10.3x ↗ 40: 10.3x ↓
Series 100.7	Series 103.2	Series 100.7	Series 103.2
60 Shots 6 	41: 10.5x ↗ 42: 10.2x ↗ 43: 10.3x ← 44: 9.7 → 45: 9.7 → 46: 10.5x ↑ 47: 10.0 ↗ 48: 9.3 ← 49: 9.9 ↗ 50: 9.4 ↓	60 Shots 6 	51: 10.8x ↙ 52: 8.1 ↘ 53: 8.8 → 54: 10.3x → 55: 10.3x ← 56: 9.9 ↘ 57: 8.2 → 58: 8.9 → 59: 10.4x ↗ 60: 10.7x ←
Series 99.5	Series 96.4	Series 99.5	Series 96.4
503.5	599.9	503.5	599.9

Relay 6	Lane 7	CURTIS Ava
-------------------	------------------	-------------------

1-80	NTCSC Citius	Precision	
------	--------------	-----------	--

31.01.2025	2025 AirNats by X Count	Civilian Marksmanship Program	
------------	-------------------------	-------------------------------	--

Comment	Signature		
---------	-----------	--	--

<p>60 Shots</p> <p style="text-align: center;">6 7 8 7 7 7 8 8 7 7</p>	<p>1: 9.7 →</p> <p>2: 10.2x ↗</p> <p>3: 10.2x ↑</p> <p>4: 10.2x ↑</p> <p>5: 10.5x ↘</p> <p>6: 10.1 ←</p> <p>7: 10.1 ←</p> <p>8: 10.3x ↓</p> <p>9: 10.2x →</p> <p>10: 10.3x ↘</p> <hr/> <p>Series 101.8</p> <hr/> <p style="text-align: center;">101.8</p>	<p>60 Shots</p> <p style="text-align: center;">6 7 8 7 7 7 8 8 7 7</p>	<p>11: 9.9 ←</p> <p>12: 9.8 ←</p> <p>13: 10.1 ↙</p> <p>14: 10.0 ↗</p> <p>15: 10.4x ↑</p> <p>16: 10.0 →</p> <p>17: 10.3x ↖</p> <p>18: 9.9 ↖</p> <p>19: 10.3x →</p> <p>20: 10.5x ↖</p> <hr/> <p>Series 101.2</p> <hr/> <p style="text-align: center;">203.0</p>
<p>60 Shots</p> <p style="text-align: center;">6 7 8 7 7 7 8 8 7 7</p>	<p>21: 10.2x →</p> <p>22: 10.8x ←</p> <p>23: 10.5x ↖</p> <p>24: 9.9 →</p> <p>25: 10.0 →</p> <p>26: 10.3x →</p> <p>27: 10.7x ↗</p> <p>28: 10.8x →</p> <p>29: 10.7x ←</p> <p>30: 10.5x ↘</p> <hr/> <p>Series 104.4</p> <hr/> <p style="text-align: center;">307.4</p>	<p>60 Shots</p> <p style="text-align: center;">6 7 8 7 7 7 8 8 7 7</p>	<p>31: 10.1 →</p> <p>32: 10.6x →</p> <p>33: 10.9x →</p> <p>34: 10.2x ↗</p> <p>35: 10.4x ←</p> <p>36: 10.6x ↑</p> <p>37: 9.7 →</p> <p>38: 10.1 ↗</p> <p>39: 10.7x ←</p> <p>40: 9.5 →</p> <hr/> <p>Series 102.8</p> <hr/> <p style="text-align: center;">410.2</p>
<p>60 Shots</p> <p style="text-align: center;">6 7 8 7 7 7 8 8 7 7</p>	<p>41: 9.7 →</p> <p>42: 9.8 ←</p> <p>43: 9.2 ↘</p> <p>44: 10.6x ↑</p> <p>45: 10.6x ↑</p> <p>46: 10.3x →</p> <p>47: 10.4x ←</p> <p>48: 10.7x ↑</p> <p>49: 10.6x ↗</p> <p>50: 10.3x →</p> <hr/> <p>Series 102.2</p> <hr/> <p style="text-align: center;">512.4</p>	<p>60 Shots</p> <p style="text-align: center;">6 7 8 7 7 7 8 8 7 7</p>	<p>51: 10.7x ↓</p> <p>52: 10.0 ↘</p> <p>53: 10.3x ←</p> <p>54: 10.7x →</p> <p>55: 10.5x →</p> <p>56: 10.5x ↙</p> <p>57: 10.4x →</p> <p>58: 10.5x ←</p> <p>59: 10.5x →</p> <p>60: 10.7x →</p> <hr/> <p>Series 104.8</p> <hr/> <p style="text-align: center;">617.2</p>

<p>60 Shots</p>	<p>1: 10.3x ↓ 2: 10.5x ↓ 3: 10.5x ↑ 4: 10.5x ↓ 5: 9.9 → 6: 10.4x ↑ 7: 9.6 ↗ 8: 10.3x → 9: 10.4x ↓ 10: 10.1 ↑</p> <p>Series 102.5</p>	<p>60 Shots</p>	<p>11: 9.8 ↑ 12: 8.5 → 13: 9.5 ↓ 14: 10.2x ↑ 15: 10.0 ↖ 16: 9.6 ↓ 17: 10.1 ↑ 18: 10.0 ↓ 19: 10.4x → 20: 9.6 ←</p> <p>Series 97.7</p>
	102.5		200.2
<p>60 Shots</p>	<p>21: 9.9 ↓ 22: 8.9 → 23: 9.6 → 24: 10.7x → 25: 10.6x ← 26: 10.5x ↖ 27: 9.9 → 28: 10.6x ← 29: 9.7 ↓ 30: 10.1 ↓</p> <p>Series 100.5</p>	<p>60 Shots</p>	<p>31: 10.0 ← 32: 9.7 ↓ 33: 9.4 ↖ 34: 10.1 ↑ 35: 10.1 ↓ 36: 9.6 ↓ 37: 10.3x → 38: 10.3x ↓ 39: 10.3x ↖ 40: 9.8 ↓</p> <p>Series 99.6</p>
	300.7		400.3
<p>60 Shots</p>	<p>41: 9.7 ← 42: 10.3x ↓ 43: 9.3 ↗ 44: 9.4 → 45: 9.8 ↗ 46: 10.4x ↓ 47: 10.4x ← 48: 10.1 ↓ 49: 9.8 ↓ 50: 10.2x →</p> <p>Series 99.4</p>	<p>60 Shots</p>	<p>51: 9.6 ← 52: 9.5 → 53: 10.4x ↓ 54: 10.3x ↑ 55: 10.1 ← 56: 10.2x ↖ 57: 10.3x ← 58: 10.6x ← 59: 10.2x ← 60: 10.6x ↑</p> <p>Series 101.8</p>
	499.7		601.5

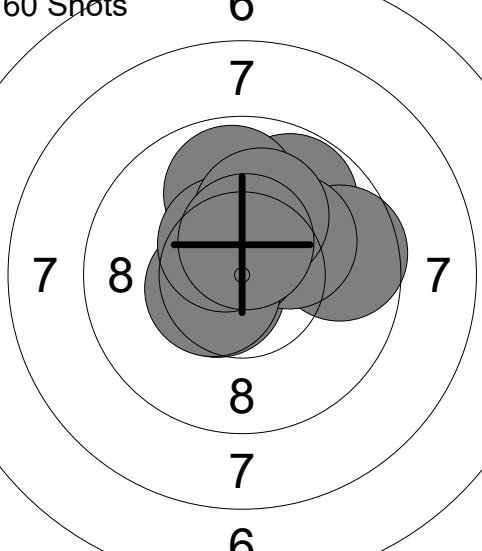
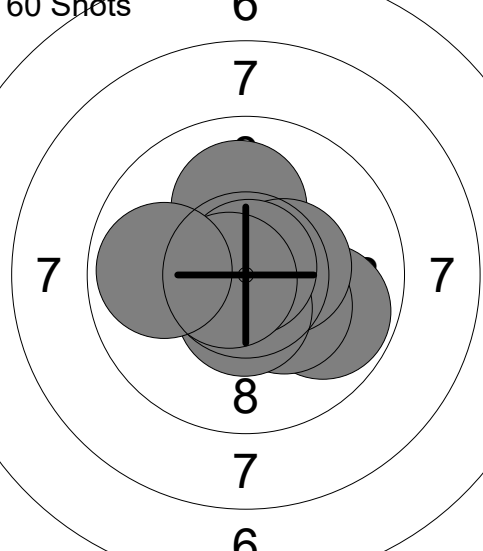
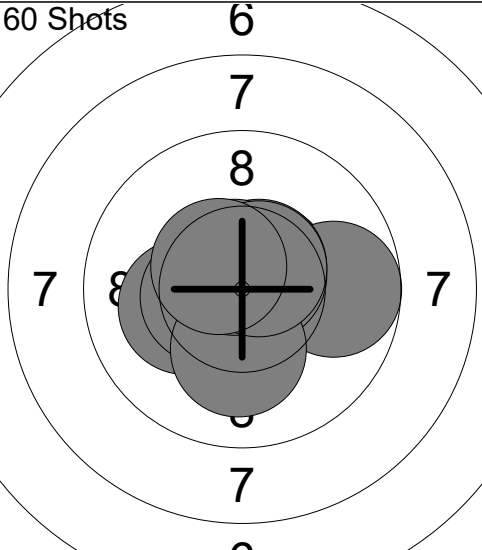
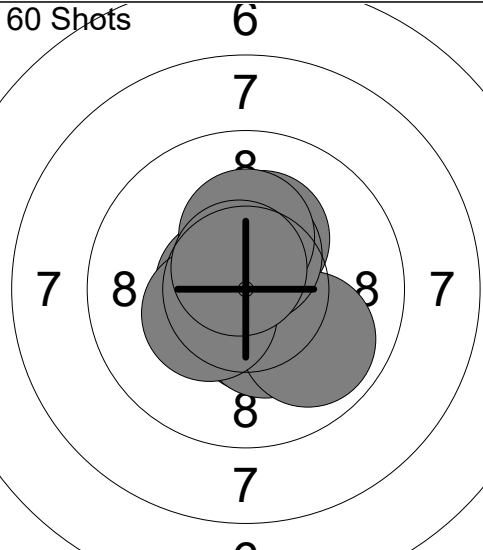
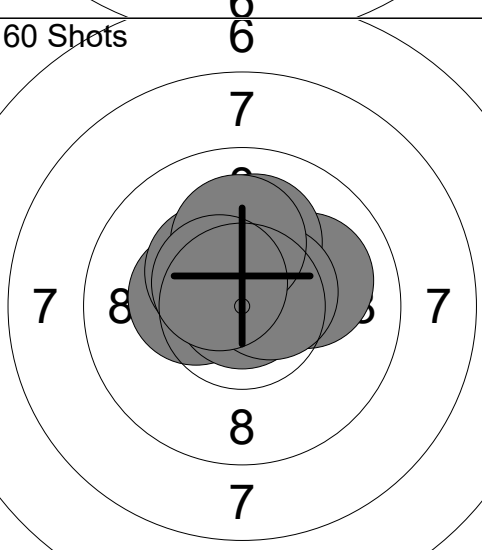
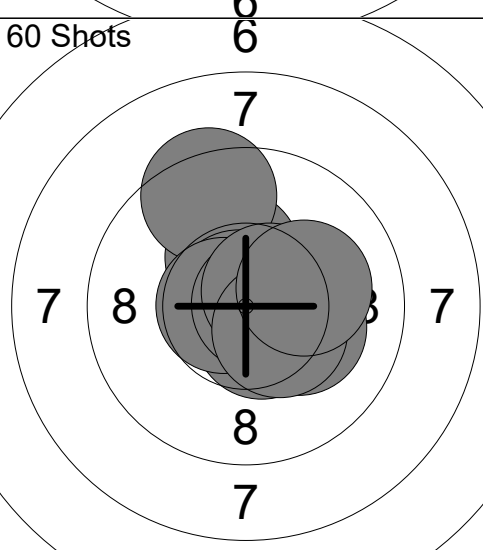
<p>60 Shots</p> 	<p>1: 9.8 ↗ 2: 9.6 → 3: 10.6x ↙ 4: 10.2x ↗ 5: 9.9 ↑ 6: 10.6x ↖ 7: 10.5x ↙ 8: 10.5x ↖ 9: 10.1 ↑ 10: 10.5x ↑</p> <p>Series 102.3 102.3</p>	<p>60 Shots</p> 	<p>11: 10.7x ↑ 12: 10.1 ↑ 13: 9.8 ⇒ 14: 10.3x ⇒ 15: 10.7x ↘ 16: 10.4x → 17: 10.5x ↓ 18: 10.8x ↑ 19: 10.7x ← 20: 9.9 ←</p> <p>Series 103.9 206.2</p>
<p>60 Shots</p> 	<p>21: 10.6x ↗ 22: 9.7 → 23: 10.7x ↗ 24: 10.2x ← 25: 10.6x ↗ 26: 10.5x ← 27: 10.2x ↓ 28: 10.6x ↖ 29: 10.6x ↗ 30: 10.5x ↖</p> <p>Series 104.2 310.4</p>	<p>60 Shots</p> 	<p>31: 10.6x ← 32: 10.6x ↙ 33: 10.4x ↓ 34: 10.2x ↑ 35: 10.3x ↓ 36: 9.9 ⇒ 37: 10.4x ↙ 38: 10.5x ↑ 39: 10.3x ↑ 40: 10.7x ↖</p> <p>Series 103.9 414.3</p>
<p>60 Shots</p> 	<p>41: 10.3x ← 42: 10.3x ↖ 43: 10.5x ↗ 44: 10.0 → 45: 10.9x ↑ 46: 10.1 ↑ 47: 10.3x ↑ 48: 10.5x ↗ 49: 10.1 ↑ 50: 10.5x ↖</p> <p>Series 103.5 517.8</p>	<p>60 Shots</p> 	<p>51: 10.3x ↑ 52: 9.4 ↑ 53: 10.6x ↓ 54: 10.8x ↖ 55: 10.7x ← 56: 10.8x → 57: 10.6x ↗ 58: 10.2x ⇒ 59: 10.4x ⇒ 60: 10.1 →</p> <p>Series 103.9 621.7</p>

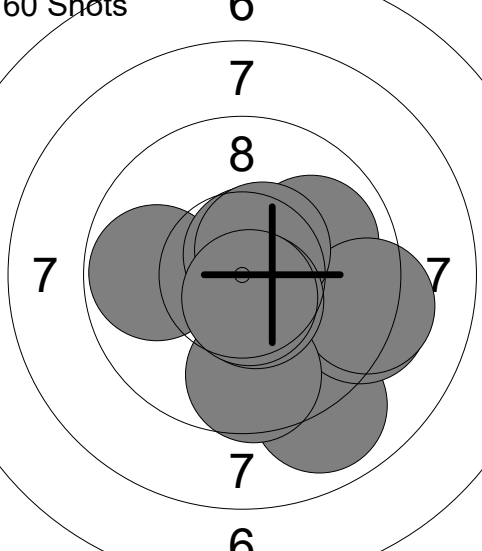
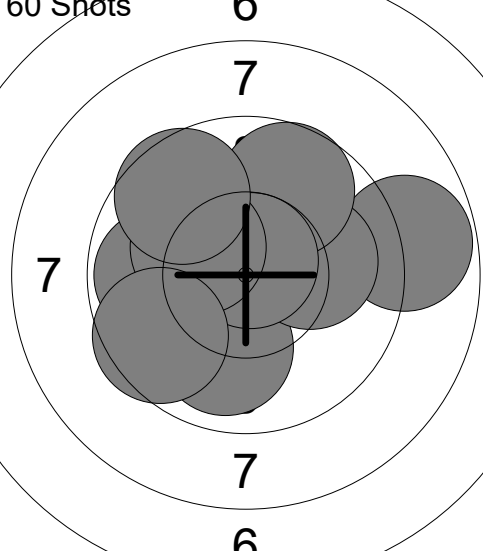
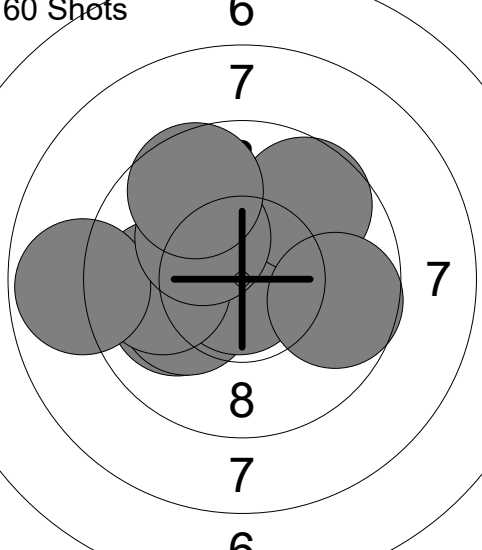
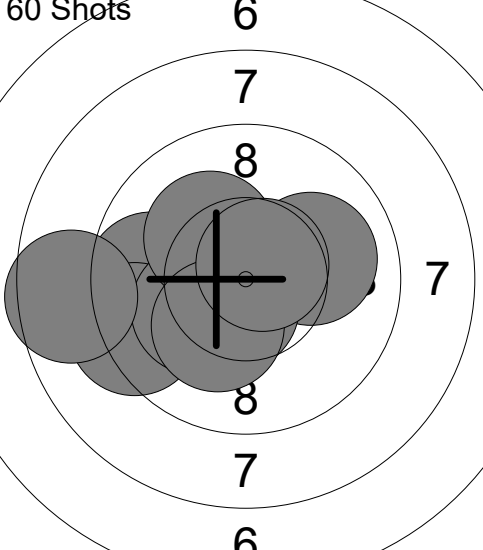
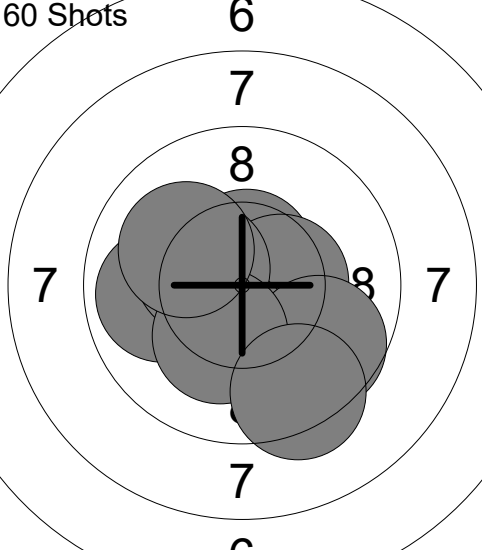
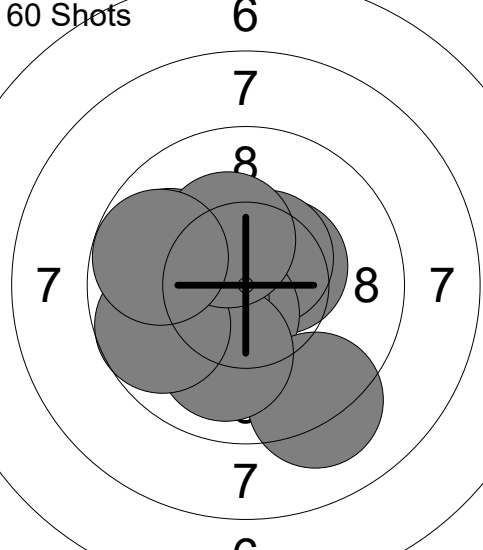
<p>60 Shots</p>  <p style="text-align: center;">6 7 8 7 7 7</p>	<p>1: 8.9 ↘ 2: 9.9 → 3: 9.8 ← 4: 10.7x ↑ 5: 9.3 → 6: 9.2 → 7: 9.6 ↓ 8: 10.5x ↗ 9: 10.6x ↓ 10: 10.6x ↓</p> <p>Series 99.1 99.1</p>	<p>60 Shots</p>  <p style="text-align: center;">6 7 7 7 7 7</p>	<p>11: 8.8 → 12: 10.0 ↓ 13: 10.2x ↗ 14: 10.1 → 15: 9.7 ↗ 16: 10.8x ↑ 17: 9.8 ← 18: 10.2x ↖ 19: 9.6 ↖ 20: 9.6 ↙</p> <p>Series 98.8 197.9</p>
<p>60 Shots</p>  <p style="text-align: center;">6 6 7 7 7 7</p>	<p>21: 10.0 ← 22: 10.1 ← 23: 10.5x → 24: 10.8x ↓ 25: 9.7 ↗ 26: 9.9 ← 27: 8.8 ← 28: 10.2x ↗ 29: 9.7 → 30: 9.6 ↗</p> <p>Series 99.3 297.2</p>	<p>60 Shots</p>  <p style="text-align: center;">6 6 7 7 7 7</p>	<p>31: 10.0 → 32: 9.7 ← 33: 10.6x ↓ 34: 10.6x ← 35: 9.3 ← 36: 10.2x ← 37: 10.2x ↖ 38: 8.6 ← 39: 10.2x ↓ 40: 10.7x ↗</p> <p>Series 100.1 397.3</p>
<p>60 Shots</p>  <p style="text-align: center;">6 6 7 7 7 7</p>	<p>41: 10.6x ↖ 42: 10.6x ↑ 43: 9.9 ← 44: 10.4x → 45: 10.3x ↓ 46: 10.4x ↖ 47: 9.7 ↘ 48: 10.2x ↓ 49: 9.4 ↓ 50: 10.1 ↖</p> <p>Series 101.6 498.9</p>	<p>60 Shots</p>  <p style="text-align: center;">6 6 7 7 7 7</p>	<p>51: 10.4x → 52: 10.5x ↗ 53: 10.5x ↓ 54: 9.2 ↓ 55: 10.3x ← 56: 9.9 ← 57: 10.0 ↓ 58: 9.7 ← 59: 10.3x ↗ 60: 9.8 ←</p> <p>Series 100.6 599.5</p>

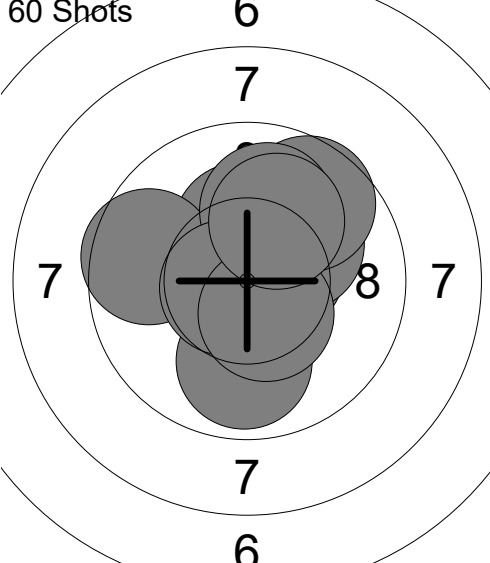
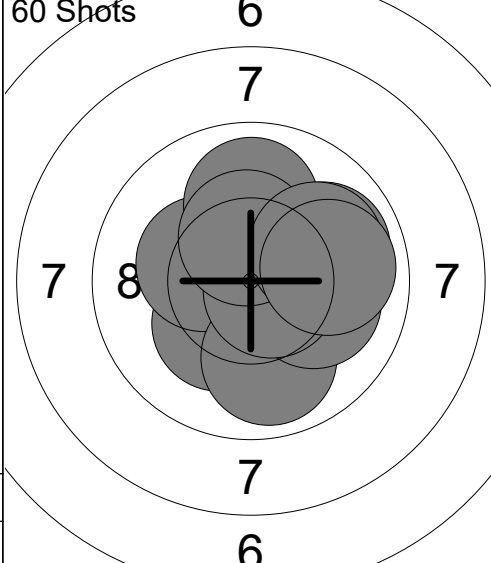
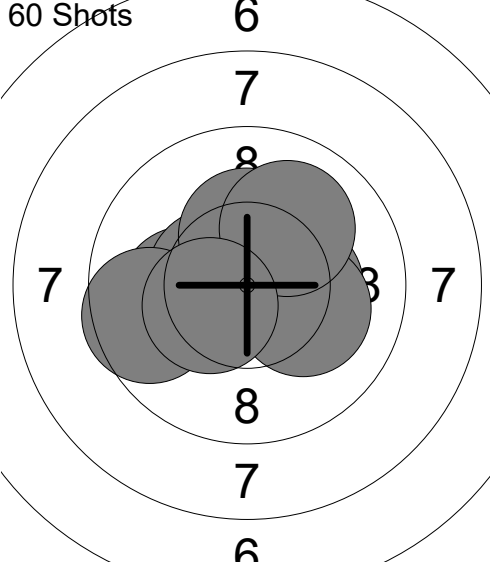
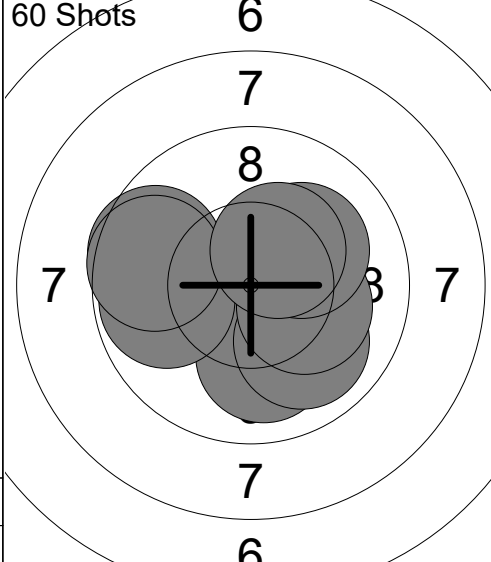
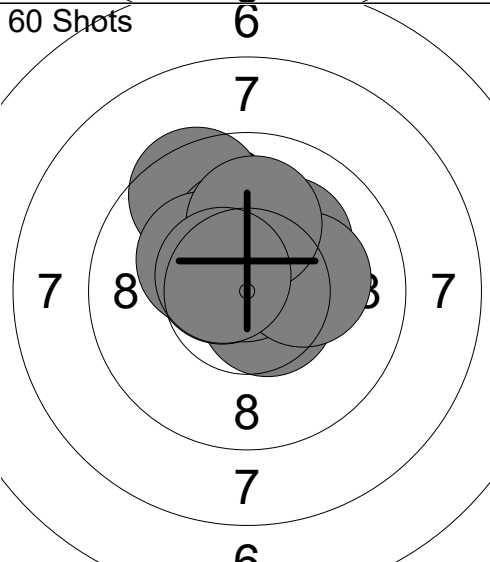
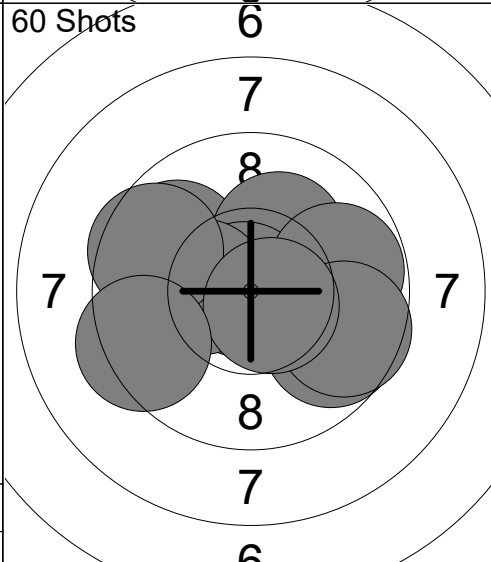
60 Shots 	1: 10.3x ↑ 2: 10.5x → 3: 10.1 → 4: 9.6 ← 5: 9.7 ↗ 6: 9.9 ↓ 7: 10.0 ↑ 8: 10.7x ← 9: 10.4x ↓ 10: 10.1 ↑ Series 101.3 101.3	60 Shots 	11: 10.3x ↓ 12: 10.3x ← 13: 9.9 → 14: 9.9 ↑ 15: 9.9 ↓ 16: 10.1 → 17: 10.7x → 18: 10.4x ↑ 19: 10.0 → 20: 9.9 → Series 101.4 202.7
60 Shots 	21: 10.6x ↑ 22: 10.1 ← 23: 10.5x ← 24: 10.8x → 25: 10.3x ↑ 26: 10.3x → 27: 10.2x → 28: 10.0 ↗ 29: 9.6 ← 30: 10.4x ← Series 102.8 305.5	60 Shots 	31: 10.8x → 32: 10.5x → 33: 10.0 ↓ 34: 10.0 ↓ 35: 9.6 ← 36: 9.8 ← 37: 10.2x → 38: 9.6 ← 39: 10.1 → 40: 10.4x ↗ Series 101.0 406.5
60 Shots 	41: 9.5 ↗ 42: 10.6x ↓ 43: 10.6x ← 44: 10.2x ↗ 45: 10.2x ↑ 46: 10.7x ↑ 47: 10.2x ← 48: 10.2x → 49: 10.1 ↑ 50: 10.6x ← Series 102.9 509.4	60 Shots 	51: 9.8 ← 52: 10.2x ↗ 53: 10.9x ← 54: 9.7 → 55: 9.8 → 56: 9.6 → 57: 10.3x ← 58: 9.6 ← 59: 10.6x ↓ 60: 9.4 ← Series 99.9 609.3

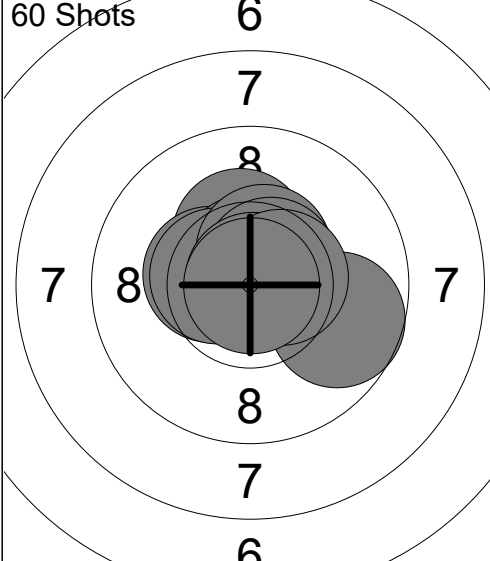
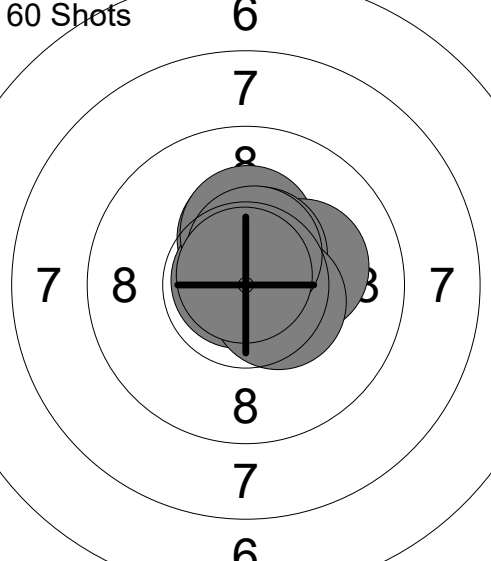
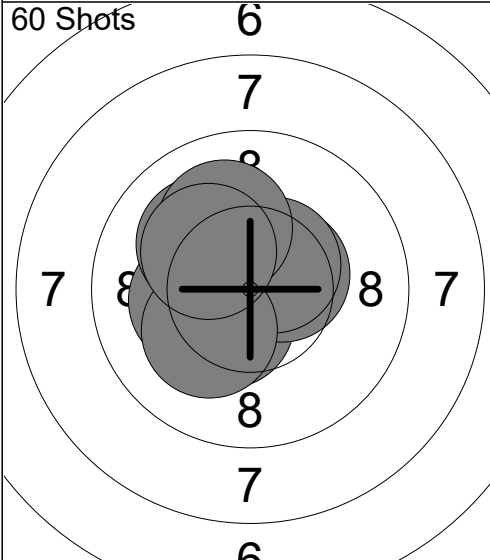
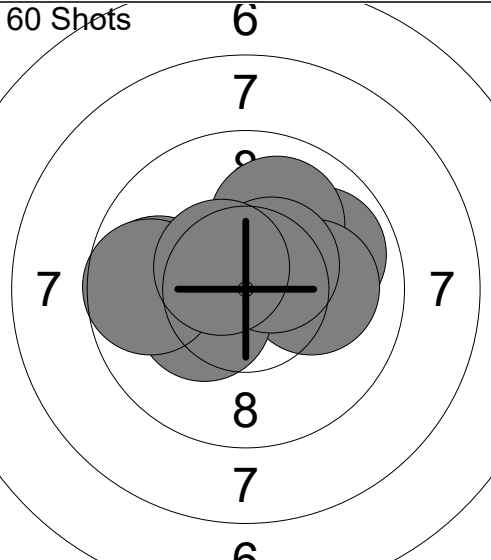
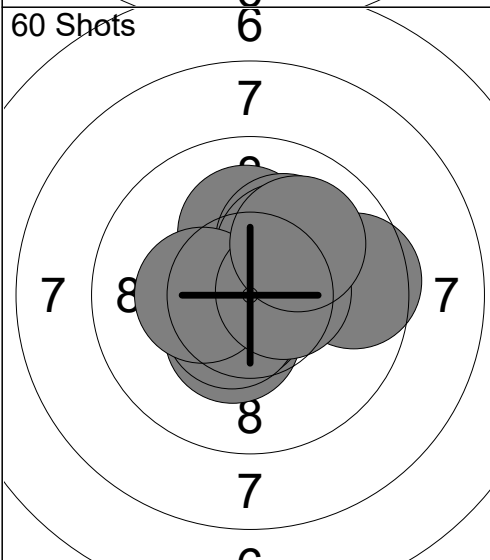
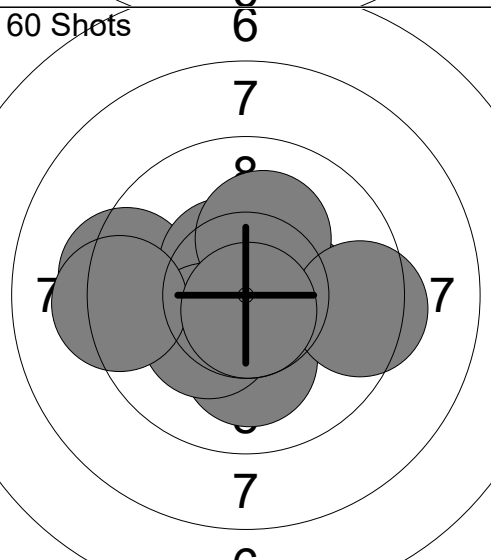
60 Shots 	1: 10.3x ↑ 2: 10.4x ← 3: 10.6x ↑ 4: 9.7 → 5: 10.5x ← 6: 10.5x ↑ 7: 10.6x ↗ 8: 10.9x ↗ 9: 10.5x → 10: 10.9x ⇒ Series 104.9 104.9	60 Shots 	11: 10.3x ↑ 12: 10.7x ↗ 13: 10.8x ↗ 14: 10.8x ← 15: 10.3x ↑ 16: 10.2x → 17: 10.5x ↗ 18: 10.5x ⇒ 19: 10.5x ↑ 20: 10.8x ↑ Series 105.4 210.3
60 Shots 	21: 10.4x ↘ 22: 10.4x ↘ 23: 10.5x → 24: 10.5x ↑ 25: 10.5x ↗ 26: 10.2x ← 27: 10.2x ↘ 28: 10.1 ↘ 29: 10.1 ↑ 30: 10.2x ↘ Series 103.1 313.4	60 Shots 	31: 10.7x ↑ 32: 10.8x ↘ 33: 9.9 → 34: 10.0 ↗ 35: 9.8 ← 36: 10.1 → 37: 10.3x ↘ 38: 10.5x ↗ 39: 9.7 ← 40: 10.5x ↘ Series 102.3 415.7
60 Shots 	41: 10.1 ↑ 42: 9.6 → 43: 10.1 ↗ 44: 10.4x ↘ 45: 10.2x ↗ 46: 10.7x ↘ 47: 10.5x ↘ 48: 10.3x ← 49: 10.5x → 50: 10.0 ↗ Series 102.4 518.1	60 Shots 	51: 9.3 ← 52: 10.3x → 53: 10.5x ↘ 54: 10.5x ↘ 55: 10.1 ↓ 56: 10.3x ↘ 57: 10.2x ↑ 58: 9.4 → 59: 9.3 ← 60: 10.7x ↓ Series 100.6 618.7

<p>60 Shots</p>	<p>1: 9.9 ← 2: 10.7x ↓ 3: 9.5 ↑ 4: 9.5 → 5: 10.8x ↗ 6: 10.1 ↑ 7: 10.2x → 8: 10.0 ↗ 9: 9.8 ↑ 10: 10.4x ←</p> <p>Series 100.9</p> <p style="text-align: center;">100.9</p>	<p>60 Shots</p>	<p>11: 9.0 ↗ 12: 9.7 ← 13: 10.6x ↓ 14: 9.3 ↗ 15: 9.3 ← 16: 9.8 ↑ 17: 9.3 ↓ 18: 9.9 ↓ 19: 10.9x ← 20: 9.9 ↑</p> <p>Series 97.7</p> <p style="text-align: center;">198.6</p>
<p>60 Shots</p>	<p>21: 10.4x → 22: 9.2 ↑ 23: 9.3 ↑ 24: 10.2x → 25: 8.9 ↓ 26: 9.9 → 27: 9.6 ↓ 28: 10.6x ↑ 29: 10.0 ← 30: 10.1 ↓</p> <p>Series 98.2</p> <p style="text-align: center;">296.8</p>	<p>60 Shots</p>	<p>31: 9.4 ↓ 32: 9.9 ↓ 33: 8.9 → 34: 10.4x ↗ 35: 10.6x ← 36: 10.3x ↗ 37: 10.3x ↑ 38: 10.6x ↗ 39: 10.3x ↓ 40: 10.5x →</p> <p>Series 101.2</p> <p style="text-align: center;">398.0</p>
<p>60 Shots</p>	<p>41: 9.4 ← 42: 10.2x ↓ 43: 10.5x ↓ 44: 10.0 ← 45: 9.8 ↓ 46: 9.8 ↗ 47: 9.1 ↑ 48: 9.2 ↗ 49: 10.0 ↑ 50: 9.7 →</p> <p>Series 97.7</p> <p style="text-align: center;">495.7</p>	<p>60 Shots</p>	<p>51: 9.6 ↗ 52: 10.0 ↓ 53: 9.4 ← 54: 10.1 ← 55: 9.8 ↗ 56: 9.2 ← 57: 9.8 ↗ 58: 10.0 ↓ 59: 9.6 → 60: 10.4x ↗</p> <p>Series 97.9</p> <p style="text-align: center;">593.6</p>

<p>60 Shots</p>	<p>1: 10.0 ←</p> <p>2: 9.7 →</p> <p>3: 10.6x ↙</p> <p>4: 10.8x ↗</p> <p>5: 10.5x ↓</p> <p>6: 10.2x →</p> <p>7: 10.6x →</p> <p>8: 10.7x ↑</p> <p>9: 10.4x ←</p> <p>10: 9.6 ↓</p> <hr/> <p>Series 103.1</p> <hr/> <p>103.1</p>	<p>60 Shots</p>	<p>11: 9.5 ↖</p> <p>12: 10.3x →</p> <p>13: 10.7x ←</p> <p>14: 10.3x ↙</p> <p>15: 8.6 ↓</p> <p>16: 10.4x ↓</p> <p>17: 10.1 ↗</p> <p>18: 9.7 ↖</p> <p>19: 10.4x ↑</p> <p>20: 10.3x →</p> <hr/> <p>Series 100.3</p> <hr/> <p>203.4</p>
<p>60 Shots</p>	<p>21: 9.4 ←</p> <p>22: 10.3x →</p> <p>23: 10.7x →</p> <p>24: 10.1 ↓</p> <p>25: 9.8 ←</p> <p>26: 10.7x ↓</p> <p>27: 10.4x ↖</p> <p>28: 10.3x ↓</p> <p>29: 10.1 ↗</p> <p>30: 9.8 ↓</p> <hr/> <p>Series 101.6</p> <hr/> <p>305.0</p>	<p>60 Shots</p>	<p>31: 9.6 →</p> <p>32: 10.7x ↙</p> <p>33: 10.6x ↖</p> <p>34: 9.9 →</p> <p>35: 10.0 ↓</p> <p>36: 10.6x ↑</p> <p>37: 10.7x ↗</p> <p>38: 10.0 ↓</p> <p>39: 9.7 ↖</p> <p>40: 9.8 ↓</p> <hr/> <p>Series 101.6</p> <hr/> <p>406.6</p>
<p>60 Shots</p>	<p>41: 10.5x →</p> <p>42: 10.8x ↓</p> <p>43: 10.4x ↓</p> <p>44: 10.1 ←</p> <p>45: 10.5x →</p> <p>46: 10.3x ↙</p> <p>47: 10.7x →</p> <p>48: 9.7 ↓</p> <p>49: 10.1 ↓</p> <p>50: 10.3x ↙</p> <hr/> <p>Series 103.4</p> <hr/> <p>510.0</p>	<p>60 Shots</p>	<p>51: 10.4x ↗</p> <p>52: 10.7x ↙</p> <p>53: 10.6x ↓</p> <p>54: 9.0 ↖</p> <p>55: 10.3x ↗</p> <p>56: 9.9 ↓</p> <p>57: 10.1 ↖</p> <p>58: 9.8 →</p> <p>59: 10.4x ↗</p> <p>60: 9.6 →</p> <hr/> <p>Series 100.8</p> <hr/> <p>610.8</p>

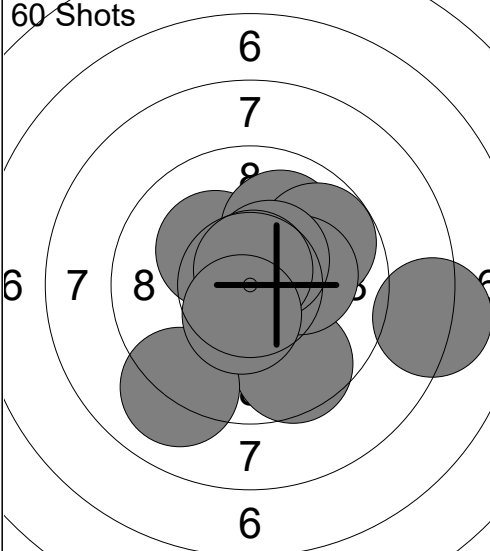
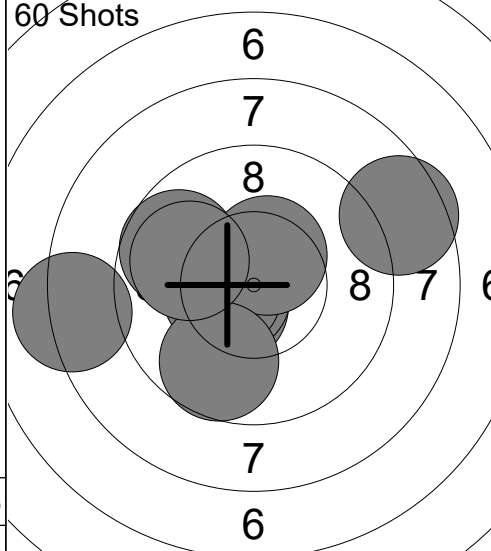
<p>60 Shots</p> 	<p>1: 9.6 ↘ 2: 8.2 → 3: 10.2x ↗ 4: 10.0 ↗ 5: 9.8 ↗ 6: 10.2x → 7: 9.1 ↘ 8: 10.5x ↗ 9: 10.7x ↗ 10: 10.5x ↘</p> <p>Series 98.8</p> <p style="text-align: center;">98.8</p>	<p>60 Shots</p> 	<p>11: 9.7 ↖ 12: 8.2 ← 13: 10.6x ↖ 14: 10.5x ↖ 15: 10.6x ← 16: 8.5 ↗ 17: 10.5x ← 18: 10.5x ↗ 19: 9.7 ↘ 20: 9.9 ↖</p> <p>Series 98.7</p> <p style="text-align: center;">197.5</p>
--	---	--	--

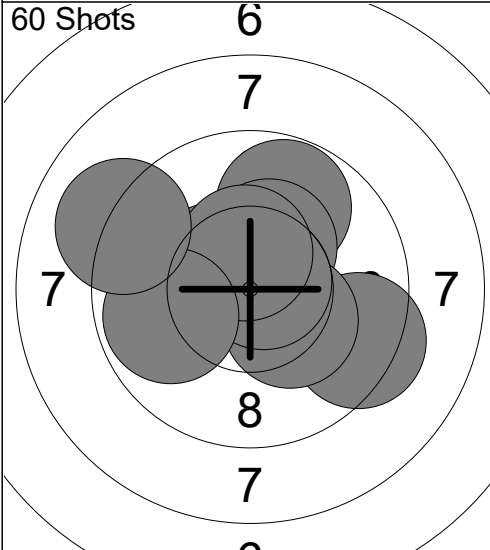
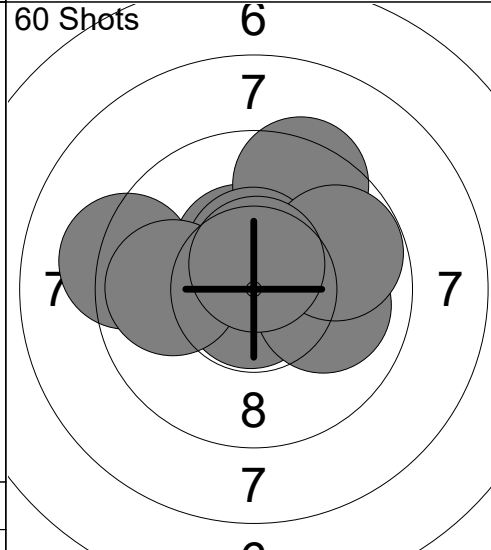
<p>60 Shots</p> 	<p>21: 9.8 ↗ 22: 10.4x ↖ 23: 9.4 → 24: 10.8x ↗ 25: 10.3x ↗ 26: 10.3x ↘ 27: 10.7x ↗ 28: 10.5x ↗ 29: 9.8 ← 30: 9.1 ↖</p> <p>Series 101.1</p> <p style="text-align: center;">298.6</p>	<p>60 Shots</p> 	<p>31: 10.4x ↗ 32: 10.8x ↘ 33: 10.1 → 34: 9.4 ↗ 35: 10.0 → 36: 10.5x ↗ 37: 9.2 ← 38: 9.9 ← 39: 9.8 → 40: 10.6x ↗</p> <p>Series 100.7</p> <p style="text-align: center;">399.3</p>
---	---	---	---

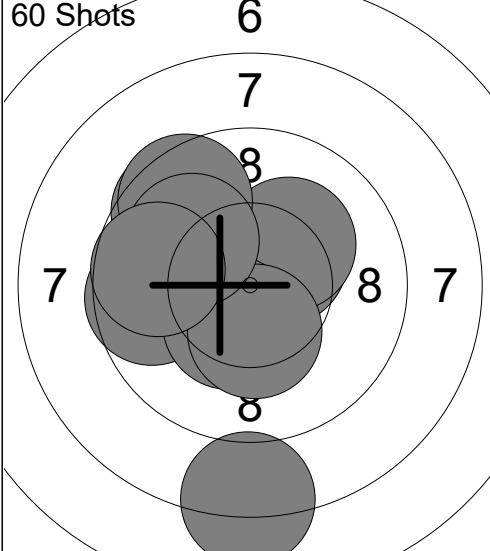
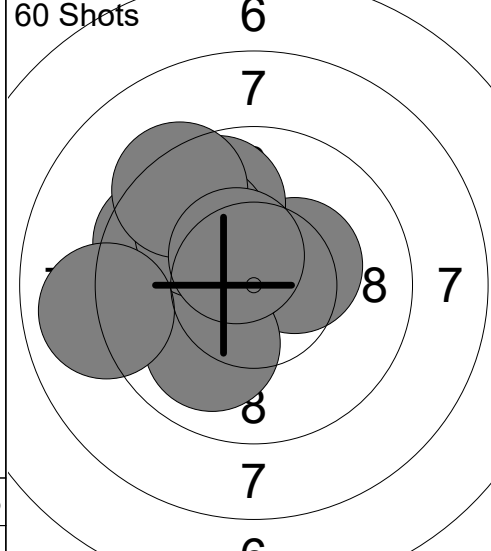
<p>60 Shots</p> 	<p>41: 10.4x ↗ 42: 9.6 ↖ 43: 10.2x ↗ 44: 9.6 ← 45: 9.5 ↗ 46: 10.4x ↘ 47: 8.1 ↘ 48: 10.3x ↘ 49: 10.0 ↖ 50: 9.7 ←</p> <p>Series 97.8</p> <p style="text-align: center;">497.1</p>	<p>60 Shots</p> 	<p>51: 10.3x ↗ 52: 10.5x ↖ 53: 9.8 ↗ 54: 9.6 ↖ 55: 10.3x ← 56: 10.0 ↘ 57: 10.0 ↖ 58: 9.4 ↗ 59: 9.0 ← 60: 10.5x ↗</p> <p>Series 99.4</p> <p style="text-align: center;">596.5</p>
--	---	--	--

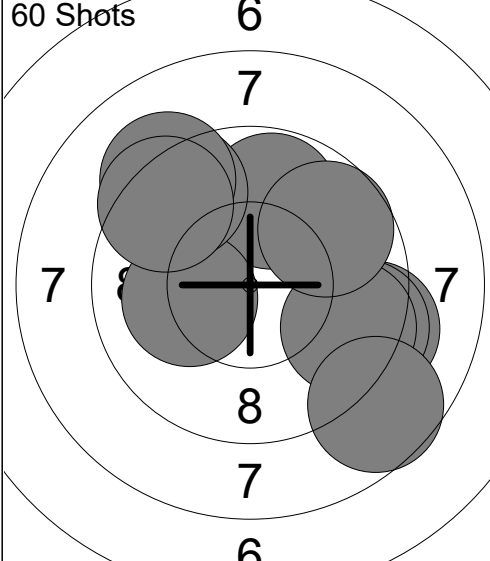
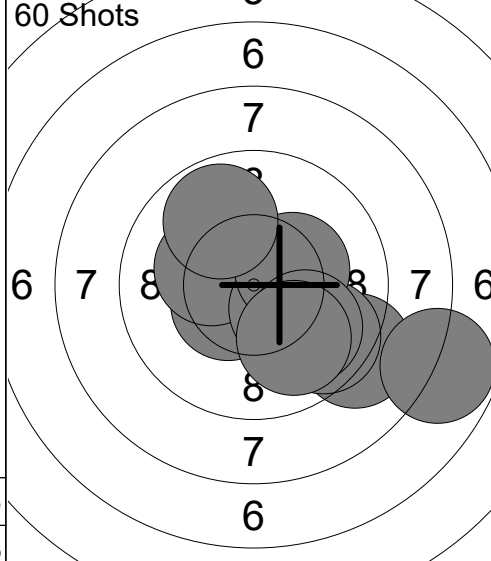
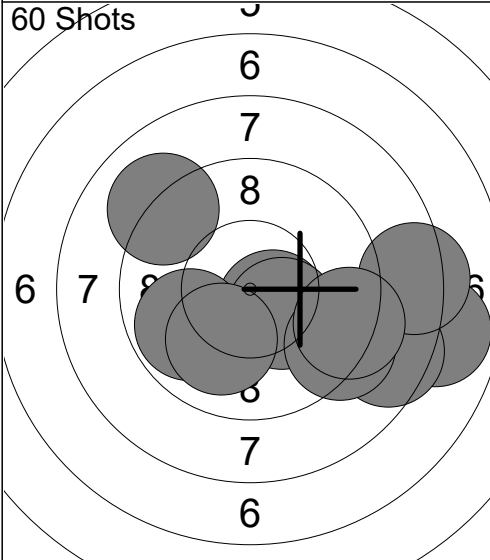
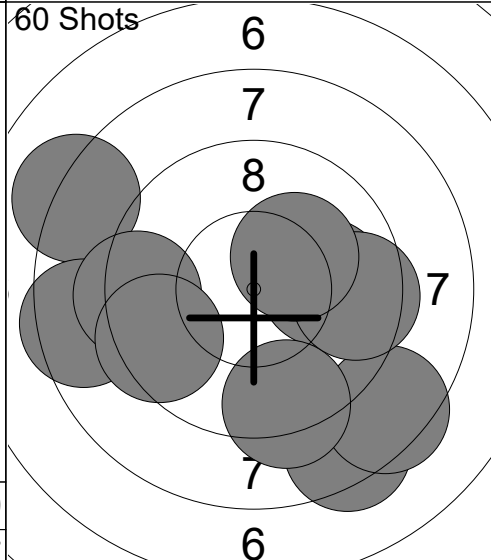
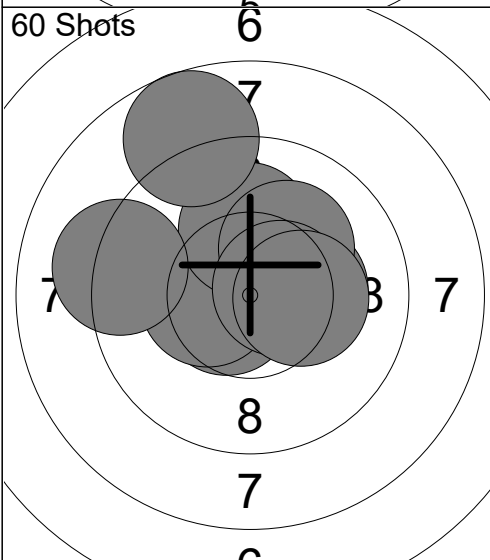
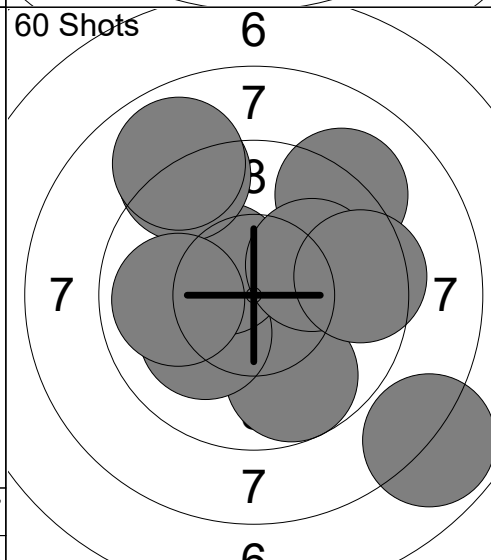
<p>60 Shots</p> 	<p>1: 9.8 ↑</p> <p>2: 10.1 ←</p> <p>3: 9.4 ↗</p> <p>4: 9.2 ↘</p> <p>5: 9.4 ↘</p> <p>6: 9.2 ↗</p> <p>7: 9.5 ↘</p> <p>8: 9.7 ↗</p> <p>9: 9.4 ↗</p> <p>10: 8.6 ↘</p> <hr/> <p>Series 94.3</p> <p style="text-align: right;">94.3</p>	<p>60 Shots</p> 	<p>11: 10.5x ↙</p> <p>12: 10.2x ↖</p> <p>13: 9.1 ↘</p> <p>14: 10.3x ↘</p> <p>15: 7.8 ↘</p> <p>16: 9.6 ↘</p> <p>17: 10.3x →</p> <p>18: 9.8 ↗</p> <p>19: 9.9 ↘</p> <p>20: 9.9 ↘</p> <hr/> <p>Series 97.4</p> <p style="text-align: right;">191.7</p>
<p>60 Shots</p> 	<p>21: 7.9 →</p> <p>22: 8.5 ↘</p> <p>23: 8.3 →</p> <p>24: 10.5x ↘</p> <p>25: 9.8 ←</p> <p>26: 10.3x ↘</p> <p>27: 9.1 ↗</p> <p>28: 10.0 ↘</p> <p>29: 9.3 ↘</p> <p>30: 9.3 →</p> <hr/> <p>Series 93.0</p> <p style="text-align: right;">284.7</p>	<p>60 Shots</p> 	<p>31: 10.0 →</p> <p>32: 8.4 ↘</p> <p>33: 8.1 ↗</p> <p>34: 8.5 ←</p> <p>35: 8.4 ↘</p> <p>36: 9.3 ↘</p> <p>37: 9.3 ←</p> <p>38: 9.5 →</p> <p>39: 10.2x ↗</p> <p>40: 9.5 ←</p> <hr/> <p>Series 91.2</p> <p style="text-align: right;">375.9</p>
<p>60 Shots</p> 	<p>41: 10.3x →</p> <p>42: 10.4x ↑</p> <p>43: 10.6x ←</p> <p>44: 10.4x ←</p> <p>45: 10.1 ↑</p> <p>46: 8.7 ↑</p> <p>47: 10.2x ↗</p> <p>48: 9.2 ←</p> <p>49: 10.5x →</p> <p>50: 10.3x →</p> <hr/> <p>Series 100.7</p> <p style="text-align: right;">476.6</p>	<p>60 Shots</p> 	<p>51: 7.9 ↘</p> <p>52: 9.7 ↘</p> <p>53: 10.1 ←</p> <p>54: 10.4x ↗</p> <p>55: 9.1 ↗</p> <p>56: 8.9 ↗</p> <p>57: 9.9 ←</p> <p>58: 9.1 ↗</p> <p>59: 10.1 ↗</p> <p>60: 9.5 →</p> <hr/> <p>Series 94.7</p> <p style="text-align: right;">571.3</p>

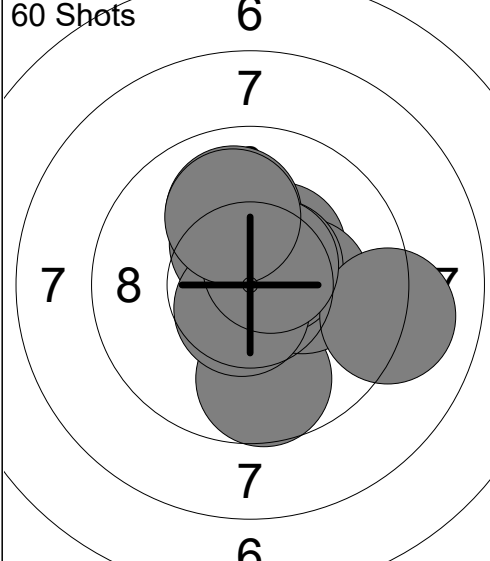
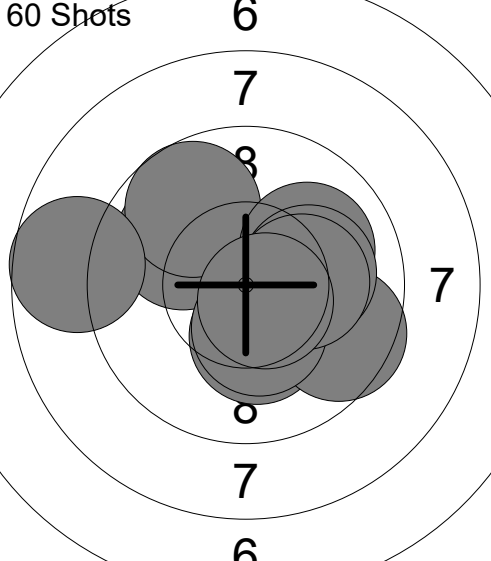
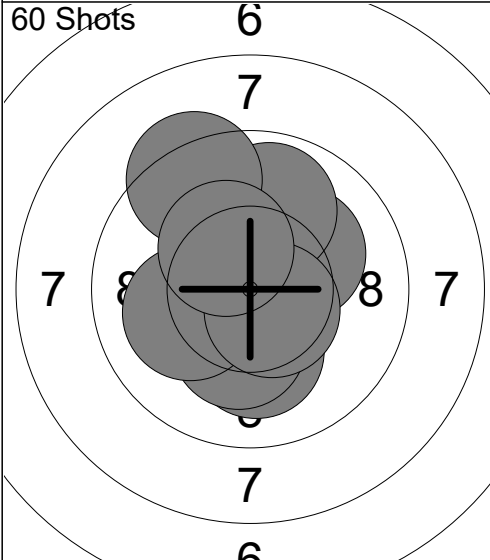
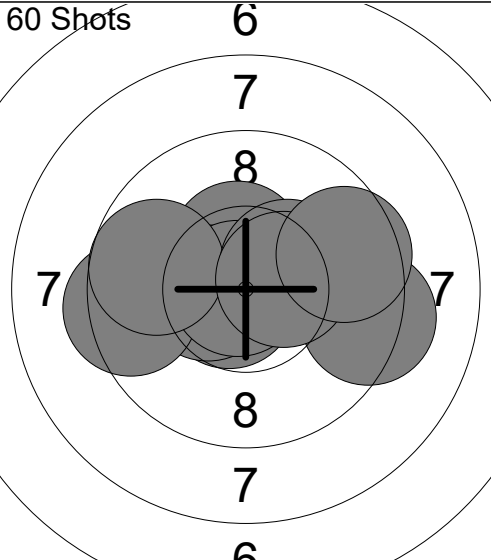
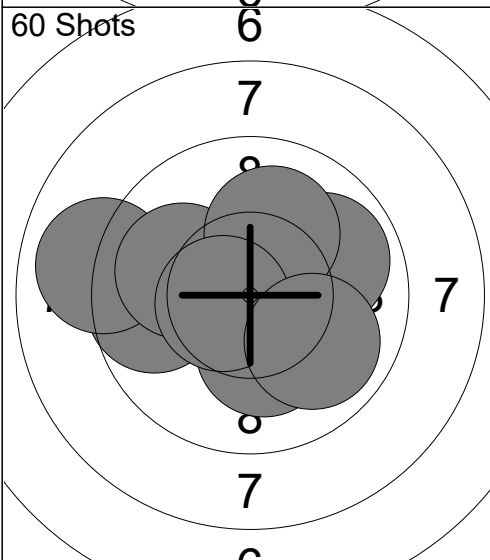
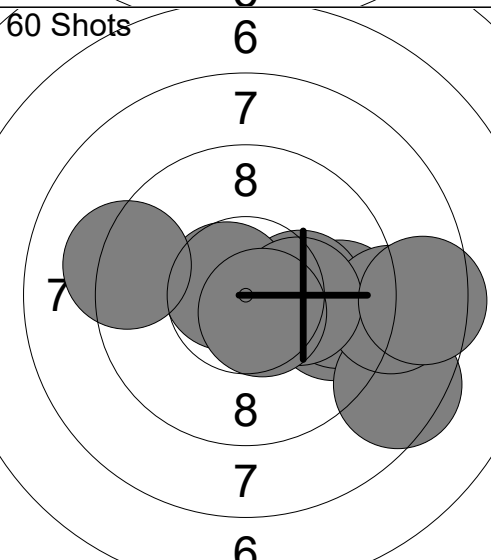
<p>60 Shots</p>  <p style="text-align: center;">6 7 7 8 7 7 7 8 7 7</p>	<p>1: 9.7 ↓ 2: 10.4x ↗ 3: 10.3x → 4: 10.4x ↑ 5: 10.5x ↗ 6: 10.6x ↓ 7: 10.0 ↑ 8: 9.1 → 9: 10.6x ↗ 10: 10.0 ↑</p> <p>Series 101.6</p>	<p>60 Shots</p>  <p style="text-align: center;">6 7 8 7 7 7 7 8 7 7</p>	<p>11: 10.3x ↓ 12: 9.9 ↗ 13: 9.7 ↗ 14: 9.6 → 15: 10.0 ↗ 16: 10.4x ↓ 17: 10.1 → 18: 8.7 ← 19: 10.2x → 20: 10.6x ↘</p> <p>Series 99.5</p>
	101.6		201.1
<p>60 Shots</p>  <p style="text-align: center;">6 7 7 8 7 7 7 8 7 7</p>	<p>21: 10.1 ↓ 22: 10.2x ↓ 23: 10.7x ↖ 24: 10.7x → 25: 10.2x ↗ 26: 9.9 ↑ 27: 10.1 ← 28: 9.3 ↗ 29: 10.5x ↘ 30: 10.3x ↗</p> <p>Series 102.0</p>	<p>60 Shots</p>  <p style="text-align: center;">6 7 8 7 7 7 7 8 7 7</p>	<p>31: 10.4x ↑ 32: 10.7x ↖ 33: 10.4x ↖ 34: 9.4 ← 35: 10.8x ↖ 36: 9.7 ← 37: 10.3x ↗ 38: 9.3 → 39: 10.4x → 40: 9.6 →</p> <p>Series 101.0</p>
	303.1		404.1
<p>60 Shots</p>  <p style="text-align: center;">6 7 8 7 7 7 7 8 7 7</p>	<p>41: 9.9 → 42: 9.7 ← 43: 10.6x ↖ 44: 9.0 ← 45: 10.0 ← 46: 10.2x ↓ 47: 10.9x ↓ 48: 10.1 ↑ 49: 10.6x ↖ 50: 9.9 ↘</p> <p>Series 100.9</p>	<p>60 Shots</p>  <p style="text-align: center;">6 7 8 7 7 7 7 8 7 7</p>	<p>51: 9.7 → 52: 9.6 → 53: 8.5 ↘ 54: 10.2x → 55: 10.7x ↖ 56: 8.9 → 57: 10.2x → 58: 9.2 ← 59: 10.6x ↘ 60: 8.5 →</p> <p>Series 96.1</p>
	505.0		601.1

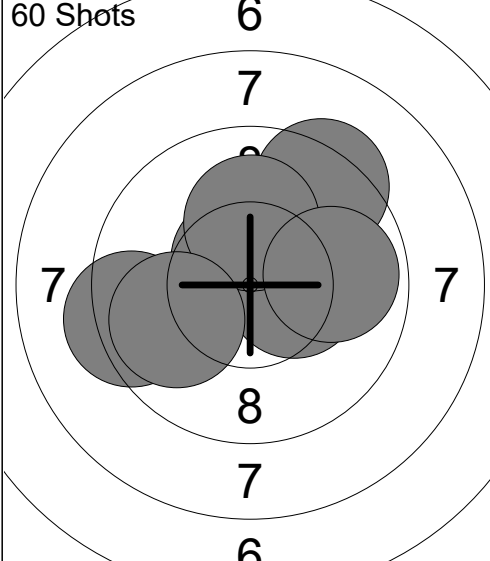
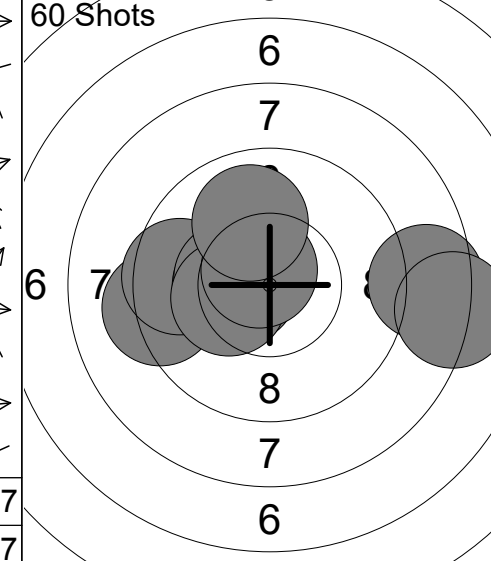
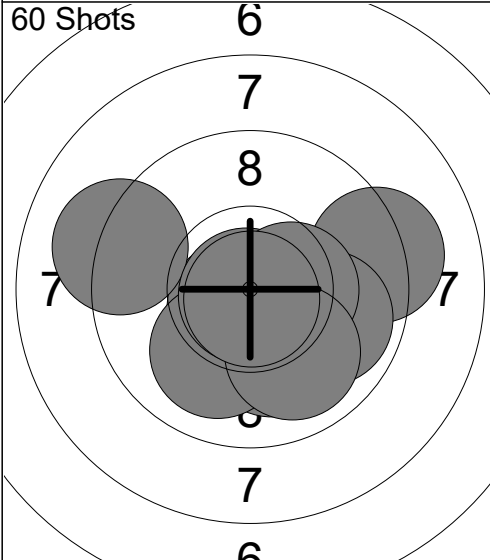
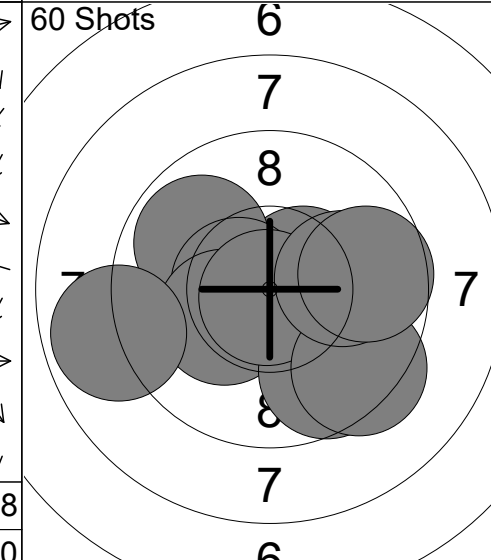
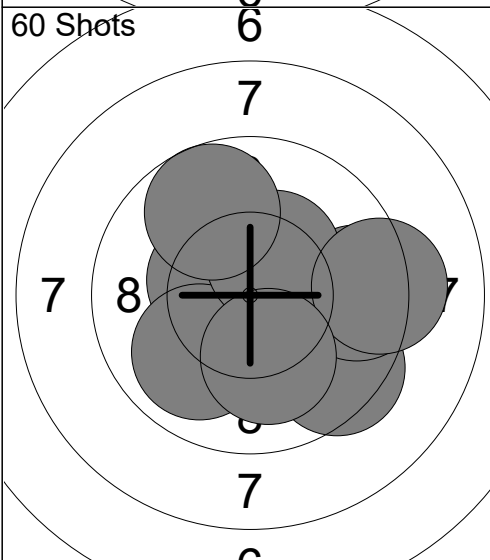
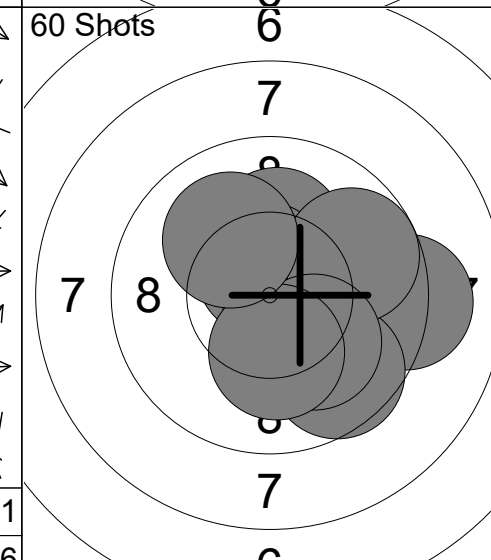
<p>60 Shots</p> 	<p>1: 10.3x →</p> <p>2: 9.3 ←</p> <p>3: 10.3x ↑</p> <p>4: 10.6x →</p> <p>5: 10.6x ↖</p> <p>6: 9.3 ↗</p> <p>7: 10.4x →</p> <p>8: 10.1 ↑</p> <p>9: 9.9 →</p> <p>10: 9.9 ←</p> <hr/> <p>Series 100.7</p> <hr/> <p>100.7</p>	<p>60 Shots</p> 	<p>11: 9.2 ←</p> <p>12: 9.6 ←</p> <p>13: 8.5 →</p> <p>14: 10.5x ←</p> <p>15: 10.3x ←</p> <p>16: 10.4x ←</p> <p>17: 10.3x ←</p> <p>18: 10.7x ↖</p> <p>19: 8.1 →</p> <p>20: 9.9 ↗</p> <hr/> <p>Series 97.5</p> <hr/> <p>198.2</p>
<p>60 Shots</p> 	<p>21: 9.2 →</p> <p>22: 10.1 ↓</p> <p>23: 10.6x ↓</p> <p>24: 10.0 ↓</p> <p>25: 9.9 →</p> <p>26: 9.1 ←</p> <p>27: 10.8x ↓</p> <p>28: 10.4x →</p> <p>29: 9.9 ↓</p> <p>30: 10.8x ↓</p> <hr/> <p>Series 100.8</p> <hr/> <p>299.0</p>	<p>60 Shots</p> 	<p>31: 10.5x ↗</p> <p>32: 9.9 ↖</p> <p>33: 10.5x ←</p> <p>34: 10.2x ←</p> <p>35: 9.6 ↓</p> <p>36: 10.8x ↓</p> <p>37: 9.4 ↓</p> <p>38: 10.0 →</p> <p>39: 8.9 ←</p> <p>40: 9.7 →</p> <hr/> <p>Series 99.5</p> <hr/> <p>398.5</p>
<p>60 Shots</p> 	<p>41: 10.1 →</p> <p>42: 10.3x ↓</p> <p>43: 10.4x ←</p> <p>44: 9.5 ↘</p> <p>45: 9.9 ↙</p> <p>46: 9.5 →</p> <p>47: 10.4x ↗</p> <p>48: 9.2 →</p> <p>49: 10.1 ↓</p> <p>50: 9.7 ↗</p> <hr/> <p>Series 99.1</p> <hr/> <p>497.6</p>	<p>60 Shots</p> 	<p>51: 10.5x →</p> <p>52: 10.2x ↑</p> <p>53: 10.6x ↑</p> <p>54: 9.2 →</p> <p>55: 10.6x ↘</p> <p>56: 9.6 ↘</p> <p>57: 9.7 ↗</p> <p>58: 10.1 ↘</p> <p>59: 10.2x ↓</p> <p>60: 10.1 ↗</p> <hr/> <p>Series 100.8</p> <hr/> <p>598.4</p>

<p>60 Shots</p> <p style="text-align: center;">4 5 6 7 8 7 6 5</p>	<p>1: 7.4 ↗ 2: 8.0 → 3: 7.0 → 4: 8.8 ↑ 5: 9.8 ↑ 6: 9.7 ↑ 7: 9.6 ← 8: 9.3 → 9: 9.8 → 10: 9.9 ↗</p> <p>Series 89.3</p>	<p>60 Shots</p> <p style="text-align: center;">6 7 8 7 6</p>	<p>11: 7.1 ↗ 12: 8.6 ↖ 13: 8.9 ↑ 14: 9.4 ↗ 15: 10.1 ↘ 16: 10.3x → 17: 8.6 ↖ 18: 10.0 ↘ 19: 10.6x ← 20: 10.1 ↘</p> <p>Series 93.7</p>
89.3		183.0	

<p>60 Shots</p> <p style="text-align: center;">6 7 7 7</p>	<p>21: 9.5 ↘ 22: 8.1 ↘ 23: 9.6 ↘ 24: 10.1 → 25: 9.9 ↗ 26: 10.1 ↗ 27: 10.3x ↘ 28: 10.0 ↗ 29: 9.5 ↖ 30: 9.6 ↑</p> <p>Series 96.7</p>	<p>60 Shots</p> <p style="text-align: center;">6 7 8 7</p>	<p>31: 9.9 ↘ 32: 10.4x ↗ 33: 10.6x ↖ 34: 8.7 → 35: 10.1 ↖ 36: 10.5x ↑ 37: 9.5 ↖ 38: 9.1 → 39: 9.9 → 40: 10.0 ↖</p> <p>Series 98.7</p>
279.7		378.4	

<p>60 Shots</p> <p style="text-align: center;">6 7 8 6 7 6</p>	<p>41: 9.2 ↖ 42: 8.9 → 43: 9.1 ↘ 44: 10.2x ↘ 45: 10.2x ↘ 46: 8.5 ↗ 47: 8.1 → 48: 10.1 ↘ 49: 9.7 → 50: 9.6 →</p> <p>Series 93.6</p>	<p>60 Shots</p> <p style="text-align: center;">6 7 8 7</p>	<p>51: 10.7x ↗ 52: 9.2 ↗ 53: 10.8x ↖ 54: 10.4x ↘ 55: 10.3x ↑ 56: 9.9 ← 57: 9.6 ↗ 58: 9.7 → 59: 10.5x → 60: 9.9 →</p> <p>Series 101.0</p>
472.0		573.0	

Relay 6	Lane 20	LEONARD Charlie
-------------------	-------------------	------------------------

1-80	Acorns Green	Precision	
------	--------------	-----------	--

31.01.2025	2025 AirNats by X Count	Civilian Marksmanship Program	
------------	-------------------------	-------------------------------	--

Comment	Signature		
---------	-----------	--	--

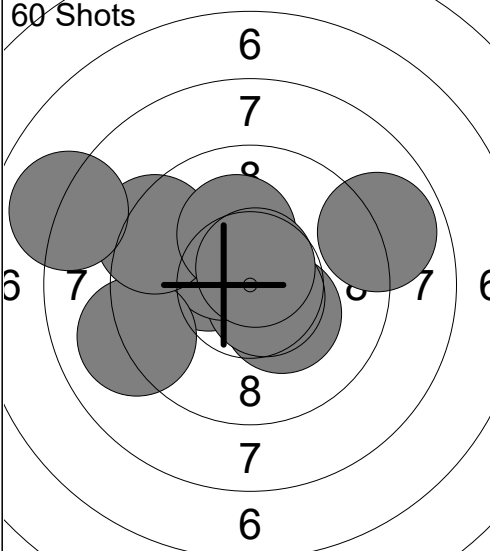
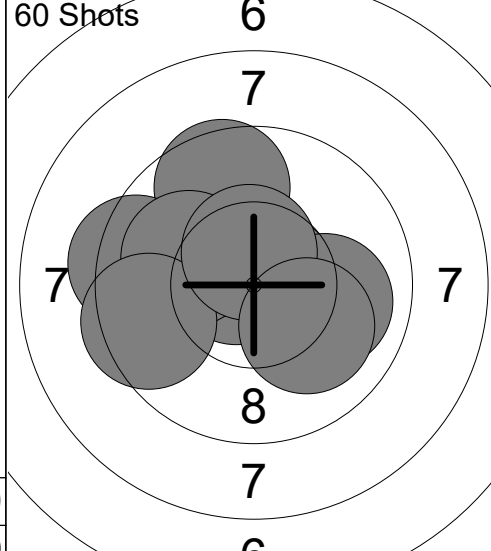
<p>60 Shots</p>  <p style="text-align: center;">6 7 8 7 6</p> <p style="text-align: center;">Series 97.9</p>	<p>1: 10.3x ↘ 2: 10.3x ← 3: 10.7x ↘ 4: 10.4x ↗ 5: 9.1 ← 6: 8.9 → 7: 9.3 ↖ 8: 8.0 ← 9: 10.2x ↑ 10: 10.7x ↑</p> <p style="text-align: center;">Series 97.9</p>	<p>60 Shots</p>  <p style="text-align: center;">6 7 8 7</p> <p style="text-align: center;">Series 100.6</p>	<p>11: 10.7x → 12: 10.0 → 13: 10.1 ↗ 14: 10.7x ↖ 15: 9.6 ↑ 16: 9.4 ← 17: 10.0 ↖ 18: 9.5 ← 19: 10.5x ↑ 20: 10.1 ↘</p> <p style="text-align: center;">Series 100.6</p>
97.9		198.5	

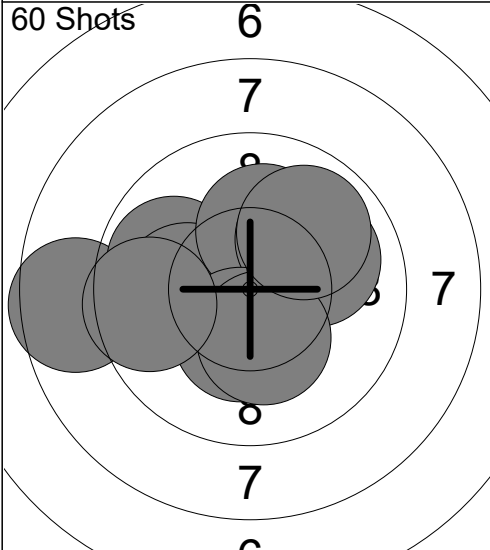
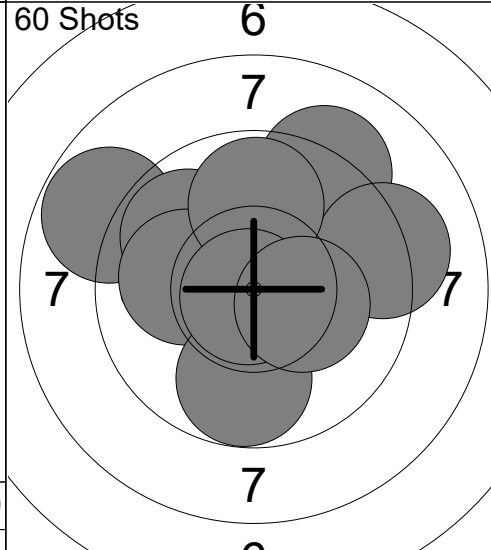
<p>60 Shots</p>  <p style="text-align: center;">6 7 8 7 6</p> <p style="text-align: center;">Series 98.9</p>	<p>21: 8.6 ← 22: 9.9 ← 23: 10.1 ← 24: 10.2x ↑ 25: 10.0 ↗ 26: 10.3x ↓ 27: 10.0 → 28: 10.3x ↓ 29: 9.6 ← 30: 9.9 ↗</p> <p style="text-align: center;">Series 98.9</p>	<p>60 Shots</p>  <p style="text-align: center;">6 7 7</p> <p style="text-align: center;">Series 98.1</p>	<p>31: 8.8 ← 32: 9.8 ↖ 33: 9.2 ↗ 34: 10.4x ← 35: 9.2 → 36: 10.0 ← 37: 9.8 ↑ 38: 9.8 ↓ 39: 10.8x ↖ 40: 10.3x →</p> <p style="text-align: center;">Series 98.1</p>
297.4		395.5	

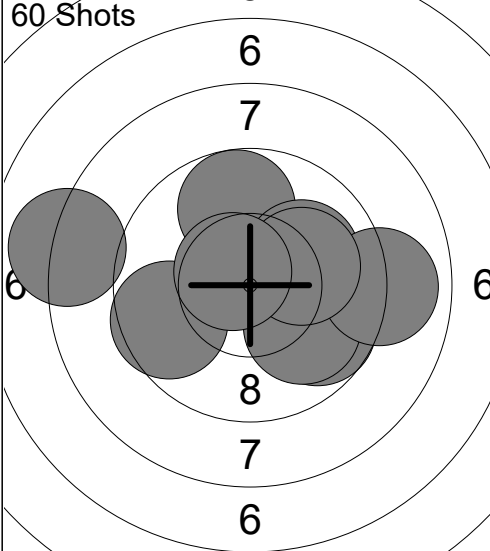
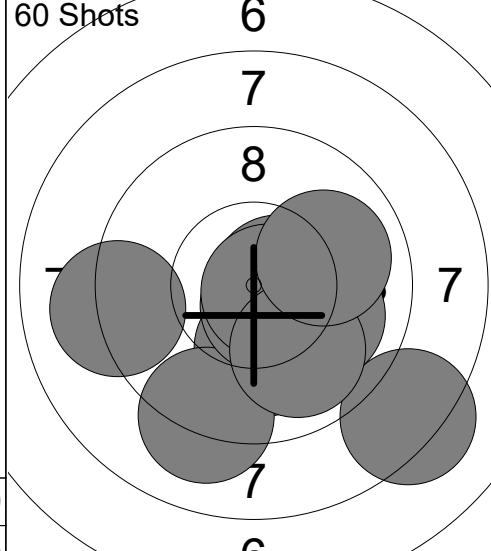
<p>60 Shots</p>  <p style="text-align: center;">6 7 8 7 6</p> <p style="text-align: center;">Series 97.0</p>	<p>41: 9.8 ↑ 42: 9.7 ↘ 43: 10.1 → 44: 10.1 → 45: 8.1 ← 46: 9.9 ↘ 47: 9.0 → 48: 9.6 ← 49: 10.1 → 50: 10.6x ↖</p> <p style="text-align: center;">Series 97.0</p>	<p>60 Shots</p>  <p style="text-align: center;">6 7 8 7 6</p> <p style="text-align: center;">Series 98.4</p>	<p>51: 8.3 ↘ 52: 10.1 ↓ 53: 9.1 ↓ 54: 10.6x → 55: 10.6x ↓ 56: 10.0 ↘ 57: 10.7x → 58: 9.1 ← 59: 9.9 ↓ 60: 10.0 →</p> <p style="text-align: center;">Series 98.4</p>
492.5		590.9	

Relay 6	Lane 21	JENKINS Hunter
-------------------	-------------------	-----------------------

1-80	MDJRC	Precision	
------	-------	-----------	--

31.01.2025	2025 AirNats by X Count	Civilian Marksmanship Program	
------------	-------------------------	-------------------------------	--

Comment	Signature		
---------	-----------	--	--

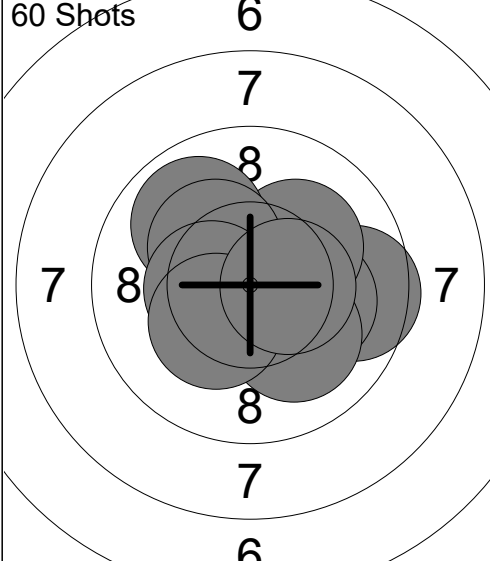
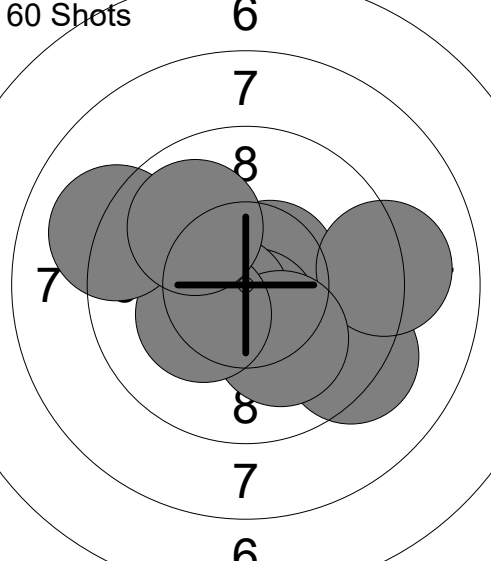
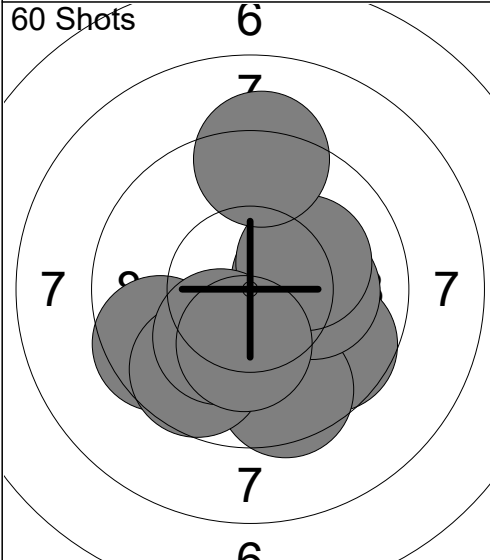
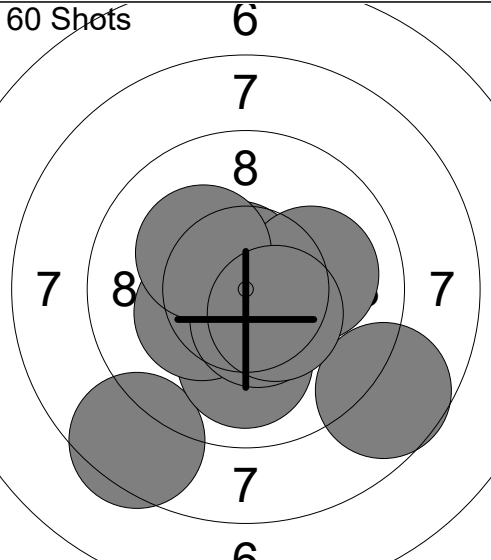
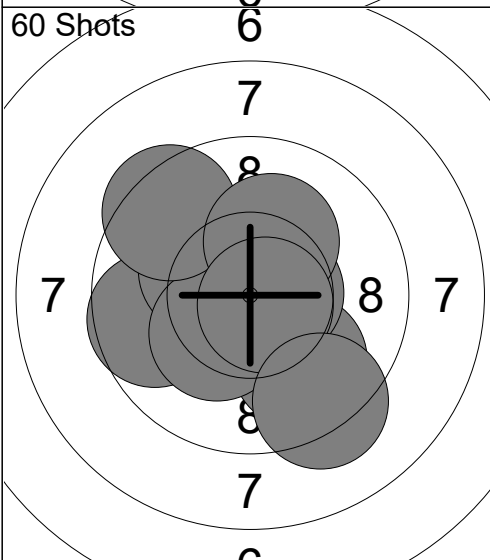
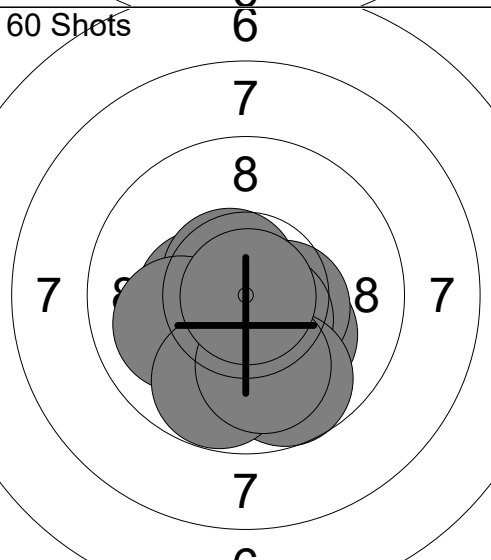
<p>60 Shots</p>  <p style="text-align: center;">6 7 8 7</p>	<p>1: 10.8x ↗</p> <p>2: 9.6 →</p> <p>3: 10.1 →</p> <p>4: 10.2x ↗</p> <p>5: 9.9 ↗</p> <p>6: 10.3x ↗</p> <p>7: 10.1 ↓</p> <p>8: 10.4x ←</p> <p>9: 10.3x ↙</p> <p>10: 10.5x →</p> <hr/> <p>Series 102.2</p> <p style="text-align: center;">102.2</p>	<p>60 Shots</p>  <p style="text-align: center;">6 7 8 7</p>	<p>11: 10.4x ←</p> <p>12: 9.3 ↘</p> <p>13: 10.6x ↗</p> <p>14: 10.5x ↓</p> <p>15: 10.6x ↙</p> <p>16: 9.1 →</p> <p>17: 10.1 ↓</p> <p>18: 10.3x ↙</p> <p>19: 9.1 ↖</p> <p>20: 9.9 ↗</p> <hr/> <p>Series 99.9</p> <p style="text-align: center;">202.1</p>
<p>60 Shots</p>  <p style="text-align: center;">6 7 7</p>	<p>21: 9.7 ↘</p> <p>22: 10.3x →</p> <p>23: 9.5 ↓</p> <p>24: 10.1 →</p> <p>25: 10.2x ↗</p> <p>26: 9.6 ←</p> <p>27: 9.7 ↙</p> <p>28: 9.2 ↑</p> <p>29: 10.2x ↙</p> <p>30: 10.2x ↓</p> <hr/> <p>Series 98.7</p> <p style="text-align: center;">300.8</p>	<p>60 Shots</p>  <p style="text-align: center;">6 7 8 7</p>	<p>31: 8.7 ↘</p> <p>32: 10.7x ↙</p> <p>33: 8.5 ↙</p> <p>34: 10.6x ↗</p> <p>35: 10.0 ↓</p> <p>36: 10.3x ↙</p> <p>37: 10.5x ↓</p> <p>38: 10.1 →</p> <p>39: 10.2x ↖</p> <p>40: 10.4x ↘</p> <hr/> <p>Series 100.0</p> <p style="text-align: center;">400.8</p>
<p>60 Shots</p>  <p style="text-align: center;">6 7 8 7 6</p>	<p>41: 9.6 ←</p> <p>42: 10.3x ↖</p> <p>43: 10.8x →</p> <p>44: 9.9 ↘</p> <p>45: 10.6x →</p> <p>46: 10.3x ↙</p> <p>47: 9.4 ↗</p> <p>48: 10.2x ↗</p> <p>49: 10.7x ↘</p> <p>50: 9.3 ↘</p> <hr/> <p>Series 101.1</p> <p style="text-align: center;">501.9</p>	<p>60 Shots</p>  <p style="text-align: center;">6 7 8 7 6</p>	<p>51: 10.2x ↘</p> <p>52: 10.4x ←</p> <p>53: 10.4x →</p> <p>54: 10.6x ↗</p> <p>55: 10.0 ←</p> <p>56: 10.5x ↓</p> <p>57: 9.7 ↓</p> <p>58: 9.8 ↓</p> <p>59: 10.0 ↓</p> <p>60: 10.9x ↘</p> <hr/> <p>Series 102.5</p> <p style="text-align: center;">604.4</p>

<p>60 Shots</p> <p style="text-align: center;">6</p>	<p>1: 10.0 ↗</p> <p>2: 10.3x ←</p> <p>3: 9.4 ↖</p> <p>4: 10.3x ←</p> <p>5: 9.6 ↓</p> <p>6: 10.4x ↑</p> <p>7: 9.8 ←</p> <p>8: 9.4 →</p> <p>9: 10.1 ↘</p> <p>10: 9.7 →</p> <hr/> <p>Series 99.0</p> <p style="text-align: center;">99.0</p>	<p>60 Shots</p> <p style="text-align: center;">6</p>	<p>11: 9.8 ↖</p> <p>12: 10.4x →</p> <p>13: 10.1 ↓</p> <p>14: 10.8x ←</p> <p>15: 10.3x ↙</p> <p>16: 10.7x →</p> <p>17: 10.4x ↗</p> <p>18: 10.0 →</p> <p>19: 10.3x ↗</p> <p>20: 10.4x ←</p> <hr/> <p>Series 103.2</p> <p style="text-align: center;">202.2</p>
<p>60 Shots</p> <p style="text-align: center;">6</p>	<p>21: 10.0 ↘</p> <p>22: 9.2 ↓</p> <p>23: 10.4x →</p> <p>24: 10.2x ↓</p> <p>25: 10.0 ↑</p> <p>26: 9.2 →</p> <p>27: 10.5x ←</p> <p>28: 10.5x ↘</p> <p>29: 10.3x →</p> <p>30: 10.7x ↗</p> <hr/> <p>Series 101.0</p> <p style="text-align: center;">303.2</p>	<p>60 Shots</p> <p style="text-align: center;">6</p>	<p>31: 10.0 →</p> <p>32: 10.3x ←</p> <p>33: 10.4x →</p> <p>34: 9.9 →</p> <p>35: 10.7x ↙</p> <p>36: 10.4x →</p> <p>37: 10.6x ↗</p> <p>38: 9.9 ←</p> <p>39: 10.6x ↗</p> <p>40: 10.1 ↓</p> <hr/> <p>Series 102.9</p> <p style="text-align: center;">406.1</p>
<p>60 Shots</p> <p style="text-align: center;">6</p>	<p>41: 10.7x →</p> <p>42: 10.3x ↘</p> <p>43: 10.6x →</p> <p>44: 10.5x ↗</p> <p>45: 10.4x →</p> <p>46: 10.5x ←</p> <p>47: 10.7x ↖</p> <p>48: 10.4x ↘</p> <p>49: 10.7x ↘</p> <p>50: 10.6x →</p> <hr/> <p>Series 105.4</p> <p style="text-align: center;">511.5</p>	<p>60 Shots</p> <p style="text-align: center;">6</p>	<p>51: 9.9 ↘</p> <p>52: 10.7x ↘</p> <p>53: 9.8 ↓</p> <p>54: 10.7x ↑</p> <p>55: 10.1 ←</p> <p>56: 9.8 ←</p> <p>57: 10.7x ↑</p> <p>58: 9.4 →</p> <p>59: 10.2x →</p> <p>60: 10.4x ↓</p> <hr/> <p>Series 101.7</p> <p style="text-align: center;">613.2</p>

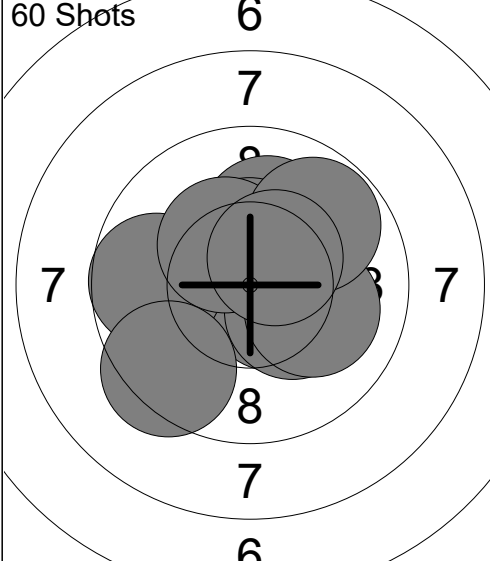
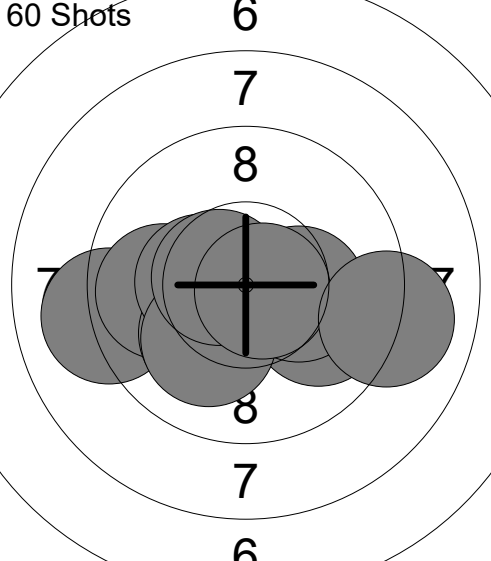
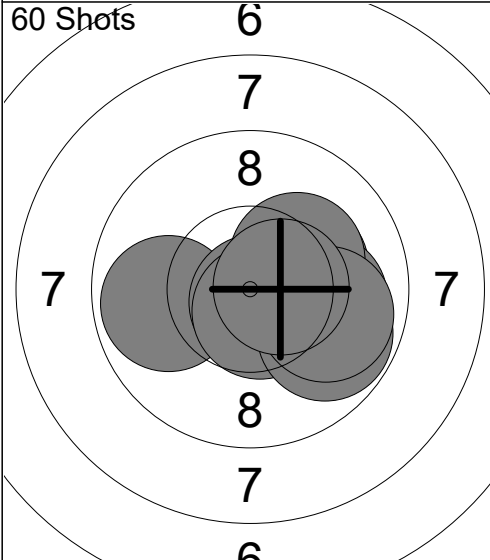
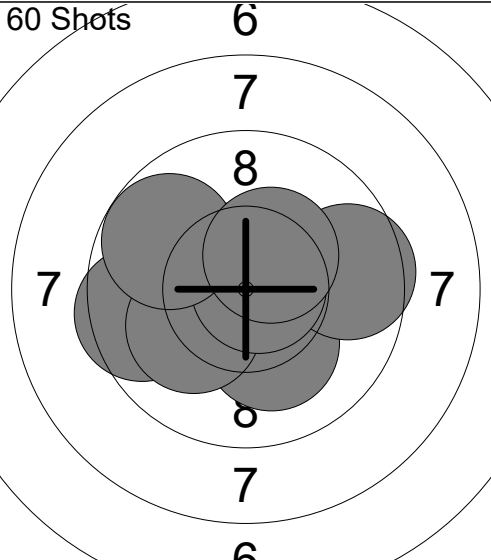
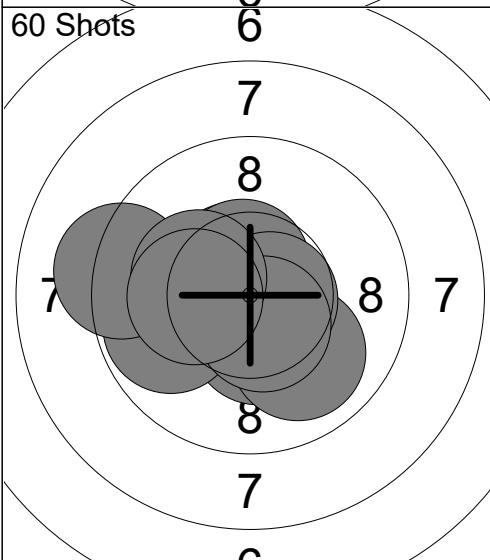
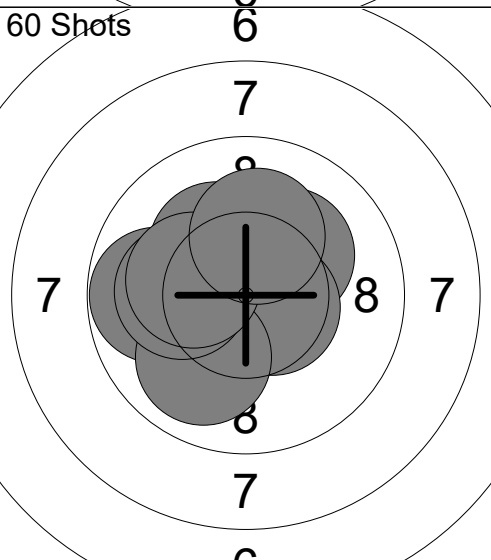
<p>60 Shots</p>  <p style="text-align: center;">6 7 8 7</p> <p style="text-align: center;">Series 101.2</p>	<p>1: 10.1 ↑</p> <p>2: 10.6x ↘</p> <p>3: 10.3x ↘</p> <p>4: 10.4x ↑</p> <p>5: 10.1 →</p> <p>6: 9.7 ←</p> <p>7: 10.3x ↗</p> <p>8: 9.8 ↗</p> <p>9: 9.4 ↙</p> <p>10: 10.5x ↗</p> <hr/> <p>Series 101.2</p>	<p>60 Shots</p>  <p style="text-align: center;">6 7 8 7</p> <p style="text-align: center;">Series 100.0</p>	<p>11: 9.1 ←</p> <p>12: 9.9 →</p> <p>13: 9.9 ←</p> <p>14: 10.1 ↙</p> <p>15: 10.2x →</p> <p>16: 10.4x ←</p> <p>17: 10.1 ↙</p> <p>18: 10.6x ←</p> <p>19: 10.7x →</p> <p>20: 9.0 →</p> <hr/> <p>Series 201.2</p>
<p>60 Shots</p>  <p style="text-align: center;">6 7 8 7</p> <p style="text-align: center;">Series 102.1</p>	<p>21: 10.3x →</p> <p>22: 10.2x →</p> <p>23: 9.8 ←</p> <p>24: 10.8x ↘</p> <p>25: 10.6x ↘</p> <p>26: 9.8 →</p> <p>27: 10.0 →</p> <p>28: 10.2x ↗</p> <p>29: 9.9 →</p> <p>30: 10.5x →</p> <hr/> <p>Series 303.3</p>	<p>60 Shots</p>  <p style="text-align: center;">6 7 8 7</p> <p style="text-align: center;">Series 101.8</p>	<p>31: 10.5x ←</p> <p>32: 10.2x ↘</p> <p>33: 9.5 ←</p> <p>34: 10.3x ←</p> <p>35: 9.6 →</p> <p>36: 10.6x ↖</p> <p>37: 10.1 ←</p> <p>38: 10.8x →</p> <p>39: 9.8 ↖</p> <p>40: 10.4x ↗</p> <hr/> <p>Series 405.1</p>
<p>60 Shots</p>  <p style="text-align: center;">6 7 8 7 6</p> <p style="text-align: center;">Series 102.2</p>	<p>41: 10.6x ↗</p> <p>42: 10.4x ↘</p> <p>43: 10.6x ↑</p> <p>44: 9.8 ←</p> <p>45: 9.2 ←</p> <p>46: 10.0 ↘</p> <p>47: 10.7x →</p> <p>48: 10.5x ↘</p> <p>49: 10.2x ←</p> <p>50: 10.2x ←</p> <hr/> <p>Series 507.3</p>	<p>60 Shots</p>  <p style="text-align: center;">6 7 8 7 6</p> <p style="text-align: center;">Series 102.7</p>	<p>51: 10.2x ↗</p> <p>52: 10.7x ↗</p> <p>53: 10.7x ↘</p> <p>54: 10.6x →</p> <p>55: 9.8 ←</p> <p>56: 10.2x ↗</p> <p>57: 10.0 ↙</p> <p>58: 10.1 ←</p> <p>59: 10.2x ←</p> <p>60: 10.2x ↑</p> <hr/> <p>Series 610.0</p>

Relay 6	Lane 24	WHITEMAN Elizabeth
-------------------	-------------------	---------------------------

1-80	MDJRC	Precision	
------	-------	-----------	--

31.01.2025	2025 AirNats by X Count	Civilian Marksmanship Program	
------------	-------------------------	-------------------------------	--

Comment	Signature		
---------	-----------	--	--

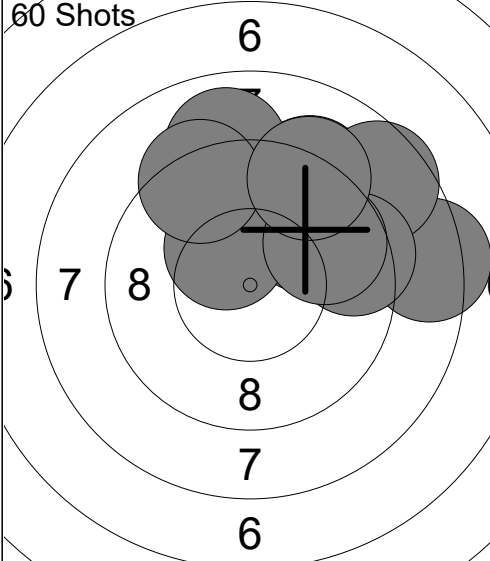
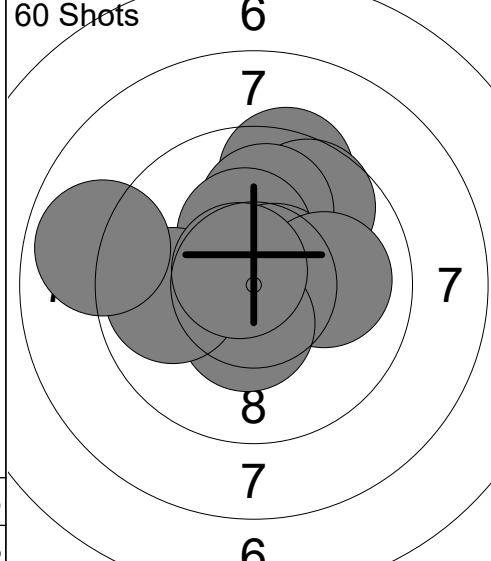
60 Shots 	1: 8.3 → 2: 9.2 ↗ 3: 9.0 ↑ 4: 8.6 ↗ 5: 9.8 ↗ 6: 9.4 → 7: 10.3x ↖ 8: 9.7 ↗ 9: 9.3 ↖ 10: 9.2 ↗ <hr/> Series 92.8 92.8	60 Shots 	11: 9.4 ↗ 12: 9.7 ↗ 13: 10.0 ↑ 14: 10.3x ↑ 15: 10.6x ↗ 16: 10.0 → 17: 10.4x ↓ 18: 9.9 ← 19: 8.9 ← 20: 10.7x ↖ <hr/> Series 99.9 192.7
--	--	--	--

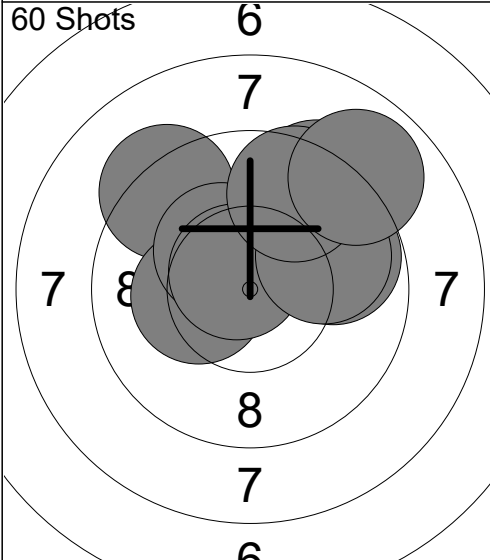
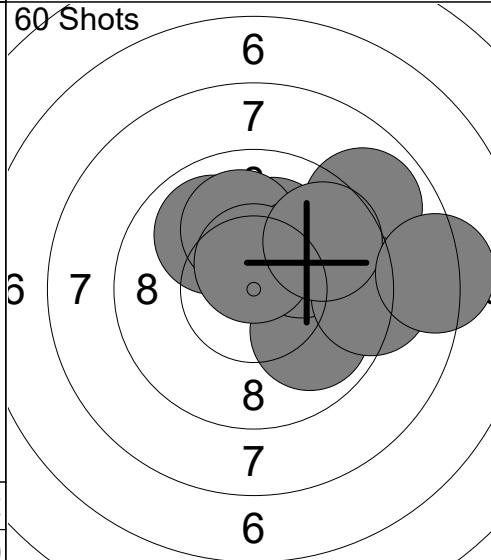
60 Shots 	21: 9.1 ↗ 22: 9.8 → 23: 9.3 ↖ 24: 10.3x ← 25: 10.3x ↖ 26: 9.3 ↗ 27: 10.7x ↖ 28: 9.9 → 29: 9.6 ↗ 30: 8.9 ↗ <hr/> Series 97.2 289.9	60 Shots 	31: 9.9 ↘ 32: 8.9 ↗ 33: 10.1 ↑ 34: 9.9 ↖ 35: 10.0 ↑ 36: 10.1 ↗ 37: 9.2 → 38: 10.6x ↑ 39: 9.7 ↗ 40: 8.2 → <hr/> Series 96.6 386.5
---	--	---	---

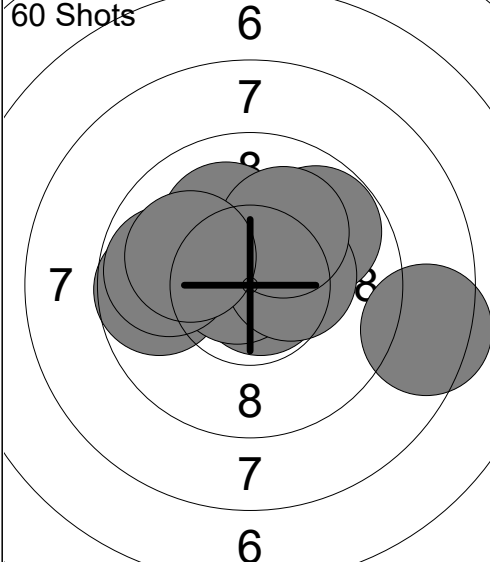
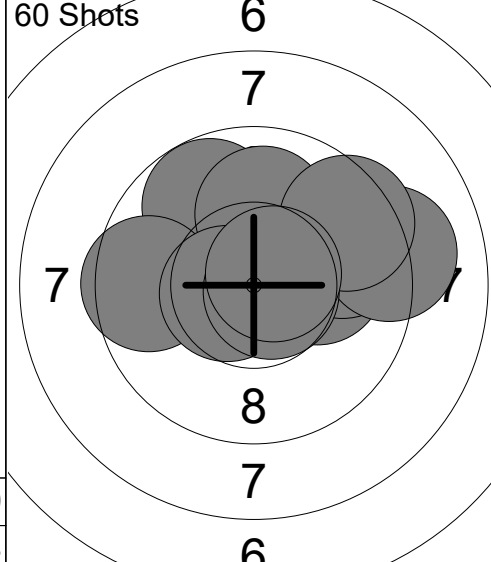
60 Shots 	41: 10.8x ⇒ 42: 9.7 ← 43: 10.7x ↖ 44: 9.8 ↗ 45: 10.4x → 46: 10.1 ↖ 47: 10.1 ↗ 48: 9.8 ← 49: 8.5 ⇒ 50: 10.0 ← <hr/> Series 99.9 486.4	60 Shots 	51: 9.8 ↖ 52: 10.1 → 53: 9.6 ← 54: 9.7 ↗ 55: 10.0 ↑ 56: 10.6x ← 57: 9.1 → 58: 9.5 ↗ 59: 10.7x ⇒ 60: 10.6x ↗ <hr/> Series 99.7 586.1
--	---	--	--

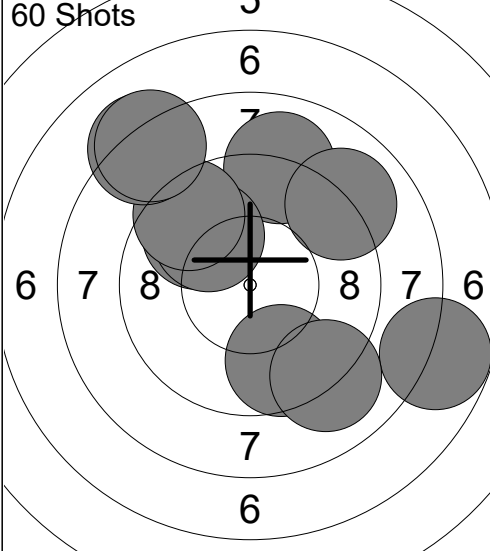
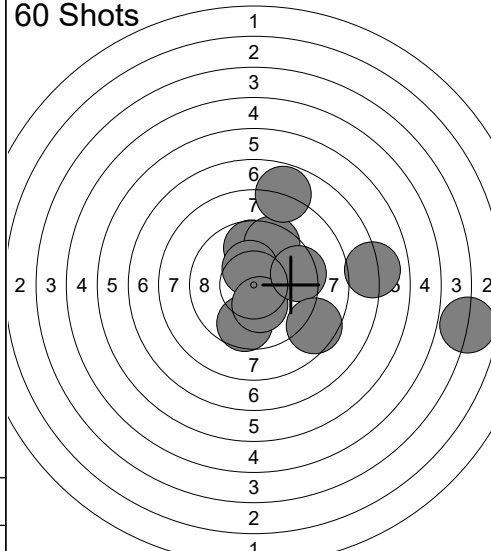
<p>60 Shots</p>  <p style="text-align: center;">6 7 8 8 7 6 7 6</p>	<p>1: 9.0 ↑ 2: 7.8 → 3: 9.8 ↗ 4: 9.9 ↗ 5: 9.5 ↗ 6: 8.2 ↗ 7: 8.2 ↗ 8: 9.0 → 9: 9.6 ↓ 10: 9.1 ↓</p> <p>Series 90.1 90.1</p>	<p>60 Shots</p>  <p style="text-align: center;">1 2 3 4 5 6 7 7 7 6 5 4 3 2 1</p> <p>11: 9.7 ↑ 12: 9.5 ↑ 13: 3.9 → 14: 7.8 ↑ 15: 10.4x ↑ 16: 9.7 ↓ 17: 10.3x ↓ 18: 9.4 → 19: 7.1 → 20: 8.6 →</p> <p>Series 86.4 176.5</p>
---	---	---

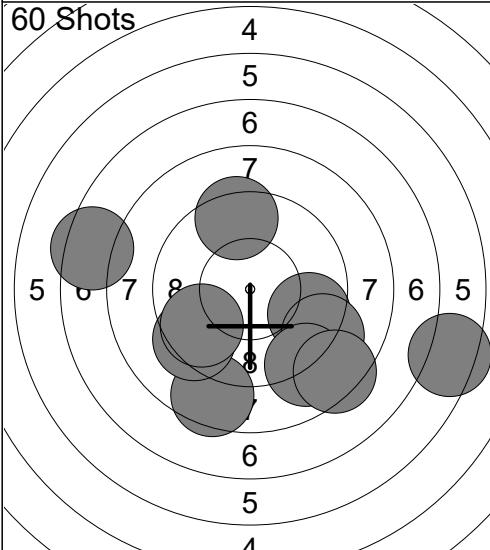
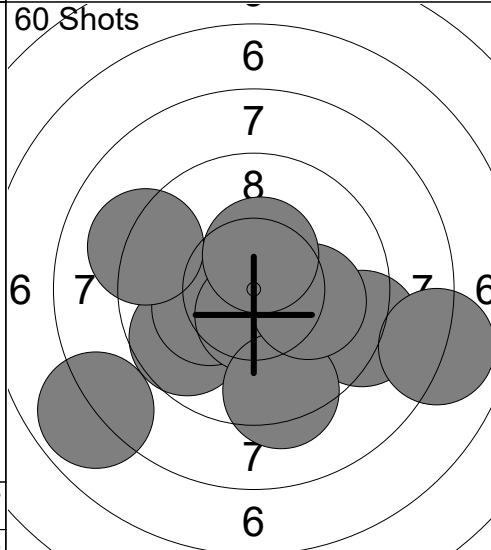
<p>60 Shots</p>  <p style="text-align: center;">4 5 6 7 8 7 7 6 5 6 5 4</p>	<p>21: 7.4 ← 22: 9.6 → 23: 9.1 ↓ 24: 8.5 ↓ 25: 9.3 ← 26: 6.4 → 27: 8.9 ↓ 28: 9.7 ← 29: 9.4 ↑ 30: 8.4 ↓</p> <p>Series 86.7 263.2</p>	<p>60 Shots</p>  <p style="text-align: center;">6 7 8 7 7 6 7 6 7 6 6</p> <p>31: 9.7 ↙ 32: 9.2 → 33: 7.9 ↙ 34: 10.2x ← 35: 9.2 ↖ 36: 10.6x ↓ 37: 9.3 ↓ 38: 10.1 → 39: 10.4x ↑ 40: 8.0 →</p> <p>Series 94.6 357.8</p>
--	---	---

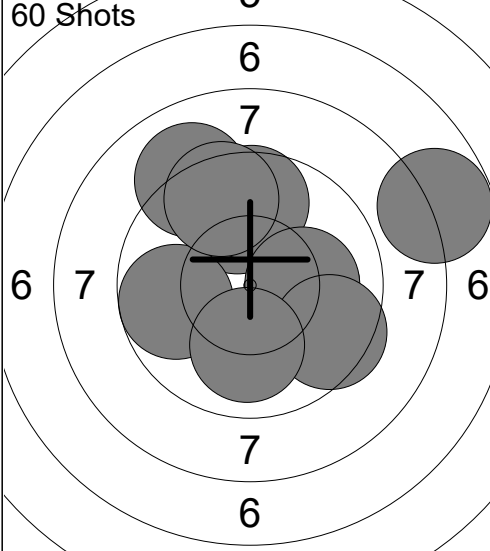
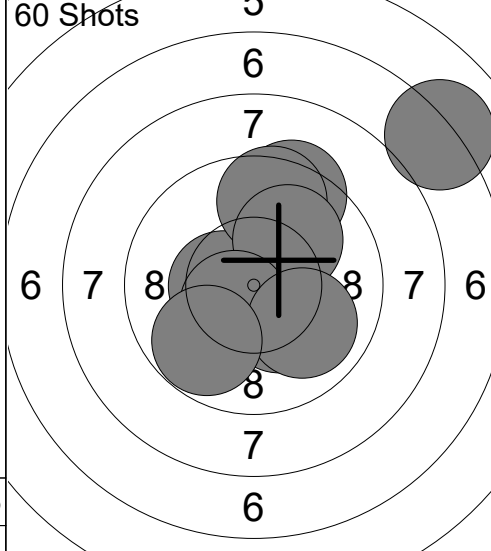
<p>60 Shots</p>  <p style="text-align: center;">6 7 7 6 7 6 7 6</p>	<p>41: 9.8 ↑ 42: 9.1 ↗ 43: 9.7 ↑ 44: 10.0 → 45: 10.1 → 46: 7.8 → 47: 9.5 → 48: 9.8 ← 49: 10.0 ↓ 50: 9.5 ↑</p> <p>Series 95.3 453.1</p>	<p>60 Shots</p>  <p style="text-align: center;">5 6 7 8 8 7 6 7 6 6 5</p> <p>51: 10.3x ↓ 52: 9.6 ↑ 53: 10.5x ← 54: 9.4 ↑ 55: 7.1 ↗ 56: 9.6 ↑ 57: 10.0 ↗ 58: 10.5x ↙ 59: 10.0 → 60: 9.8 ↙</p> <p>Series 96.8 549.9</p>
---	--	---

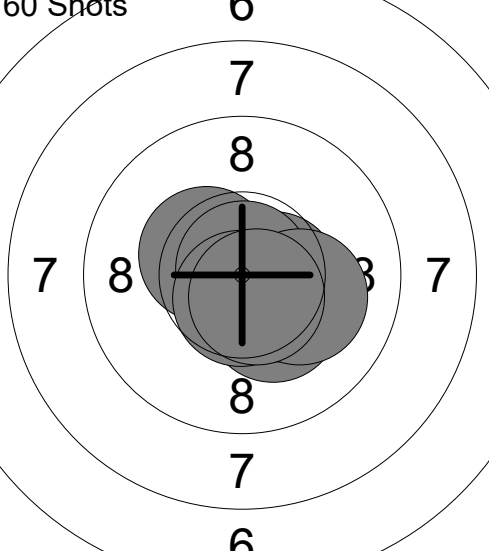
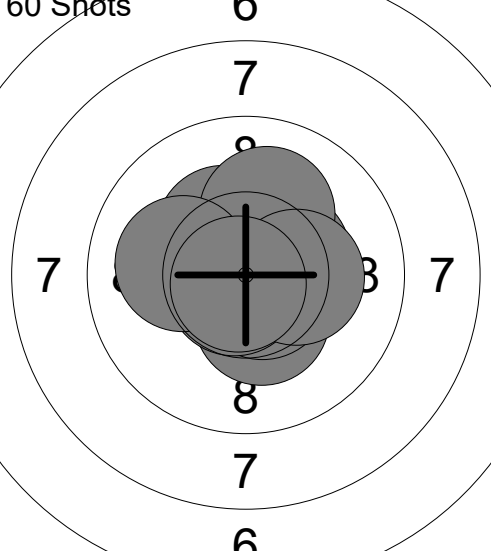
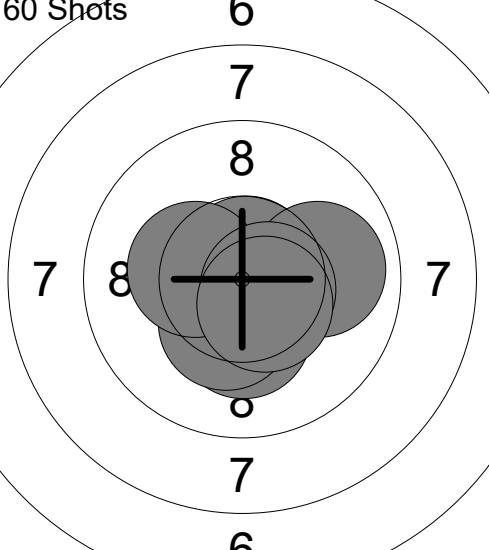
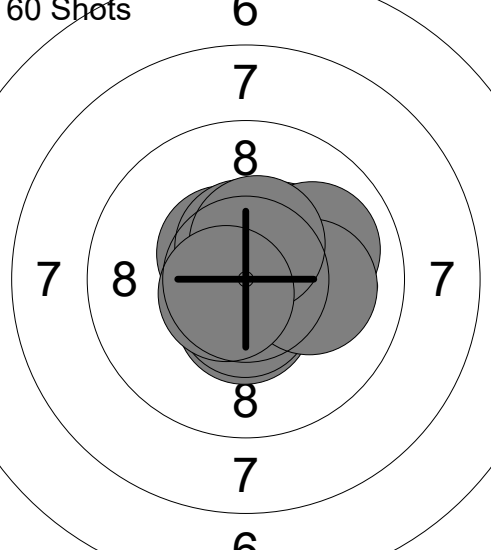
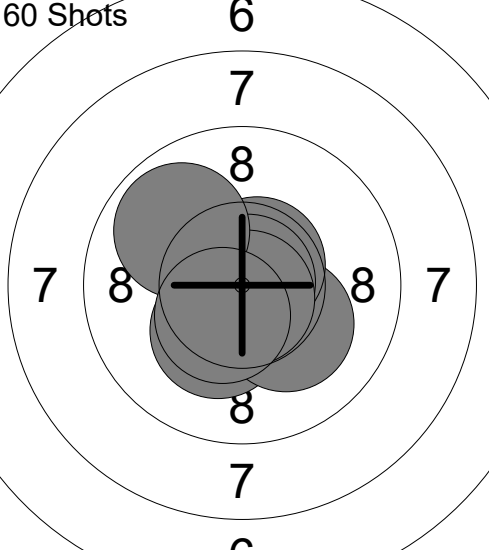
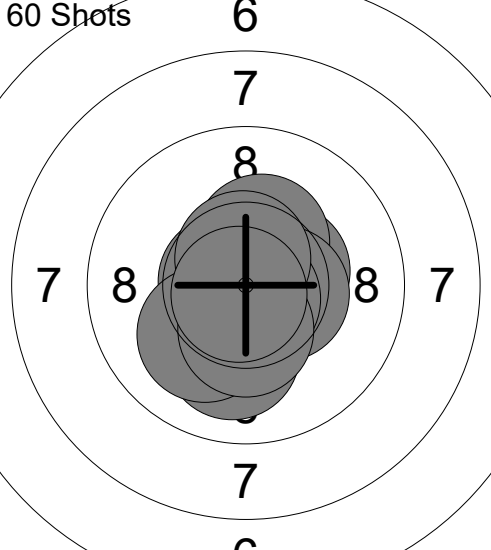
<p>60 Shots</p>  <p style="text-align: center;">6 7 8 7</p>	<p>1: 10.3x ↘ 2: 10.4x ↖ 3: 10.6x → 4: 10.7x ↓ 5: 10.5x → 6: 10.4x → 7: 10.9x ↑ 8: 10.6x ↓ 9: 10.1 → 10: 10.6x ↓</p> <p>Series 105.1 105.1</p>	<p>60 Shots</p>  <p style="text-align: center;">6 7 8 7</p>	<p>11: 10.4x ↓ 12: 10.5x ↖ 13: 10.6x ↓ 14: 10.3x ↖ 15: 10.4x → 16: 10.7x ↙ 17: 10.1 ↑ 18: 10.3x → 19: 10.1 ← 20: 10.8x ↙</p> <p>Series 104.2 209.3</p>
<p>60 Shots</p>  <p style="text-align: center;">6 7 8 7</p>	<p>21: 10.8x ↑ 22: 10.8x ↙ 23: 10.7x ↑ 24: 10.4x ↓ 25: 10.3x ↓ 26: 10.3x ↓ 27: 10.3x ← 28: 9.9 → 29: 10.6x → 30: 10.5x ↓</p> <p>Series 104.6 313.9</p>	<p>60 Shots</p>  <p style="text-align: center;">6 7 8 7</p>	<p>31: 10.5x ↓ 32: 10.8x ↓ 33: 10.4x ↗ 34: 10.0 → 35: 10.5x ↖ 36: 10.5x ↓ 37: 10.1 → 38: 10.5x ↑ 39: 10.5x ↑ 40: 10.6x ↙</p> <p>Series 104.4 418.3</p>
<p>60 Shots</p>  <p style="text-align: center;">6 7 8 7 6</p>	<p>41: 10.3x ↓ 42: 10.7x ↖ 43: 10.8x ↑ 44: 10.7x → 45: 10.2x ↓ 46: 10.6x ↗ 47: 10.9x ↗ 48: 10.8x ↓ 49: 9.9 ↖ 50: 10.5x ↓</p> <p>Series 105.4 523.7</p>	<p>60 Shots</p>  <p style="text-align: center;">6 7 8 7 6</p>	<p>51: 10.4x → 52: 10.3x ↑ 53: 10.0 ↓ 54: 10.5x → 55: 10.7x ← 56: 10.7x ↓ 57: 10.1 ↙ 58: 10.4x ↓ 59: 10.6x ↑ 60: 10.8x ↙</p> <p>Series 104.5 628.2</p>

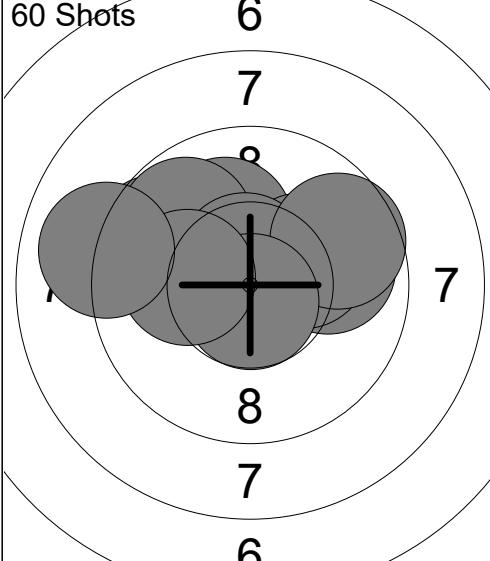
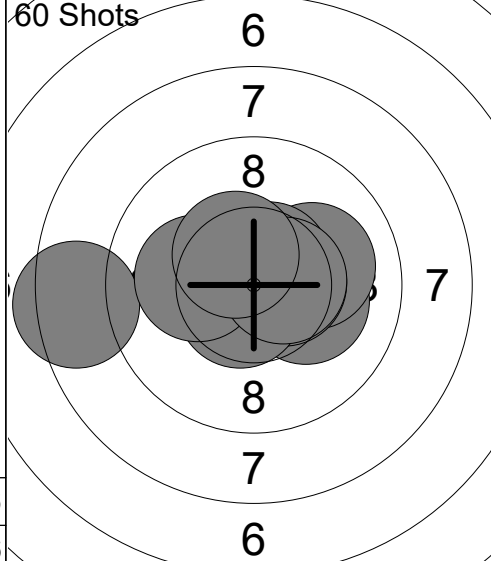
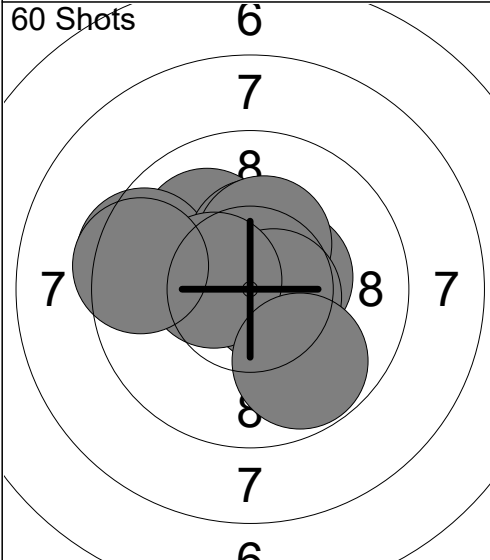
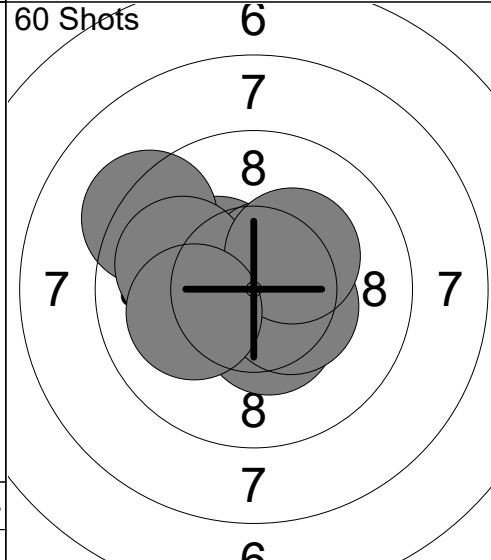
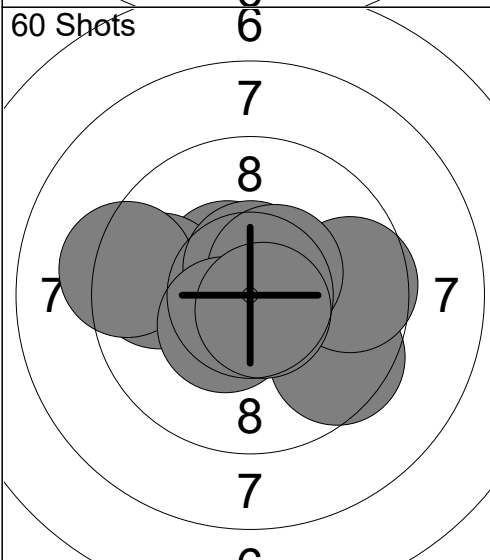
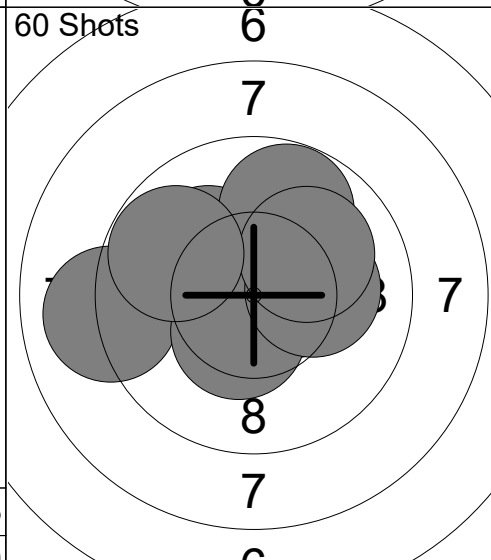
<p>60 Shots</p> 	<p>1: 10.1 ↗ 2: 9.6 ↖ 3: 9.9 → 4: 9.8 ↖ 5: 10.2x → 6: 10.6x ↗ 7: 9.6 → 8: 10.7x ↓ 9: 10.1 ← 10: 9.0 ←</p> <p>Series 99.6</p>	<p>60 Shots</p> 	<p>11: 10.2x ⇒ 12: 10.1 → 13: 10.6x → 14: 10.5x → 15: 10.6x ↗ 16: 8.4 ← 17: 10.6x ↘ 18: 10.2x ← 19: 10.5x → 20: 10.4x ↖</p> <p>Series 102.1</p>
	99.6		201.7
<p>60 Shots</p> 	<p>21: 10.3x ↗ 22: 10.0 ↗ 23: 9.5 ← 24: 10.5x → 25: 10.4x ↗ 26: 10.3x ↗ 27: 10.6x → 28: 10.5x ← 29: 9.8 ↘ 30: 9.5 ←</p> <p>Series 101.4</p>	<p>60 Shots</p> 	<p>31: 10.5x ↖ 32: 10.4x ↖ 33: 10.6x ↗ 34: 9.3 ← 35: 10.5x → 36: 10.0 ← 37: 10.4x ↘ 38: 10.4x → 39: 10.3x ↗ 40: 10.1 ←</p> <p>Series 102.5</p>
	303.1		405.6
<p>60 Shots</p> 	<p>41: 10.5x ↖ 42: 10.5x → 43: 9.7 ← 44: 9.3 ← 45: 9.5 ↘ 46: 10.6x ↗ 47: 9.6 → 48: 10.5x ↗ 49: 10.4x ↘ 50: 10.7x ↘</p> <p>Series 101.3</p>	<p>60 Shots</p> 	<p>51: 10.6x ← 52: 9.0 ← 53: 10.5x → 54: 10.6x ↖ 55: 10.1 ↖ 56: 10.4x ↘ 57: 10.2x → 58: 9.8 ↗ 59: 10.1 ↗ 60: 9.8 ←</p> <p>Series 101.1</p>
	506.9		608.0

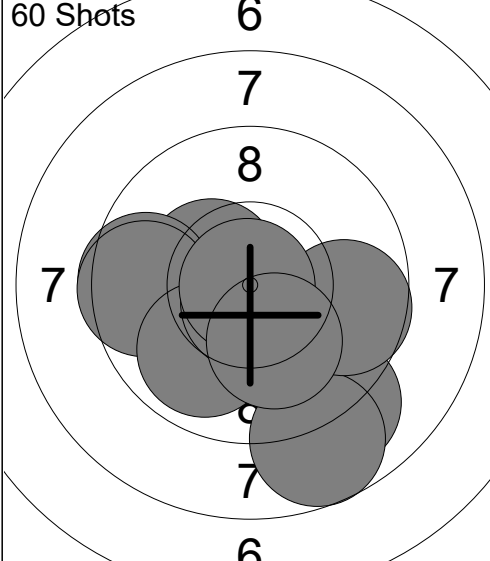
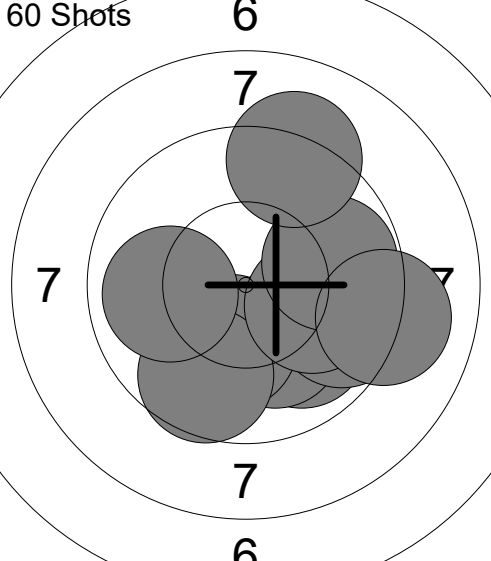
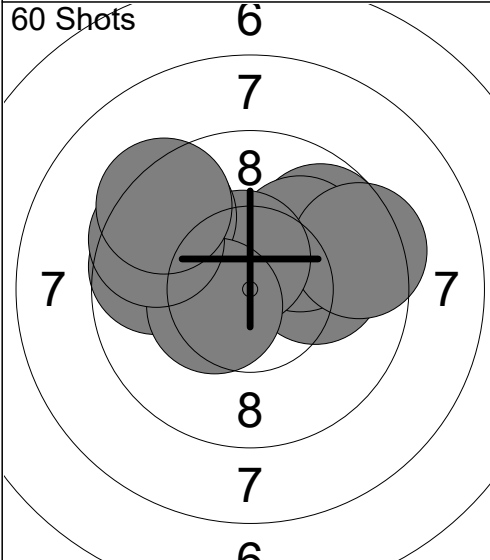
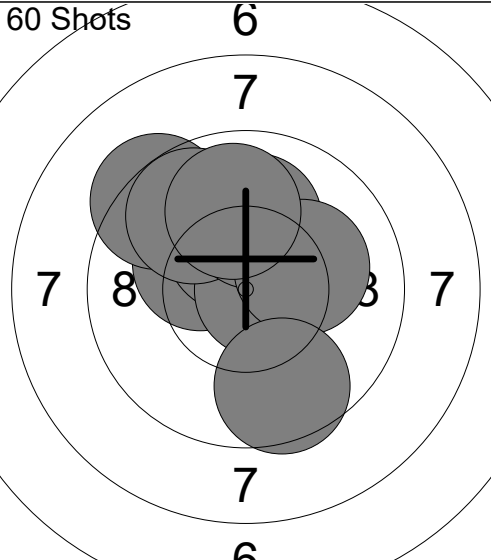
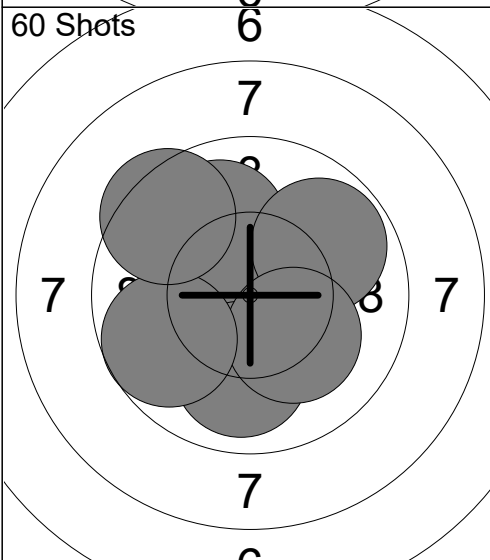
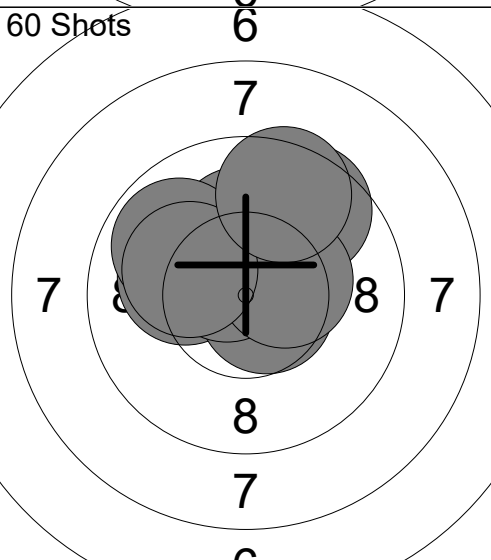
<p>60 Shots</p>  <p style="text-align: center;">6 7 8 7 7</p>	<p>1: 10.4x ↖ 2: 9.6 ← 3: 9.6 ← 4: 9.9 ↘ 5: 9.0 ↘ 6: 8.7 ↘ 7: 9.7 → 8: 10.7x ↓ 9: 10.9x ↙ 10: 10.1 ↓</p> <p>Series 98.6 98.6</p>	<p>60 Shots</p>  <p style="text-align: center;">6 7 7 7</p>	<p>11: 9.9 ↘ 12: 10.1 ↘ 13: 10.2x ↓ 14: 9.6 → 15: 9.6 ↓ 16: 10.0 → 17: 9.8 → 18: 9.1 → 19: 9.9 ← 20: 9.2 ↑</p> <p>Series 97.4 196.0</p>
<p>60 Shots</p>  <p style="text-align: center;">6 6 7 8 7 7</p>	<p>21: 10.1 → 22: 9.7 ↗ 23: 10.1 ↗ 24: 9.7 ← 25: 9.4 → 26: 10.5x ↑ 27: 9.5 ↗ 28: 10.4x ← 29: 9.5 ↗ 30: 9.4 ↗</p> <p>Series 98.3 294.3</p>	<p>60 Shots</p>  <p style="text-align: center;">6 6 7 7 7</p>	<p>31: 10.3x ↖ 32: 10.3x ↖ 33: 9.3 ↖ 34: 10.3x ↑ 35: 10.7x → 36: 9.8 ↖ 37: 10.0 ↑ 38: 10.2x → 39: 9.9 ↑ 40: 9.6 ↓</p> <p>Series 100.4 394.7</p>
<p>60 Shots</p>  <p style="text-align: center;">6 6 7 7 7 6</p>	<p>41: 10.3x ↗ 42: 10.8x ↓ 43: 10.7x ↓ 44: 10.6x ↓ 45: 10.0 ↗ 46: 9.8 ↗ 47: 10.0 ↓ 48: 10.2x ↓ 49: 9.7 ← 50: 9.4 ↗</p> <p>Series 101.5 496.2</p>	<p>60 Shots</p>  <p style="text-align: center;">6 6 7 7 8 7 6</p>	<p>51: 10.3x ↗ 52: 10.1 ← 53: 10.6x → 54: 10.6x ↖ 55: 10.1 ↑ 56: 9.6 ↗ 57: 9.9 ↖ 58: 10.4x → 59: 10.1 ← 60: 9.5 ↑</p> <p>Series 101.2 597.4</p>

Relay 6	Lane 29	STONIER Tucker
-------------------	-------------------	-----------------------

1-80	AL Post 109 1	Precision	
------	---------------	-----------	--

31.01.2025	2025 AirNats by X Count	Civilian Marksmanship Program	
------------	-------------------------	-------------------------------	--

Comment	Signature		
---------	-----------	--	--

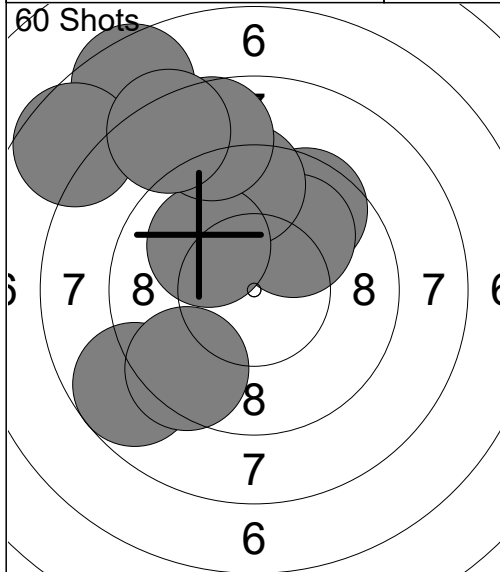

1:	9.6	↗
2:	8.7	↖
3:	7.5	↗
4:	9.5	↖
5:	10.0	↗
6:	9.4	↑
7:	10.0	↗
8:	7.6	↗
9:	8.7	↑
10:	8.3	↗
Series		89.3
		89.3

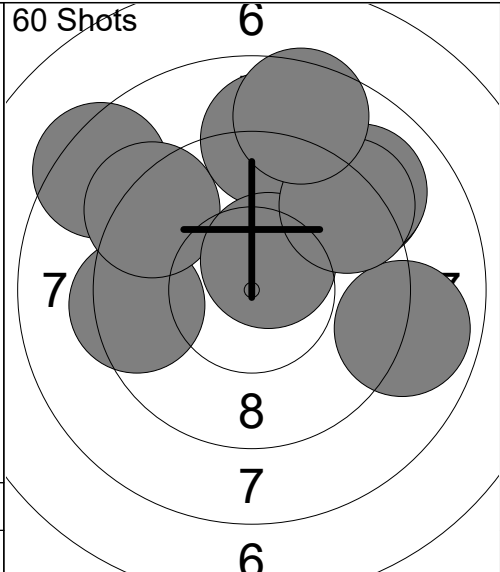

11:	9.1	↗
12:	8.4	↖
13:	8.9	→
14:	9.4	←
15:	9.0	↗
16:	9.3	↖
17:	8.9	↑
18:	10.5x	↗
19:	9.3	↗
20:	8.6	↑
Series		91.4
		180.7

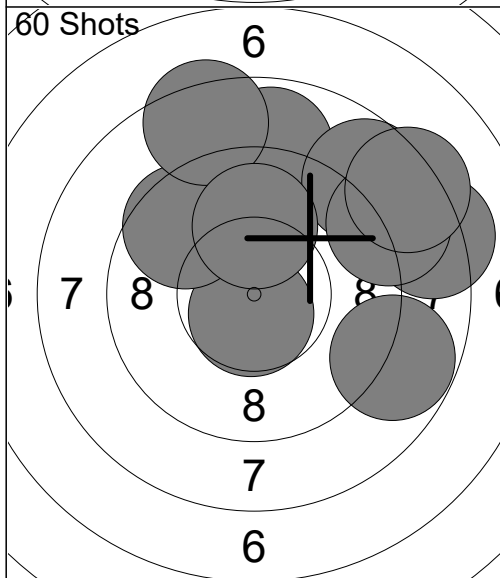

21:	8.3	→
22:	8.9	↑
23:	10.7x	↓
24:	9.6	↗
25:	8.7	↗
26:	8.8	→
27:	8.4	↑
28:	10.0	↑
29:	8.8	↗
30:	8.3	↗
Series		90.5
		271.2

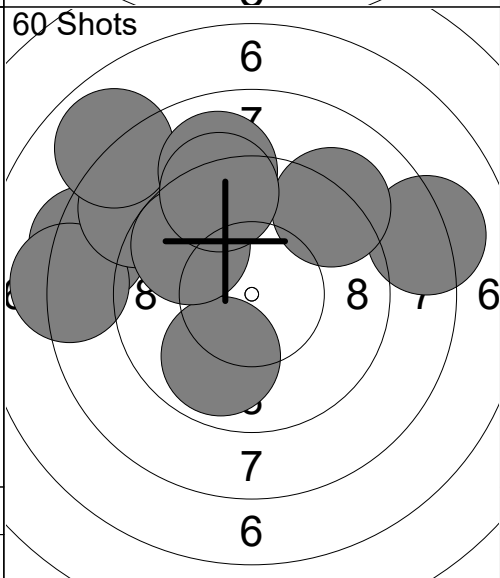

31:	8.4	←
32:	8.2	←
33:	8.8	↖
34:	7.9	↗
35:	8.2	→
36:	9.0	↑
37:	9.9	↓
38:	9.8	↖
39:	9.2	↗
40:	9.3	↑
Series		88.7
		359.9

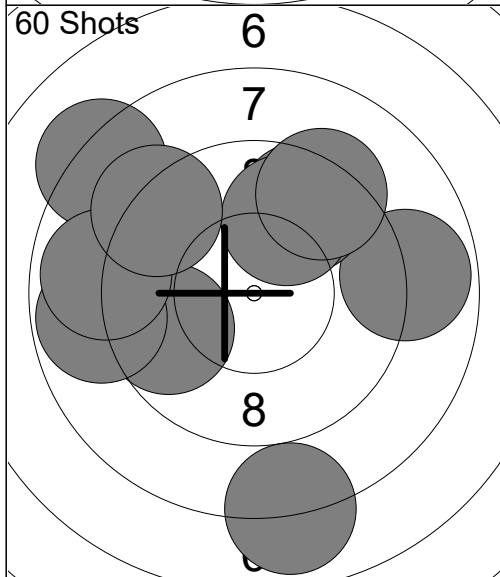

41:	8.9	→
42:	9.6	↗
43:	9.7	←
44:	9.8	↑
45:	8.8	←
46:	8.2	↖
47:	8.9	←
48:	9.3	↗
49:	7.9	↓
50:	9.2	↖
Series		90.3
		450.2

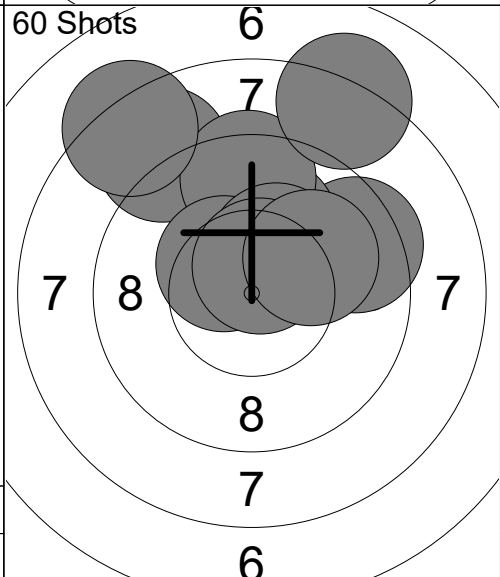

51:	9.4	↗
52:	8.8	↖
53:	10.0	↑
54:	9.4	↑
55:	10.4x	↖
56:	8.2	↖
57:	10.3x	↗
58:	10.6x	↑
59:	10.0	↗
60:	8.1	↑
Series		95.2
		545.4

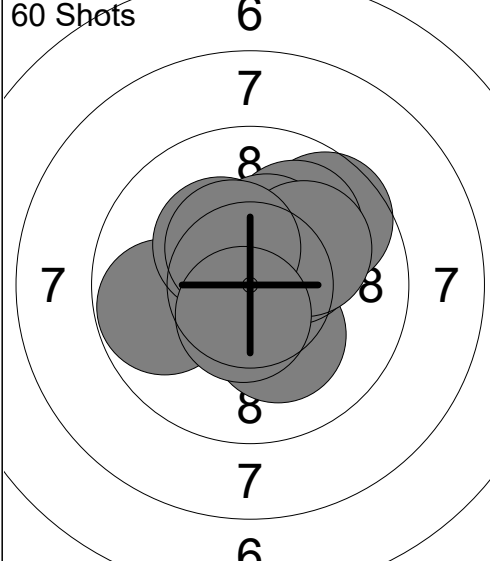
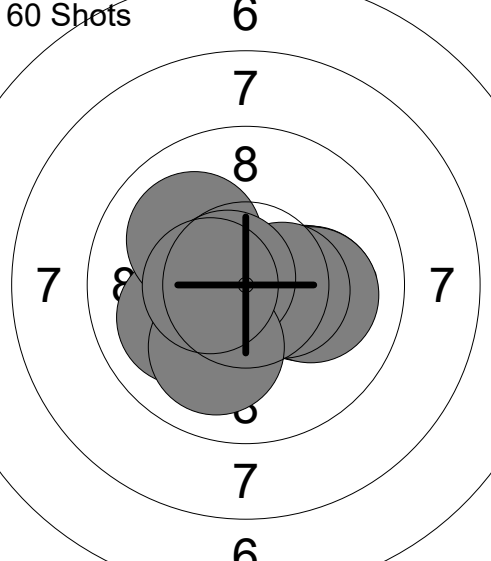
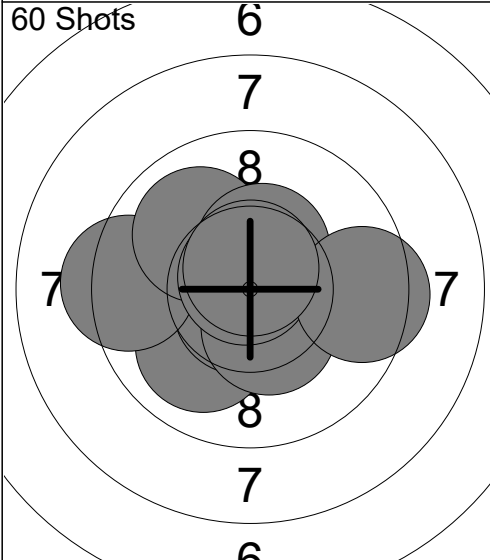
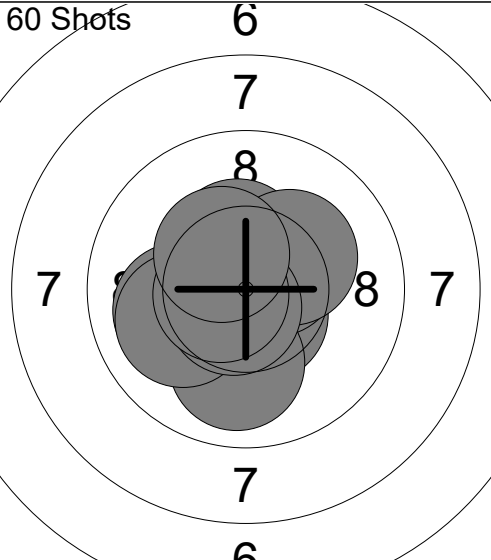
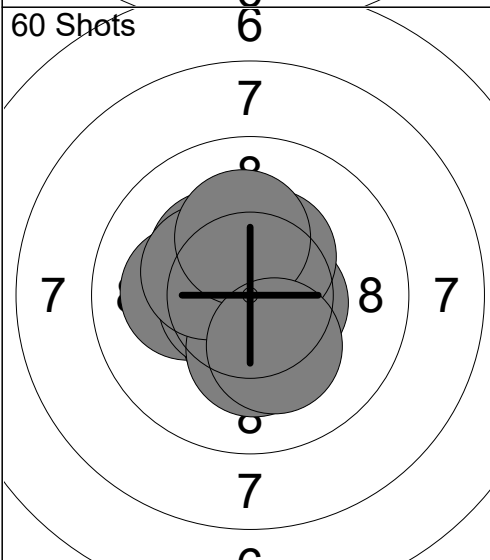
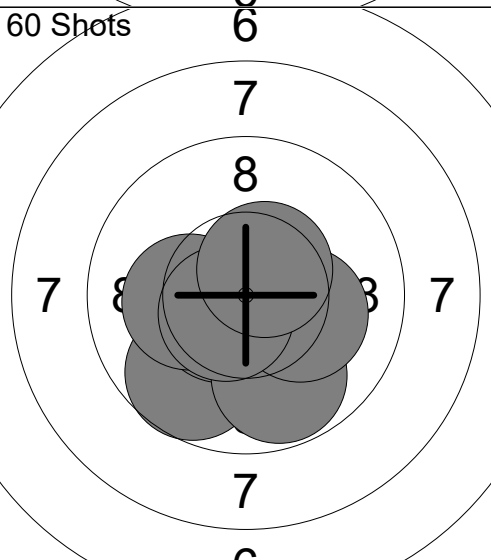
<p>60 Shots</p>  <p style="text-align: center;">6 7 8 7</p>	<p>1: 9.8 ← 2: 10.2x ↓ 3: 10.3x ↖ 4: 10.3x ↗ 5: 9.6 ↗ 6: 10.0 ↗ 7: 10.3x ↑ 8: 10.1 ↗ 9: 10.4x ↖ 10: 10.6x ↓</p> <p>Series 101.6 101.6</p>	<p>60 Shots</p>  <p style="text-align: center;">6 7 8 7</p>	<p>11: 10.0 ← 12: 10.2x → 13: 10.1 → 14: 10.1 → 15: 10.8x ↖ 16: 10.0 ↖ 17: 10.5x → 18: 10.7x ↖ 19: 10.0 ↓ 20: 10.5x ←</p> <p>Series 102.9 204.5</p>
<p>60 Shots</p>  <p style="text-align: center;">6 7 8 7</p>	<p>21: 10.0 ↓ 22: 10.6x ↖ 23: 10.7x ↓ 24: 9.3 ← 25: 10.4x ↓ 26: 10.0 ↖ 27: 10.4x ↑ 28: 10.8x ↖ 29: 9.5 → 30: 10.7x ↑</p> <p>Series 102.4 306.9</p>	<p>60 Shots</p>  <p style="text-align: center;">6 7 8 7</p>	<p>31: 10.6x ↓ 32: 10.5x ↗ 33: 10.4x ↑ 34: 10.0 ← 35: 10.2x ↗ 36: 10.0 ↓ 37: 10.0 ← 38: 10.7x ↓ 39: 10.6x ← 40: 10.4x ↖</p> <p>Series 103.4 410.3</p>
<p>60 Shots</p>  <p style="text-align: center;">6 7 8 7 6</p>	<p>41: 10.5x → 42: 10.1 ← 43: 10.4x ↓ 44: 10.3x ↖ 45: 10.6x ← 46: 10.4x ↗ 47: 10.2x ↓ 48: 10.3x ↖ 49: 10.2x ↑ 50: 10.2x ↓</p> <p>Series 103.2 513.5</p>	<p>60 Shots</p>  <p style="text-align: center;">6 7 8 7 6</p>	<p>51: 10.7x → 52: 10.3x → 53: 9.7 ↓ 54: 10.5x ↖ 55: 10.2x ← 56: 9.8 ↓ 57: 10.8x → 58: 10.2x → 59: 10.6x ↖ 60: 10.5x ↗</p> <p>Series 103.3 616.8</p>

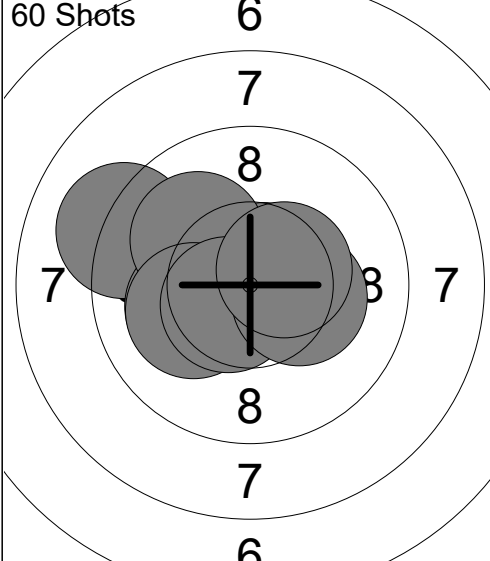
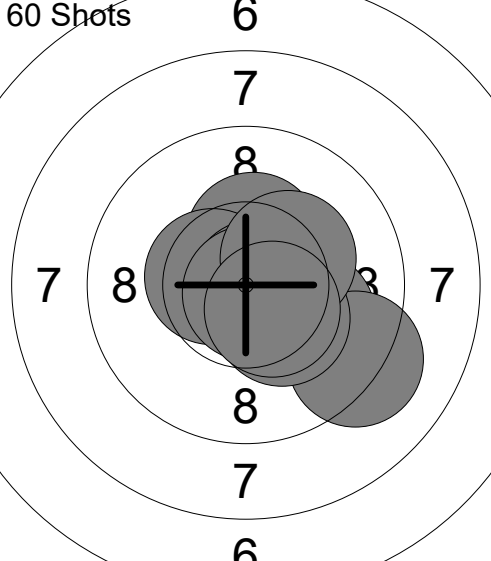
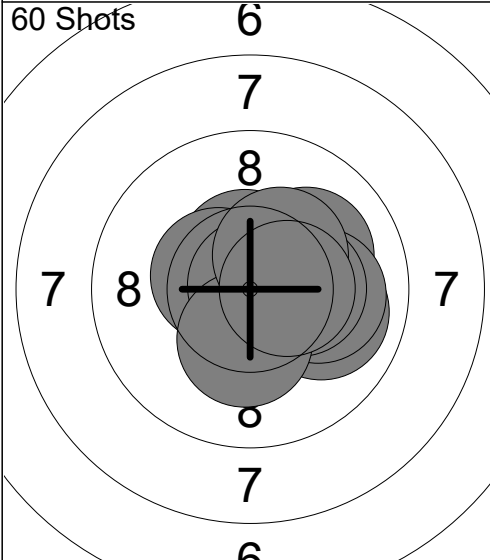
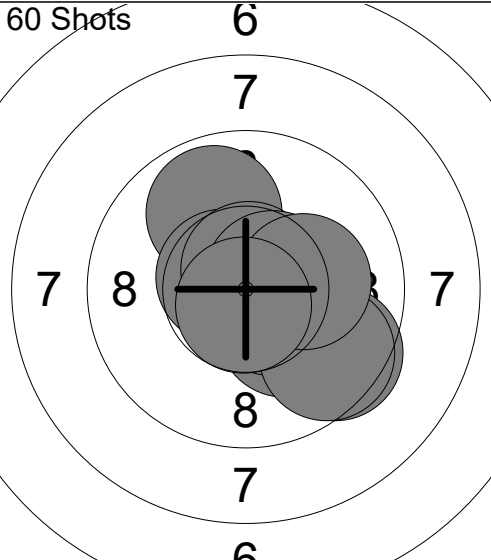
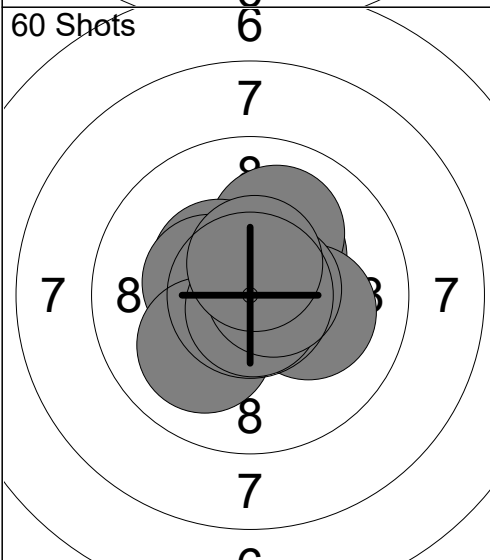
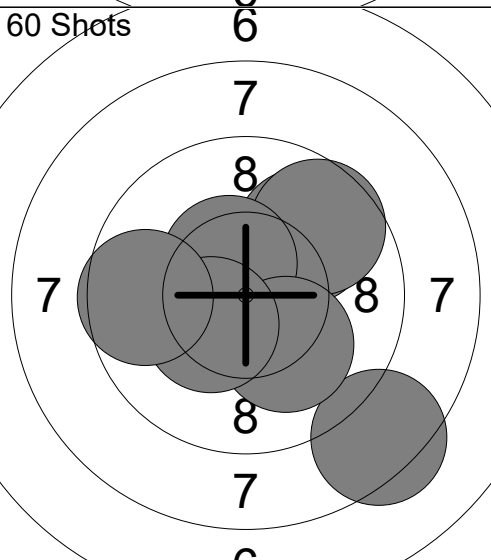
<p>60 Shots</p> 	<p>1: 10.7x →</p> <p>2: 10.7x ↖</p> <p>3: 9.1 ←</p> <p>4: 10.7x ↗</p> <p>5: 10.1 ←</p> <p>6: 10.0 ↖</p> <p>7: 10.1 ←</p> <p>8: 10.6x ↙</p> <p>9: 10.3x →</p> <p>10: 10.5x →</p> <hr/> <p>Series 102.8</p> <p style="text-align: center;">102.8</p>	<p>60 Shots</p> 	<p>11: 10.4x ↑</p> <p>12: 10.5x ←</p> <p>13: 10.8x →</p> <p>14: 10.0 ↘</p> <p>15: 10.6x →</p> <p>16: 9.2 ↘</p> <p>17: 10.3x ↘</p> <p>18: 10.8x ↘</p> <p>19: 10.3x ↗</p> <p>20: 10.5x ↘</p> <hr/> <p>Series 103.4</p> <p style="text-align: center;">206.2</p>
<p>60 Shots</p> 	<p>21: 10.5x ↑</p> <p>22: 10.5x ←</p> <p>23: 10.1 ↗</p> <p>24: 10.0 →</p> <p>25: 10.0 →</p> <p>26: 10.9x ↗</p> <p>27: 10.3x →</p> <p>28: 10.3x ↓</p> <p>29: 10.3x ↗</p> <p>30: 10.5x →</p> <hr/> <p>Series 103.4</p> <p style="text-align: center;">309.6</p>	<p>60 Shots</p> 	<p>31: 9.9 ↑</p> <p>32: 10.2x ↘</p> <p>33: 10.6x ←</p> <p>34: 10.7x ↑</p> <p>35: 9.5 ↘</p> <p>36: 10.5x ↘</p> <p>37: 9.6 ↘</p> <p>38: 10.6x →</p> <p>39: 10.2x →</p> <p>40: 10.7x ↓</p> <hr/> <p>Series 102.5</p> <p style="text-align: center;">412.1</p>
<p>60 Shots</p> 	<p>41: 10.3x ↗</p> <p>42: 10.1 ↑</p> <p>43: 10.4x ↖</p> <p>44: 10.7x ↙</p> <p>45: 10.4x ←</p> <p>46: 10.1 ↙</p> <p>47: 10.2x →</p> <p>48: 10.8x ↓</p> <p>49: 10.6x →</p> <p>50: 10.5x ↑</p> <hr/> <p>Series 104.1</p> <p style="text-align: center;">516.2</p>	<p>60 Shots</p> 	<p>51: 10.8x ↗</p> <p>52: 10.5x ←</p> <p>53: 10.6x ←</p> <p>54: 9.9 ↗</p> <p>55: 9.6 ↗</p> <p>56: 10.5x ↑</p> <p>57: 8.4 ↘</p> <p>58: 10.1 ↘</p> <p>59: 10.3x ↙</p> <p>60: 9.6 ←</p> <hr/> <p>Series 100.3</p> <p style="text-align: center;">616.5</p>

Relay 6	Lane 32	MITCHELL Molly
-------------------	-------------------	-----------------------

1-80	Yellowstone Rifle Club	Precision	
------	------------------------	-----------	--

31.01.2025	2025 AirNats by X Count	Civilian Marksmanship Program	
------------	-------------------------	-------------------------------	--

Comment	Signature		
---------	-----------	--	--

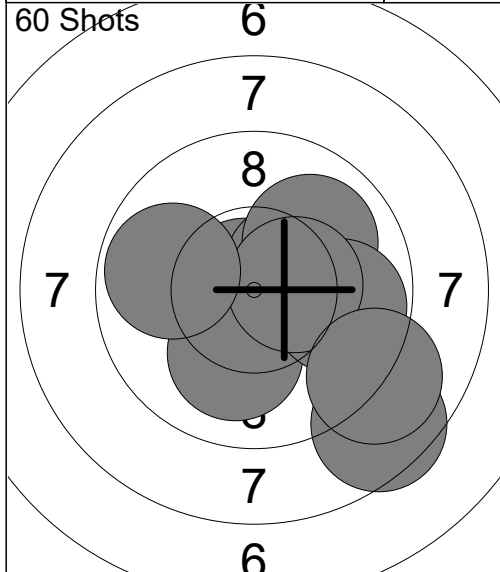

1:	10.8x	↗
2:	8.5	↘
3:	10.8x	↖
4:	10.4x	↗
5:	10.0	↗
6:	10.1	↘
7:	9.8	→
8:	10.4x	→
9:	9.0	↘
10:	9.8	↖
Series	99.6	
	99.6	

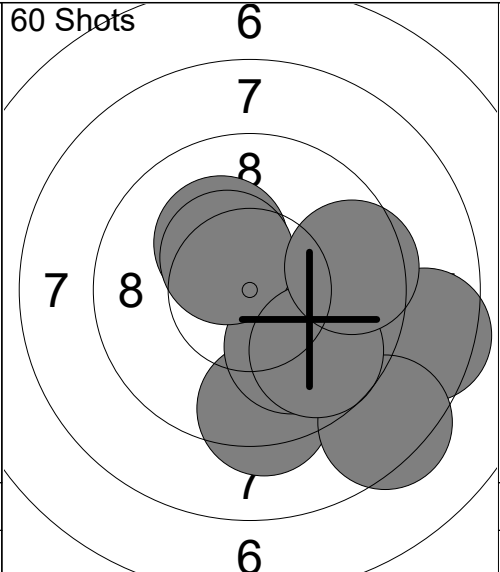

11:	10.1	↘
12:	9.9	↗
13:	10.2x	↗
14:	9.3	↘
15:	8.5	→
16:	8.4	↘
17:	10.0	↘
18:	10.4x	↗
19:	9.7	↘
20:	9.5	→
Series	96.0	
	195.6	

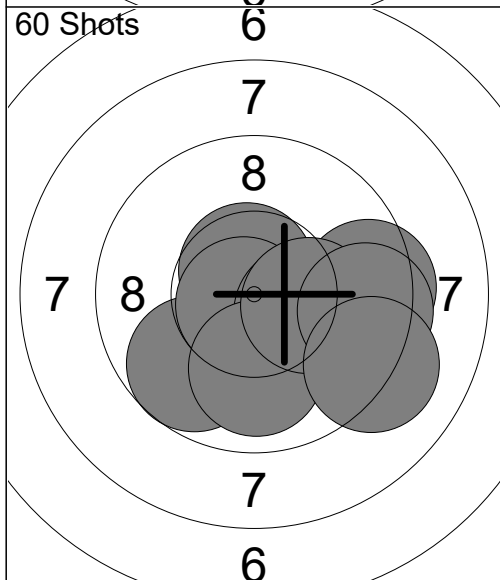

21:	10.8x	↗
22:	10.6x	↗
23:	9.7	↘
24:	10.7x	↖
25:	9.4	→
26:	10.3x	→
27:	10.0	↘
28:	10.2x	→
29:	9.5	→
30:	9.1	↘
Series	100.3	
	295.9	

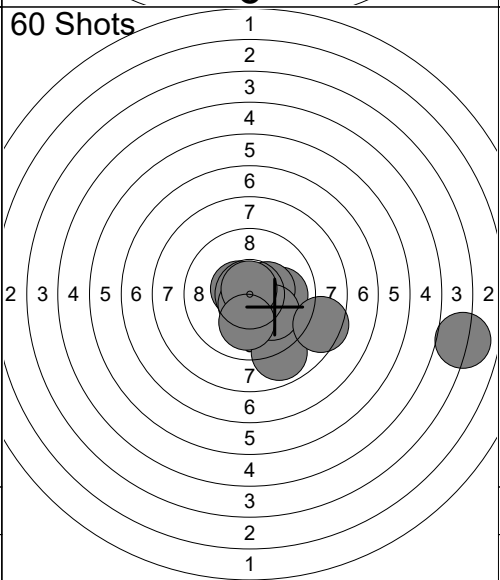

31:	8.9	↘
32:	10.5x	↖
33:	10.0	→
34:	10.6x	↘
35:	10.4x	→
36:	10.0	↘
37:	4.0	→
38:	8.5	→
39:	10.8x	↗
40:	10.1	↘
Series	93.8	
	389.7	

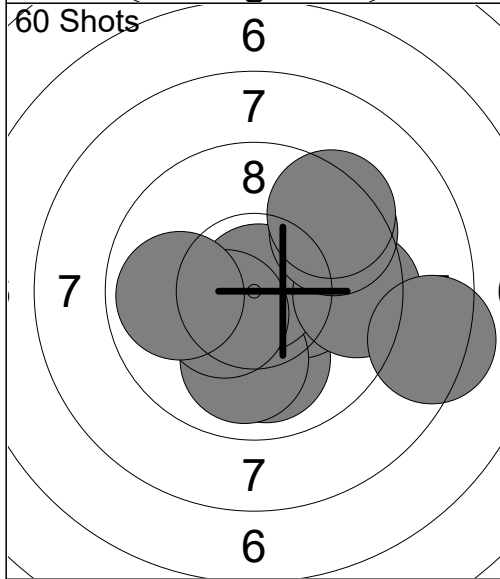

41:	10.0	↘
42:	10.3x	→
43:	10.0	↘
44:	10.9x	↗
45:	9.5	→
46:	10.4x	↖
47:	9.9	↖
48:	9.6	↗
49:	9.4	↗
50:	8.4	→
Series	98.4	
	488.1	

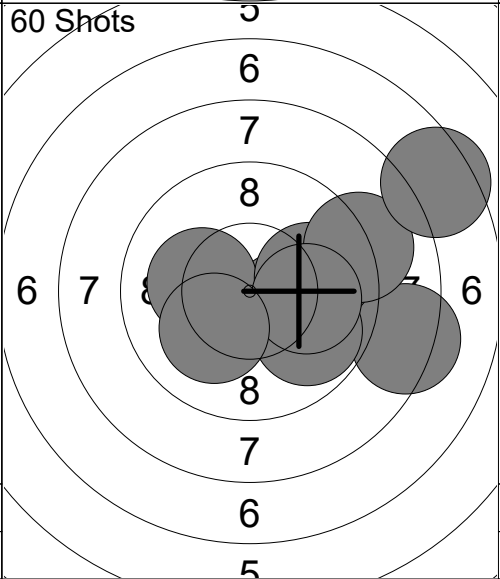

51:	10.3x	→
52:	10.2x	↖
53:	9.5	→
54:	10.0	→
55:	8.3	→
56:	9.8	↘
57:	9.0	↗
58:	10.0	→
59:	10.1	↖
60:	7.5	↗
Series	94.7	
	582.8	

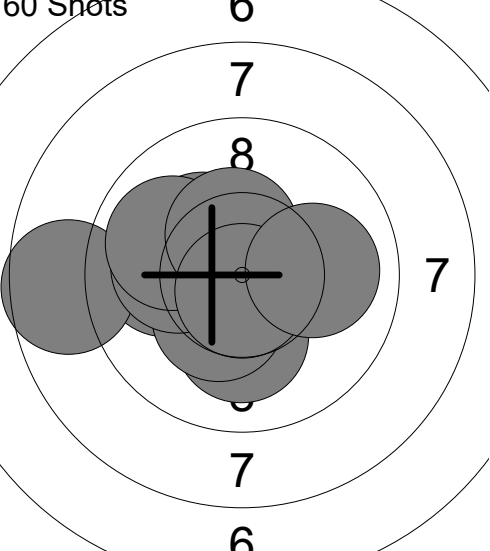
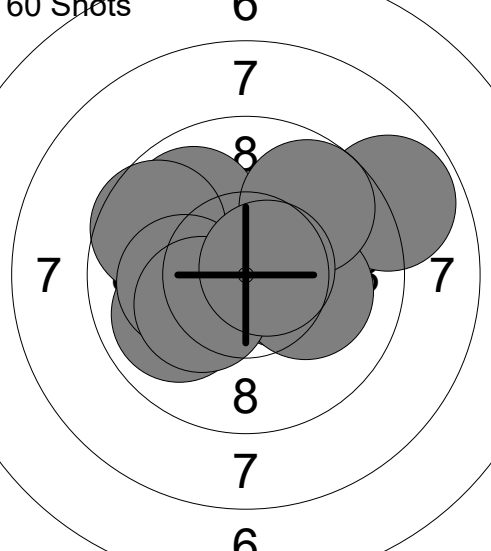
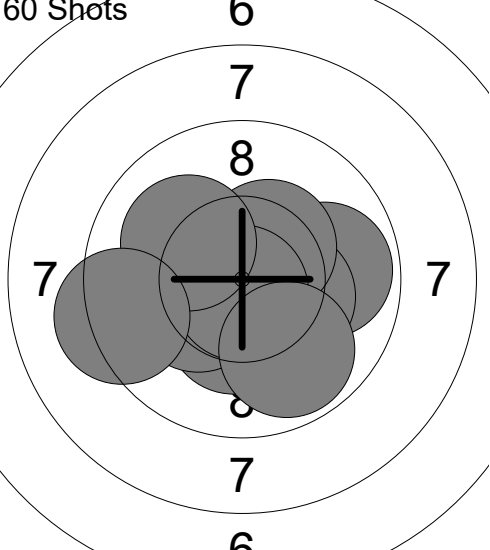
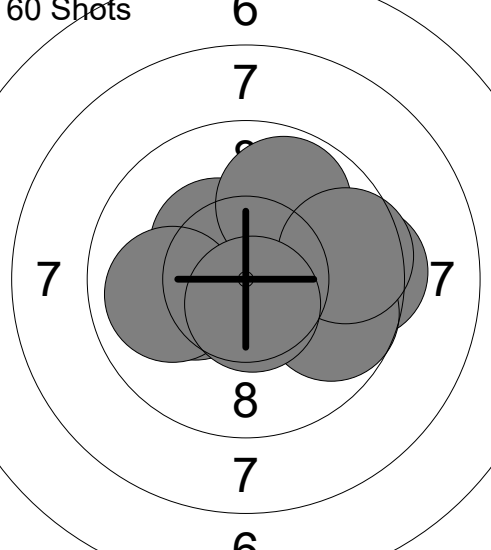
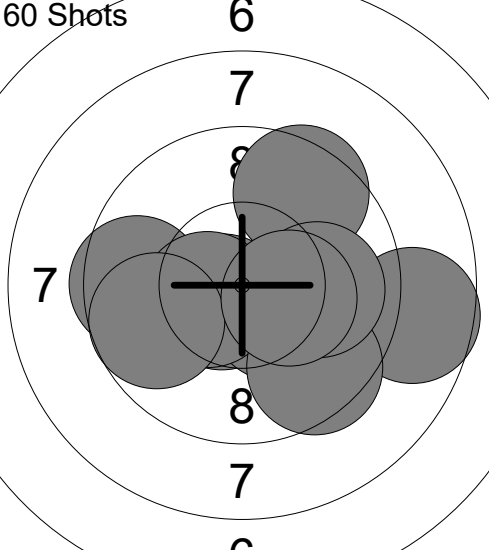
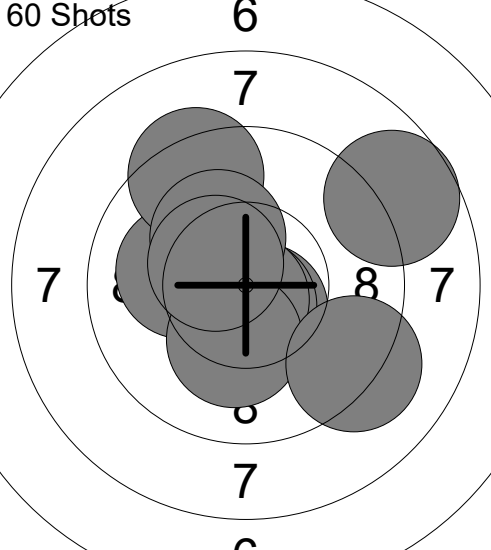
<p>60 Shots</p>  <p style="text-align: center;">6 7 8 7</p>	<p>1: 9.9 ← 2: 10.1 ↓ 3: 8.6 ← 4: 10.3x ↓ 5: 10.1 ← 6: 10.2x ↗ 7: 9.9 ↖ 8: 10.4x ↑ 9: 10.7x ↓ 10: 10.0 →</p> <p>Series 100.2 100.2</p>	<p>60 Shots</p>  <p style="text-align: center;">6 7 8 7</p>	<p>11: 9.9 ↖ 12: 8.8 ↗ 13: 10.4x → 14: 9.9 ↖ 15: 9.6 ↖ 16: 10.1 ← 17: 10.1 → 18: 9.7 ↗ 19: 10.2x ↖ 20: 10.7x →</p> <p>Series 99.4 199.6</p>
<p>60 Shots</p>  <p style="text-align: center;">6 7 8 7</p>	<p>21: 10.4x → 22: 10.3x ↓ 23: 9.9 → 24: 10.3x ↖ 25: 10.3x → 26: 10.4x ↗ 27: 10.8x ↓ 28: 10.1 ↖ 29: 9.8 ↓ 30: 9.3 ←</p> <p>Series 101.6 301.2</p>	<p>60 Shots</p>  <p style="text-align: center;">6 7 8 7</p>	<p>31: 10.7x ↖ 32: 9.4 → 33: 10.1 ↗ 34: 10.3x ↖ 35: 10.4x ↖ 36: 10.0 ← 37: 9.8 ↑ 38: 9.7 → 39: 9.6 → 40: 10.6x ↓</p> <p>Series 100.6 401.8</p>
<p>60 Shots</p>  <p style="text-align: center;">6 7 8 7 6</p>	<p>41: 8.7 → 42: 9.6 ← 43: 10.6x ↖ 44: 10.4x ↘ 45: 9.5 ↗ 46: 10.5x ↖ 47: 9.5 ↓ 48: 10.0 → 49: 9.7 ← 50: 10.3x →</p> <p>Series 98.8 500.6</p>	<p>60 Shots</p>  <p style="text-align: center;">6 7 8 7 6</p>	<p>51: 10.6x ↓ 52: 10.7x ↓ 53: 10.1 ← 54: 9.4 ↗ 55: 10.8x ↓ 56: 10.2x ↓ 57: 9.2 → 58: 8.7 ↗ 59: 10.2x ↖ 60: 10.5x ↖</p> <p>Series 100.4 601.0</p>

Relay 6	Lane 34	GREEN Dean
-------------------	-------------------	-------------------

1-80	Yellowstone Rifle Club	Precision	
------	------------------------	-----------	--

31.01.2025	2025 AirNats by X Count	Civilian Marksmanship Program	
------------	-------------------------	-------------------------------	--

Comment	Signature		
---------	-----------	--	--

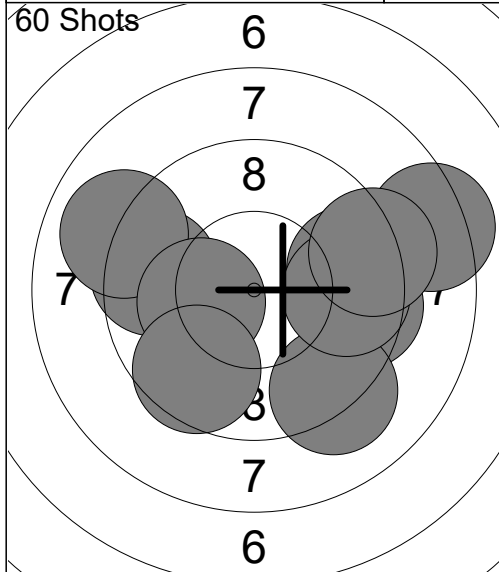

1:	9.5	←
2:	9.0	↖
3:	9.5	→
4:	9.6	→
5:	10.2x	←
6:	9.2	↘
7:	9.7	→
8:	9.6	↘
9:	8.3	→
10:	9.2	→
Series	93.8	
	93.8	

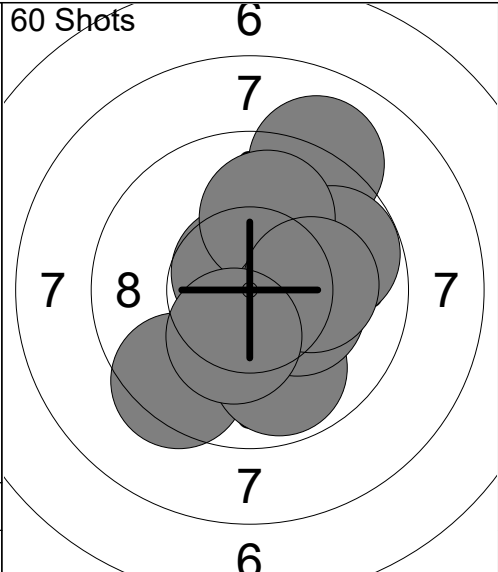

11:	10.6x	↗
12:	9.1	↗
13:	9.8	→
14:	10.7x	↖
15:	10.0	↑
16:	9.4	↙
17:	9.8	↘
18:	10.3x	→
19:	10.1	→
20:	10.3x	↘
Series	100.1	
	193.9	

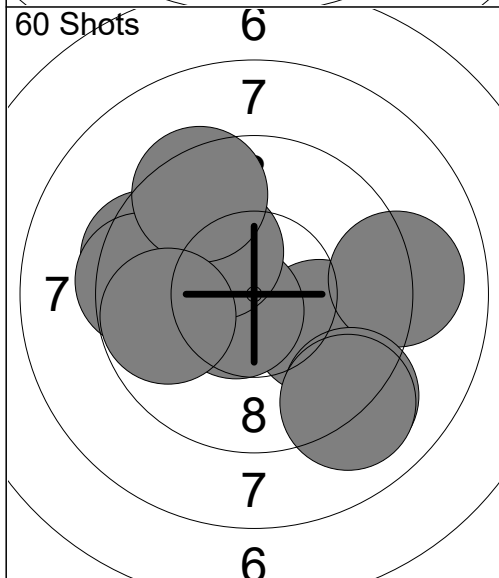

21:	9.5	←
22:	10.0	→
23:	9.1	→
24:	10.6x	↙
25:	10.2x	↗
26:	9.1	↘
27:	9.5	←
28:	9.4	↗
29:	9.8	←
30:	9.1	↘
Series	96.3	
	290.2	

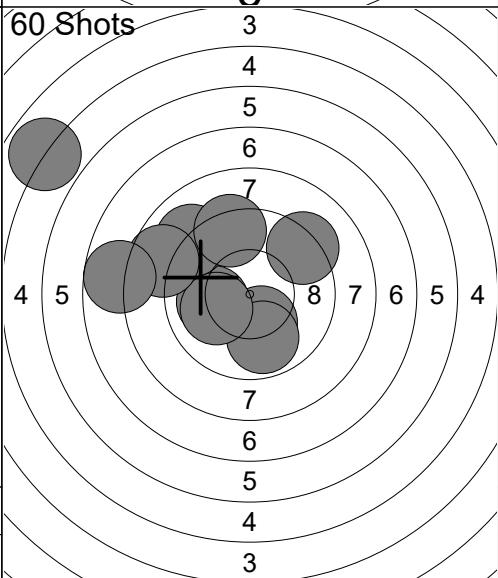

31:	10.0	←
32:	10.2x	↘
33:	9.8	↘
34:	4.9	↖
35:	9.2	↗
36:	10.1	←
37:	9.0	↖
38:	9.3	↑
39:	8.7	←
40:	7.7	←
Series	88.9	
	379.1	

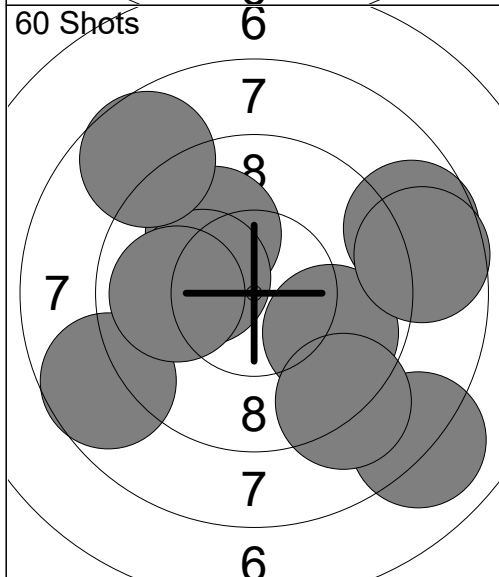

41:	10.0	↗
42:	10.2x	←
43:	8.7	→
44:	8.7	↖
45:	8.0	↘
46:	9.9	←
47:	9.8	↘
48:	8.7	→
49:	8.7	↗
50:	9.1	↘
Series	91.8	
	470.9	

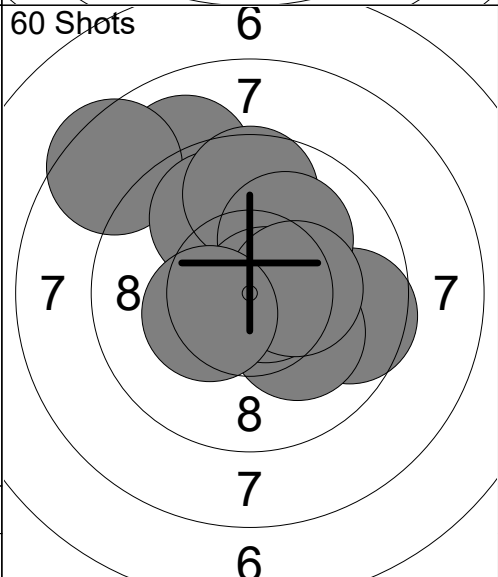

51:	9.6	→
52:	9.0	↗
53:	8.5	↖
54:	9.9	↑
55:	9.6	↑
56:	10.1	↘
57:	10.1	↗
58:	10.7x	→
59:	10.3x	→
60:	10.4x	↖
Series	98.2	
	569.1	

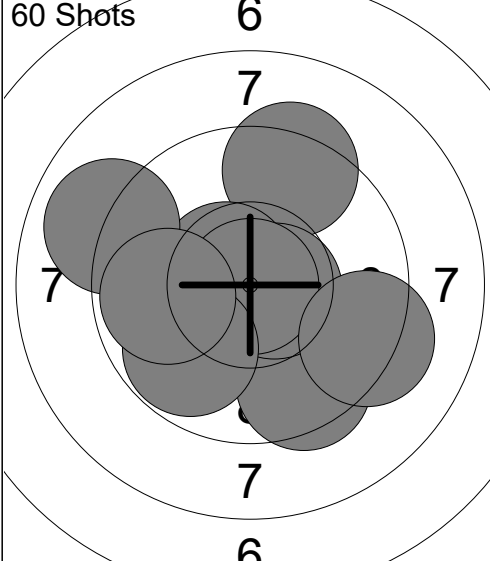
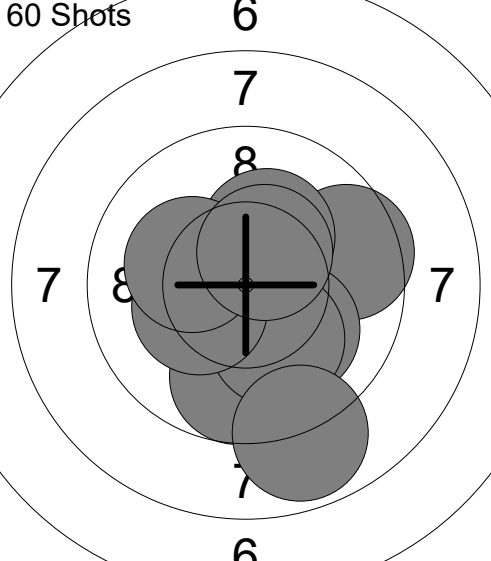
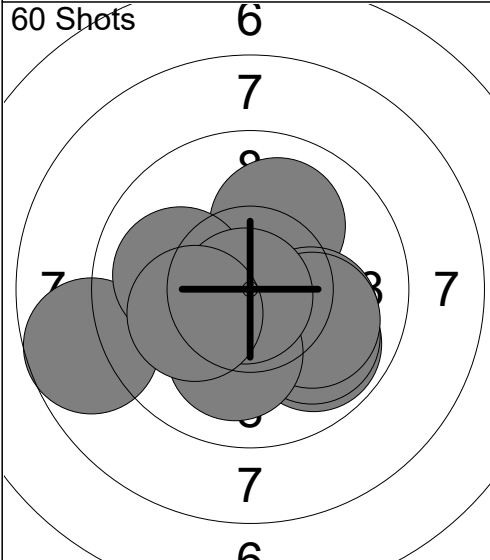
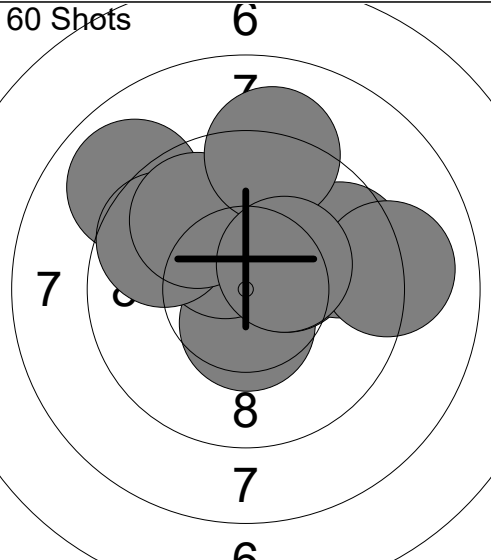
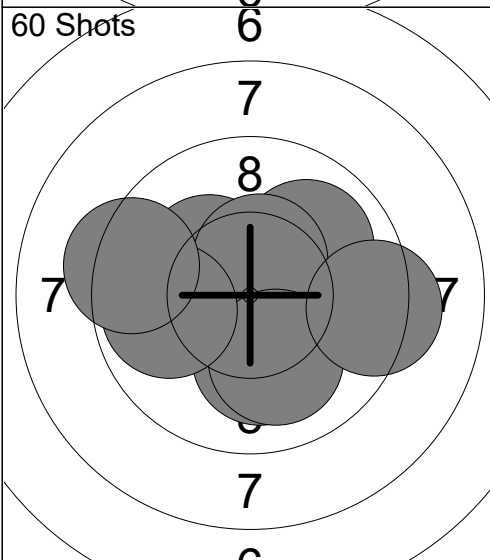
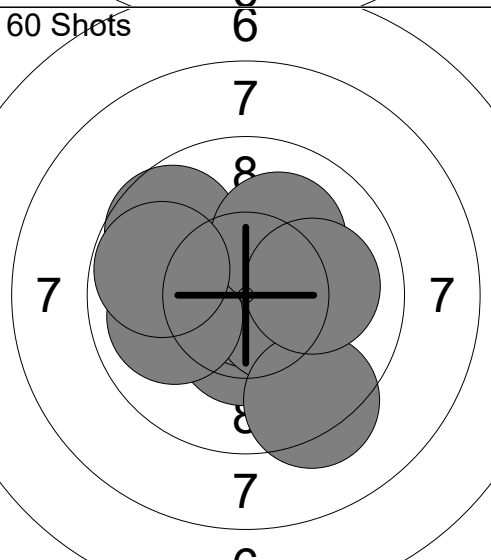
<p>60 Shots 6</p>  <p style="text-align: center;">6</p>	<p>1: 9.3 ↗ 2: 9.5 ↘ 3: 10.3x ↙ 4: 10.6x → 5: 10.6x ↖ 6: 10.9x ↘ 7: 9.8 ↘ 8: 9.0 ↖ 9: 9.8 ← 10: 9.3 →</p> <p>Series 99.1</p> <p style="text-align: center;">99.1</p>	<p>60 Shots 6</p>  <p style="text-align: center;">6</p>	<p>11: 10.6x ↙ 12: 9.6 → 13: 9.7 ↘ 14: 10.1 ↘ 15: 10.1 ↘ 16: 8.9 ↘ 17: 10.2x ↗ 18: 10.3x ↙ 19: 10.2x ↙ 20: 10.5x ↗</p> <p>Series 100.2</p> <p style="text-align: center;">199.3</p>
<p>60 Shots 6</p>  <p style="text-align: center;">6</p>	<p>21: 9.8 ↘ 22: 10.0 ↗ 23: 8.7 ← 24: 10.1 → 25: 9.9 ↘ 26: 10.0 → 27: 10.1 ↘ 28: 10.0 ← 29: 10.8x ↘ 30: 10.2x ↙</p> <p>Series 99.6</p> <p style="text-align: center;">298.9</p>	<p>60 Shots 6</p>  <p style="text-align: center;">6</p>	<p>31: 9.0 ↖ 32: 10.5x ↘ 33: 10.4x ↗ 34: 9.7 ↖ 35: 10.3x ↗ 36: 9.8 ↖ 37: 9.6 → 38: 9.1 ↗ 39: 9.1 → 40: 10.3x ↗</p> <p>Series 97.8</p> <p style="text-align: center;">396.7</p>
<p>60 Shots 6</p>  <p style="text-align: center;">6</p>	<p>41: 10.6x ↘ 42: 10.3x ↖ 43: 10.6x ↘ 44: 10.1 ↘ 45: 10.0 ↗ 46: 10.5x ↗ 47: 10.1 ↘ 48: 9.3 → 49: 9.9 ← 50: 9.3 ←</p> <p>Series 100.7</p> <p style="text-align: center;">497.4</p>	<p>60 Shots 6</p>  <p style="text-align: center;">6</p>	<p>51: 10.2x ↗ 52: 10.4x ↘ 53: 10.9x ↘ 54: 10.4x → 55: 9.7 ↖ 56: 9.3 ↘ 57: 10.0 ← 58: 10.1 ↗ 59: 9.8 ← 60: 10.1 →</p> <p>Series 100.9</p> <p style="text-align: center;">598.3</p>

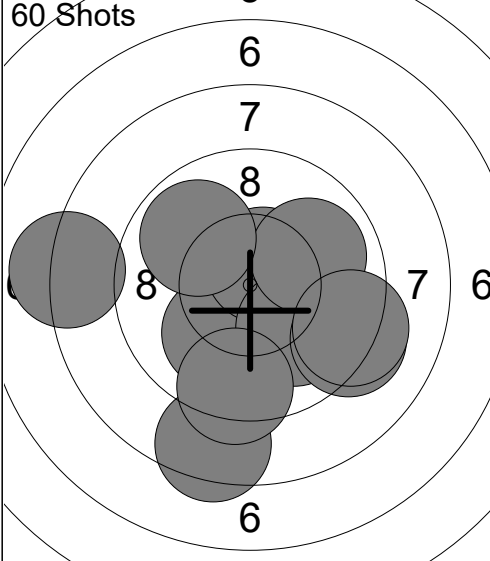
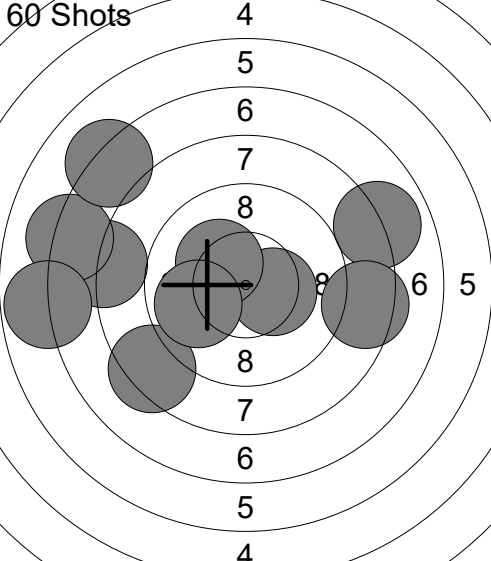
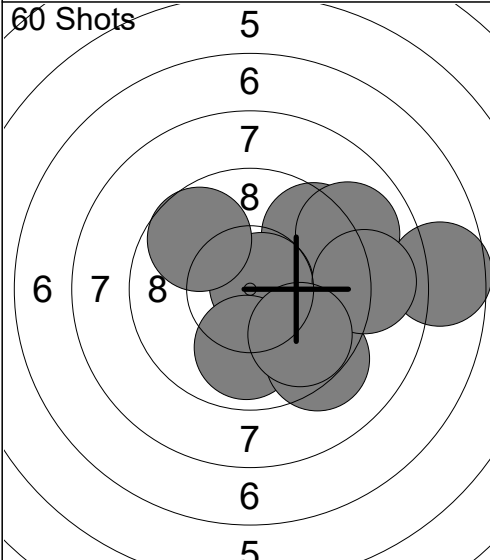
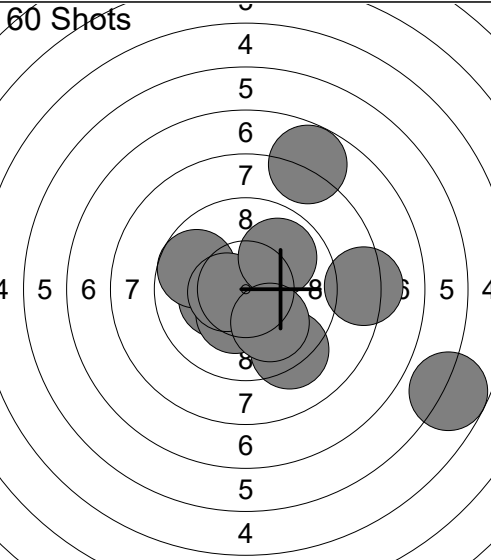
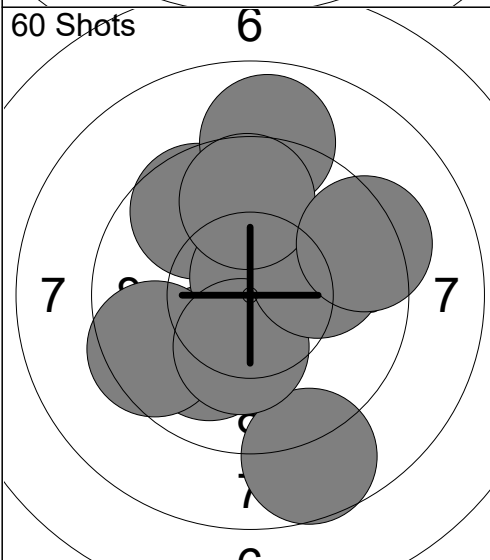
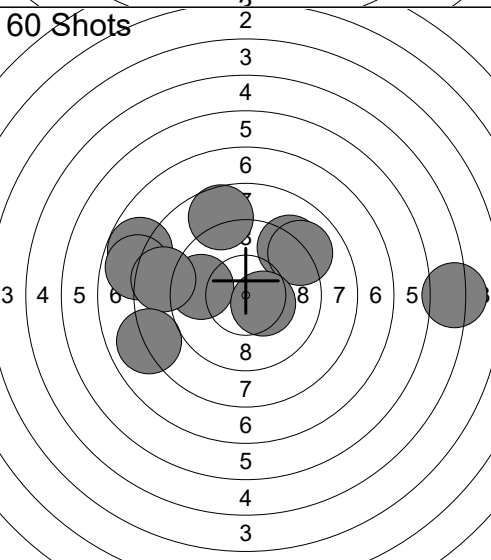
<p>60 Shots</p> 	<p>1: 10.1 ↘ 2: 10.6x ↗ 3: 8.4 ↓ 4: 10.0 ↘ 5: 9.2 → 6: 9.9 → 7: 9.4 ↓ 8: 8.1 ← 9: 9.9 ↗ 10: 9.3 →</p> <p>Series 94.9</p> <p style="text-align: center;">94.9</p>	<p>60 Shots</p> 	<p>11: 8.0 ← 12: 7.2 ← 13: 10.4x → 14: 8.3 ↙ 15: 6.8 ← 16: 8.0 → 17: 10.2x ↖ 18: 9.9 ← 19: 7.2 ↗ 20: 8.4 →</p> <p>Series 84.4</p> <p style="text-align: center;">179.3</p>
<p>60 Shots</p> 	<p>21: 9.5 ↗ 22: 9.9 → 23: 9.0 → 24: 10.7x → 25: 7.6 → 26: 9.9 ↓ 27: 9.3 ↘ 28: 9.0 → 29: 9.8 ↘ 30: 9.7 ↗</p> <p>Series 94.4</p> <p style="text-align: center;">273.7</p>	<p>60 Shots</p> 	<p>31: 10.3x ← 32: 7.8 ↗ 33: 10.3x ↘ 34: 9.7 ← 35: 10.5x ← 36: 9.9 ↗ 37: 9.2 ↘ 38: 8.2 → 39: 5.8 → 40: 10.0 ↘</p> <p>Series 91.7</p> <p style="text-align: center;">365.4</p>
<p>60 Shots</p> 	<p>41: 10.0 ↘ 42: 9.6 ↗ 43: 8.7 ↓ 44: 10.7x ↗ 45: 9.5 ← 46: 10.3x ↘ 47: 8.9 ↗ 48: 10.0 → 49: 9.7 ↗ 50: 9.3 →</p> <p>Series 96.7</p> <p style="text-align: center;">462.1</p>	<p>60 Shots</p> 	<p>51: 9.7 ← 52: 7.8 ← 53: 5.2 → 54: 9.2 ↗ 55: 9.0 ↗ 56: 7.9 ← 57: 8.7 ↗ 58: 8.6 ← 59: 8.0 ← 60: 10.4x →</p> <p>Series 84.5</p> <p style="text-align: center;">546.6</p>

Relay 6	Lane 37	FEY Bianca
-------------------	-------------------	-------------------

1-80	The X Count White	Precision	
------	-------------------	-----------	--

31.01.2025	2025 AirNats by X Count	Civilian Marksmanship Program	
------------	-------------------------	-------------------------------	--

Comment	Signature		
---------	-----------	--	--

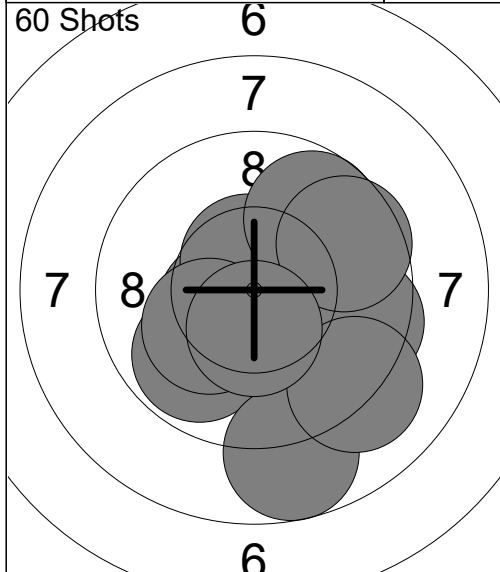

1:	10.5x	↙
2:	10.6x	↑
3:	9.8	↘
4:	10.2x	↙
5:	9.5	→
6:	8.7	↓
7:	9.7	↗
8:	9.6	↗
9:	9.1	↘
10:	10.4x	↓
Series		98.1
		98.1

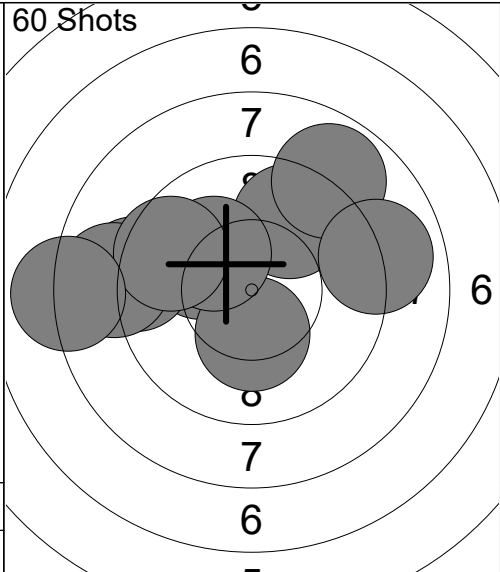

11:	9.7	↗
12:	10.1	↖
13:	9.1	←
14:	8.9	↗
15:	8.8	←
16:	8.9	→
17:	10.3x	↓
18:	10.1	↖
19:	9.6	↖
20:	8.1	←
Series		93.6
		191.7

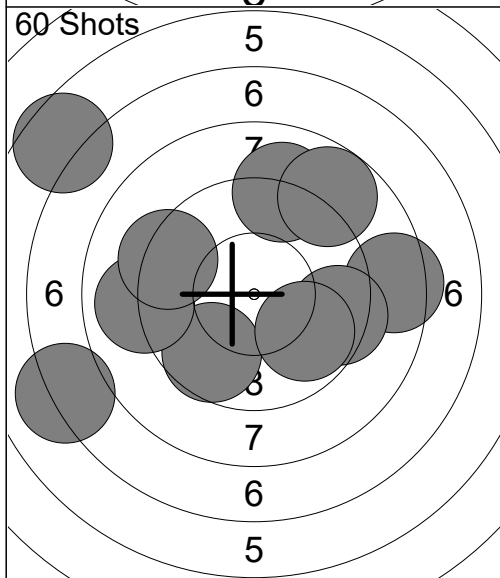

21:	9.0	↑
22:	9.7	↘
23:	8.8	↗
24:	8.4	→
25:	9.0	←
26:	6.6	↗
27:	9.4	→
28:	7.1	←
29:	9.3	↖
30:	9.8	↘
Series		87.1
		278.8

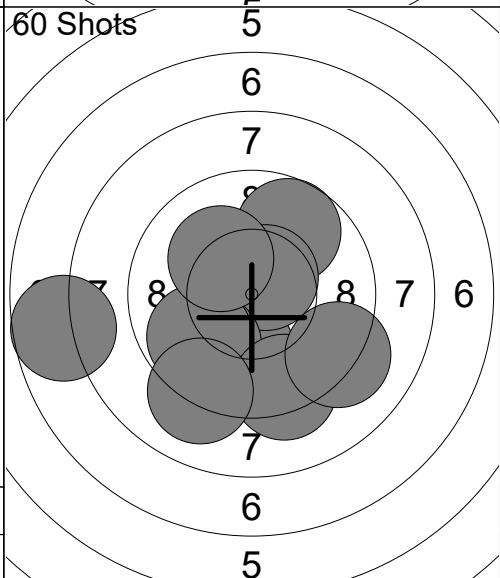

31:	9.7	↗
32:	10.0	↓
33:	10.6x	↗
34:	9.8	↘
35:	9.8	↘
36:	9.3	↓
37:	9.2	↘
38:	9.1	↘
39:	7.7	←
40:	10.1	↖
Series		95.3
		374.1

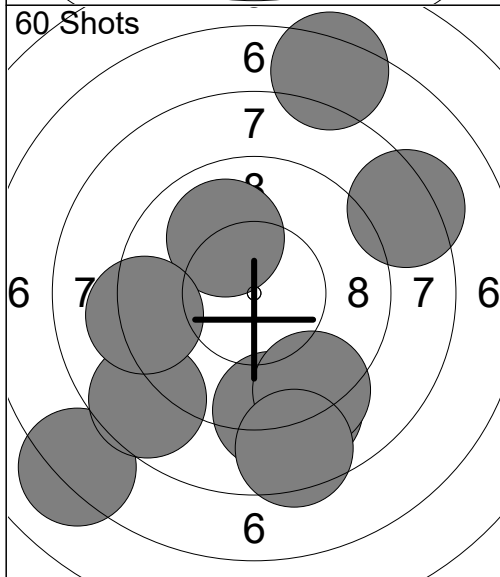

41:	9.0	↓
42:	10.0	↗
43:	9.1	↓
44:	7.1	↘
45:	8.6	↘
46:	9.2	←
47:	7.3	↑
48:	8.3	↗
49:	9.2	↘
50:	8.5	↓
Series		86.3
		460.4

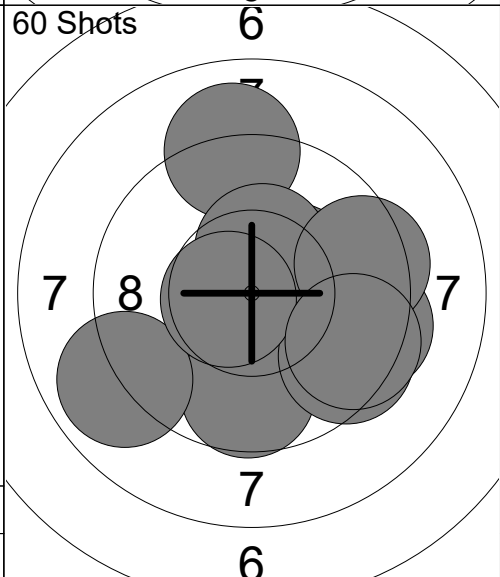

51:	10.3x	↗
52:	9.0	↑
53:	9.7	↓
54:	9.4	→
55:	8.9	↘
56:	10.4x	↑
57:	9.4	→
58:	9.5	↘
59:	10.6x	←
60:	9.5	↘
Series		96.7
		557.1

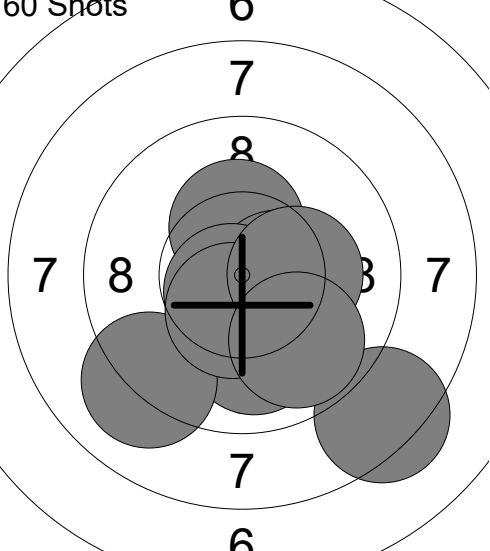
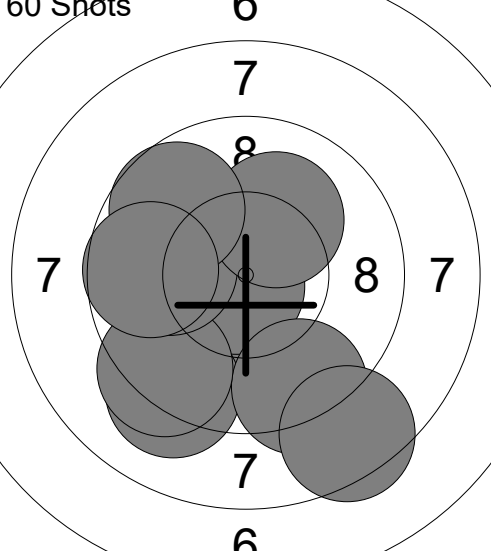
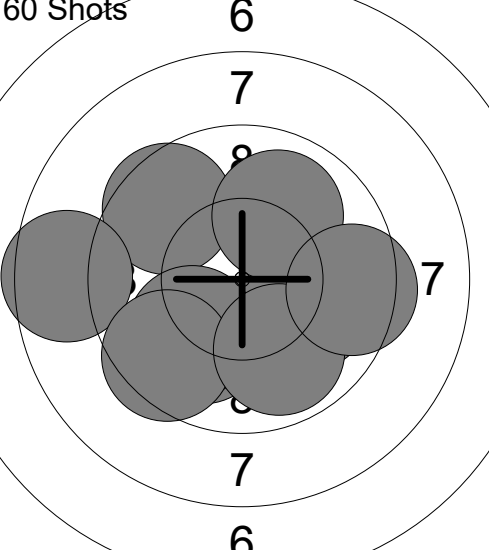
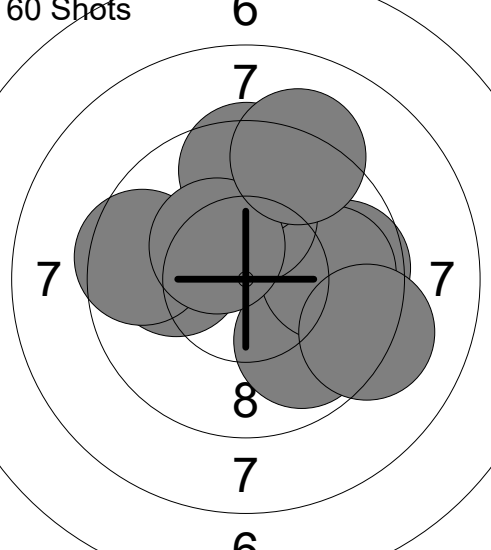
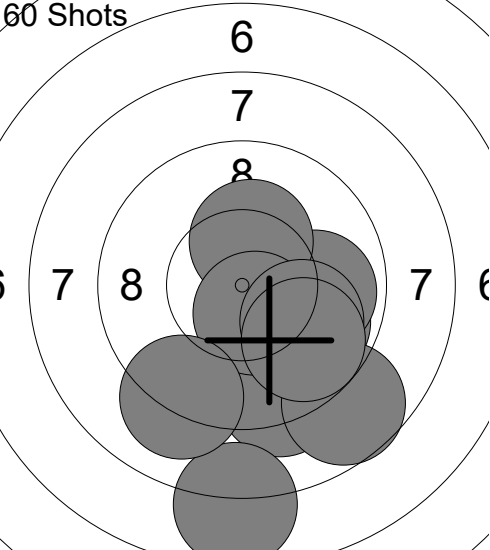
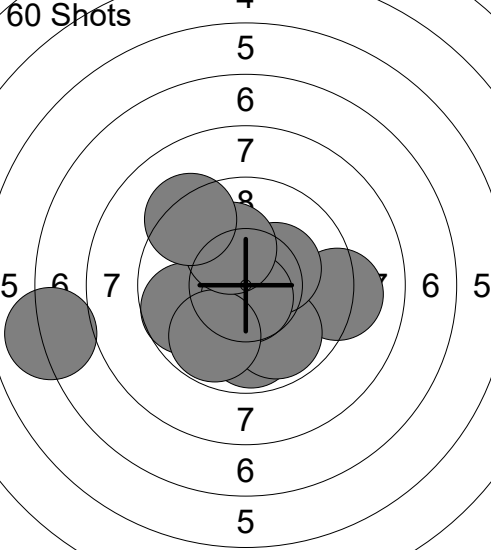
<p>60 Shots</p>  <p style="text-align: center;">6 7 8 7 8 7 7 7</p> <p style="text-align: center;">Series 99.7 99.7</p>	<p>1: 10.0 ↓ 2: 10.3x ↑ 3: 8.3 ↓ 4: 10.2x ↓ 5: 9.1 ↓ 6: 10.5x → 7: 10.7x ↓ 8: 10.5x ↓ 9: 10.3x → 10: 9.8 ↓</p> <p style="text-align: center;">Series 99.7 99.7</p>	<p>60 Shots</p>  <p style="text-align: center;">6 7 8 7 8 7 7 7</p> <p style="text-align: center;">Series 96.2 195.9</p>	<p>11: 9.7 ↙ 12: 9.2 ↙ 13: 10.8x ↙ 14: 9.3 ↓ 15: 8.5 ↓ 16: 9.3 ↙ 17: 9.9 ← 18: 10.1 ↗ 19: 9.7 ↗ 20: 9.7 ←</p> <p style="text-align: center;">Series 96.2 195.9</p>
<p>60 Shots</p>  <p style="text-align: center;">6 6 7 8 7 7 7 7</p> <p style="text-align: center;">Series 97.1 293.0</p>	<p>21: 9.6 ↗ 22: 10.0 → 23: 10.0 ↓ 24: 8.6 ← 25: 10.1 ↓ 26: 10.0 ↗ 27: 10.0 ↓ 28: 9.5 ↓ 29: 9.9 ↓ 30: 9.4 →</p> <p style="text-align: center;">Series 97.1 293.0</p>	<p>60 Shots</p>  <p style="text-align: center;">6 6 7 8 7 7 7 7</p> <p style="text-align: center;">Series 97.4 390.4</p>	<p>31: 9.9 ↓ 32: 9.7 → 33: 9.9 → 34: 10.0 ← 35: 10.1 ↑ 36: 9.2 → 37: 9.5 ↑ 38: 9.5 ← 39: 10.4x ↗ 40: 9.2 ↗</p> <p style="text-align: center;">Series 97.4 390.4</p>
<p>60 Shots</p>  <p style="text-align: center;">6 6 7 8 7 8 7 7 7</p> <p style="text-align: center;">Series 95.1 485.5</p>	<p>41: 9.8 → 42: 9.9 → 43: 10.3x ↑ 44: 9.3 ↓ 45: 10.5x ↓ 46: 9.9 → 47: 8.7 ↓ 48: 7.8 ↓ 49: 9.1 ↓ 50: 9.8 ↓</p> <p style="text-align: center;">Series 95.1 485.5</p>	<p>60 Shots</p>  <p style="text-align: center;">6 5 6 7 8 7 6 5 7 6 5 7 6 5</p> <p style="text-align: center;">Series 95.9 581.4</p>	<p>51: 7.0 ← 52: 9.7 ← 53: 9.8 ↓ 54: 9.2 → 55: 9.9 ↓ 56: 10.3x ↗ 57: 10.7x ↓ 58: 9.8 ↓ 59: 10.2x ↑ 60: 9.3 ↗</p> <p style="text-align: center;">Series 95.9 581.4</p>

Comment	Signature
---------	-----------

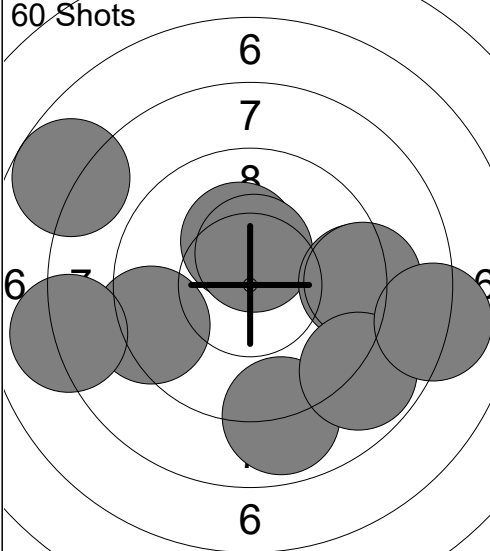
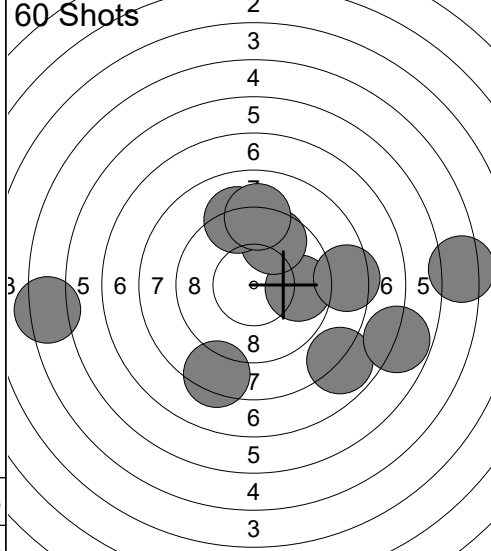
<p>60 Shots</p> 	<p>1: 8.9 ↓ 2: 10.3x ↑ 3: 10.5x ↑ 4: 9.3 ← 5: 9.3 → 6: 9.2 → 7: 8.8 ↓ 8: 8.1 ← 9: 7.8 ↗ 10: 8.1 →</p> <p>Series 90.3 90.3</p>	<p>60 Shots</p> 	<p>11: 7.9 ↘ 12: 9.7 → 13: 9.6 ↗ 14: 8.3 ↓ 15: 9.1 ↑ 16: 5.3 ← 17: 5.3 → 18: 8.4 → 19: 6.8 ↘ 20: 9.1 ↑</p> <p>Series 79.5 169.8</p>
--	---	--	---

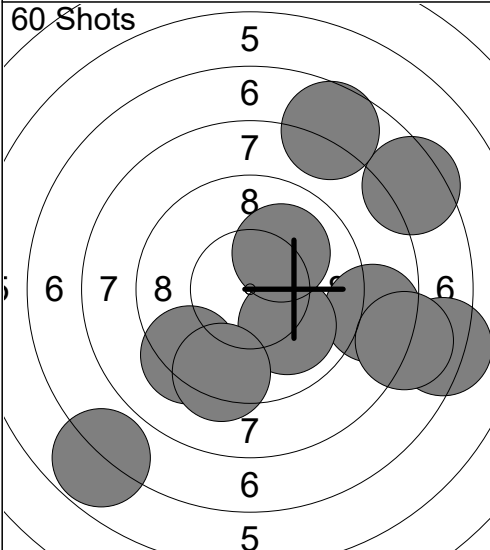
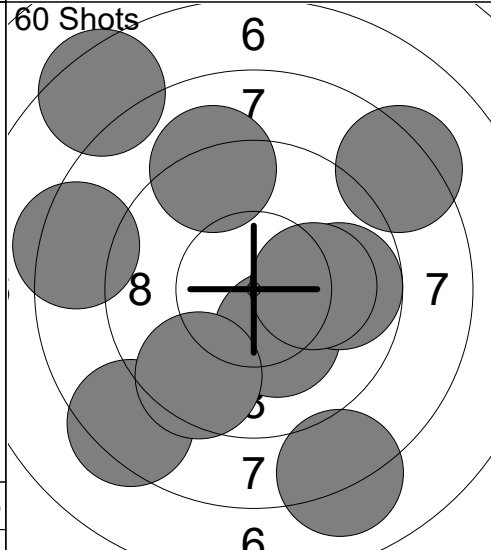
<p>60 Shots</p> 	<p>21: 8.7 → 22: 7.3 → 23: 8.0 → 24: 7.4 ↗ 25: 10.0 ↓ 26: 7.7 ↑ 27: 6.8 ↓ 28: 10.1 ↗ 29: 9.3 ↓ 30: 9.3 ↓</p> <p>Series 84.6 254.4</p>	<p>60 Shots</p> 	<p>31: 8.4 ↘ 32: 10.2x ↓ 33: 8.3 ↗ 34: 9.5 ↓ 35: 8.4 ← 36: 9.7 → 37: 7.4 ↗ 38: 9.2 ↑ 39: 10.1 → 40: 8.1 ↓</p> <p>Series 89.3 343.7</p>
---	---	---	--

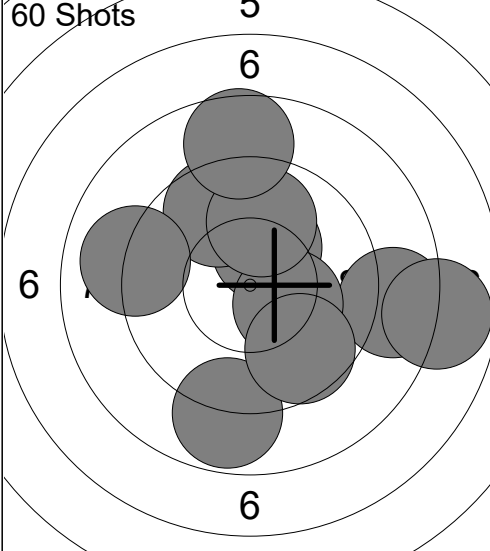
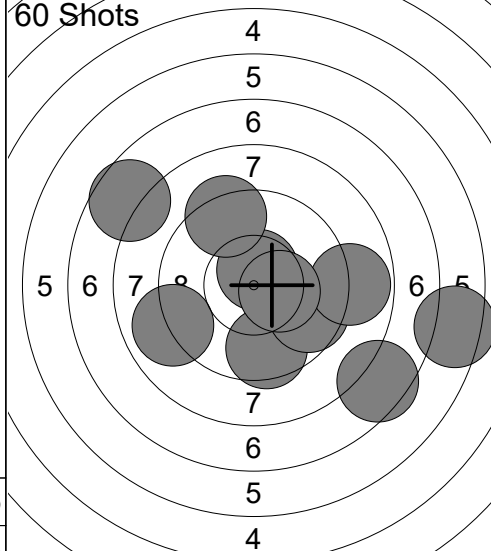
<p>60 Shots</p> 	<p>41: 8.6 → 42: 8.8 ↓ 43: 10.3x ↑ 44: 10.3x → 45: 9.6 ↑ 46: 9.0 ← 47: 9.6 ↓ 48: 9.9 ↑ 49: 7.9 → 50: 8.6 ↑</p> <p>Series 92.6 436.3</p>	<p>60 Shots</p> 	<p>51: 9.5 ↓ 52: 7.5 ↘ 53: 6.4 → 54: 10.6x ↑ 55: 9.6 → 56: 9.3 ↑ 57: 9.0 ← 58: 8.8 → 59: 10.4x → 60: 7.6 ←</p> <p>Series 88.7 525.0</p>
--	---	--	---

Relay 6	Lane 41	GOIN Hannah	
1-80	Walla Walla HS AJROTC	Precision	
31.01.2025	2025 AirNats by X Count	Civilian Marksmanship Program	
Comment	Signature		

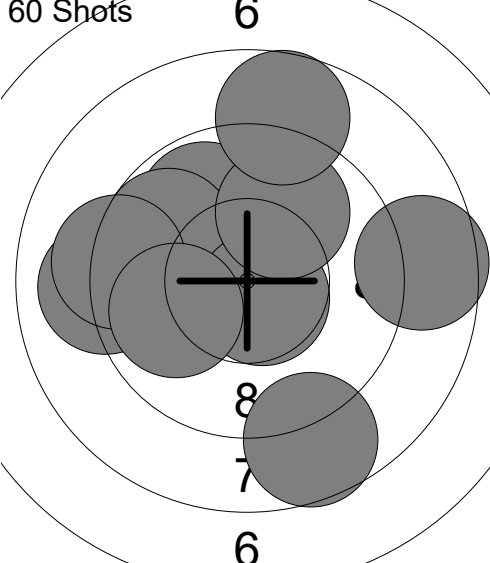
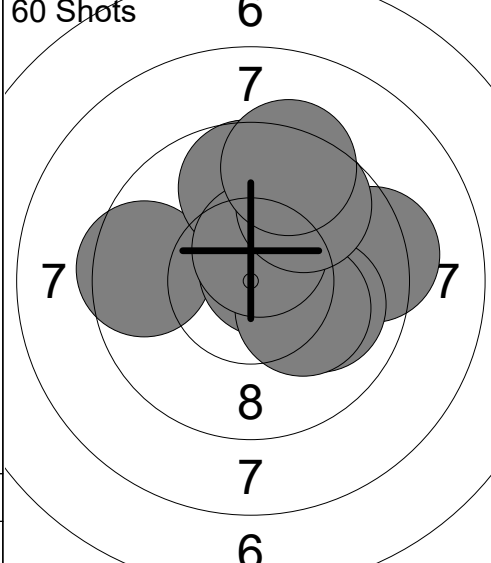
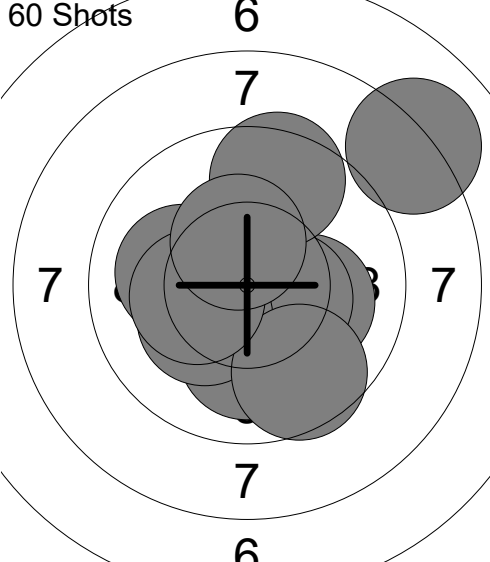
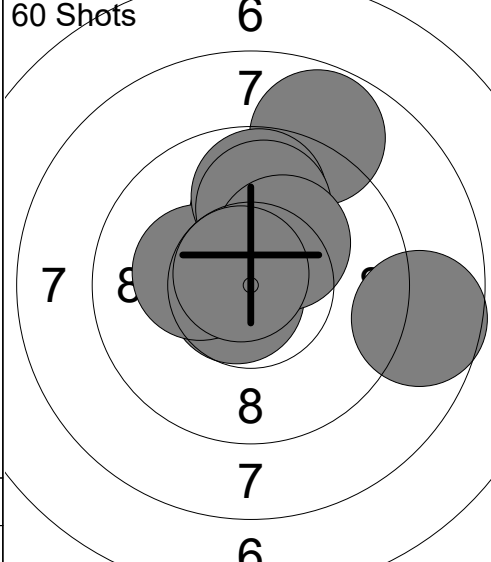
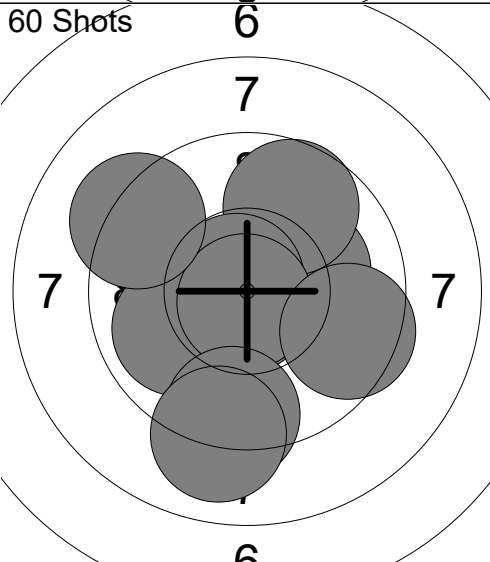
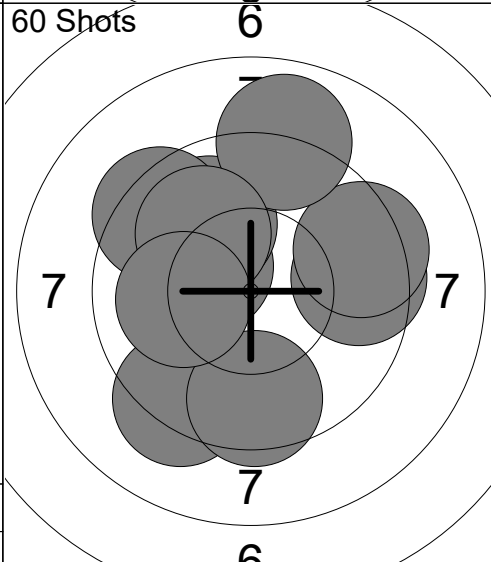
60 Shots 6 	1: 9.8 ↗ 2: 9.7 ↗ 3: 8.6 → 4: 8.7 ↓ 5: 9.0 ← 6: 10.6x ↓ 7: 9.2 ← 8: 9.9 ← 9: 9.9 ↗ 10: 8.7 ↗ Series 94.1 94.1	60 Shots 6 	11: 9.5 ← 12: 9.7 ↑ 13: 9.3 → 14: 10.7x ↗ 15: 9.7 ↑ 16: 10.0 → 17: 10.2x → 18: 10.5x ↑ 19: 9.7 ↗ 20: 9.4 ↗ Series 98.7 192.8
60 Shots 6 	21: 10.1 → 22: 10.1 ↓ 23: 10.1 ← 24: 10.4x → 25: 10.2x ↙ 26: 9.6 ↓ 27: 10.3x ← 28: 9.5 ↑ 29: 10.4x ↑ 30: 8.1 ↗ Series 98.8 291.6	60 Shots 6 	31: 10.0 ↑ 32: 10.7x ↑ 33: 10.7x ↙ 34: 10.3x ← 35: 8.8 ↗ 36: 9.8 ↑ 37: 9.9 ↑ 38: 8.7 → 39: 10.3x ↗ 40: 10.7x ↖ Series 99.9 391.5
60 Shots 6 	41: 10.2x → 42: 9.7 ↗ 43: 10.8x ↖ 44: 10.8x ↓ 45: 9.9 ← 46: 10.8x ↓ 47: 9.5 → 48: 9.3 ↓ 49: 9.2 ↖ 50: 9.0 ↓ Series 99.2 490.7	60 Shots 6 	51: 10.3x ↖ 52: 9.2 ↙ 53: 9.5 → 54: 9.4 → 55: 9.9 ↗ 56: 9.4 ↖ 57: 9.5 ↓ 58: 8.9 ↑ 59: 10.0 ↖ 60: 10.0 ← Series 96.1 586.8

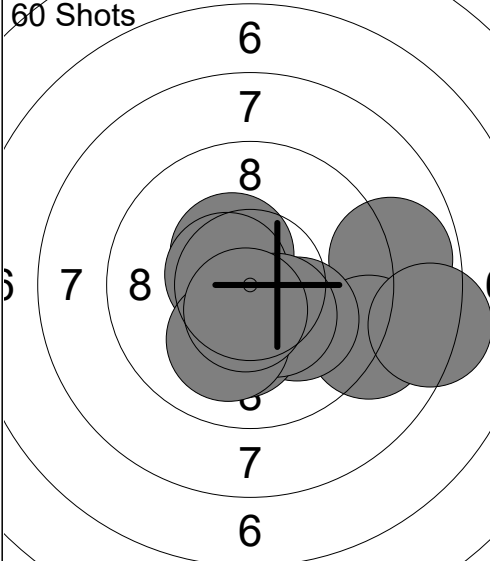
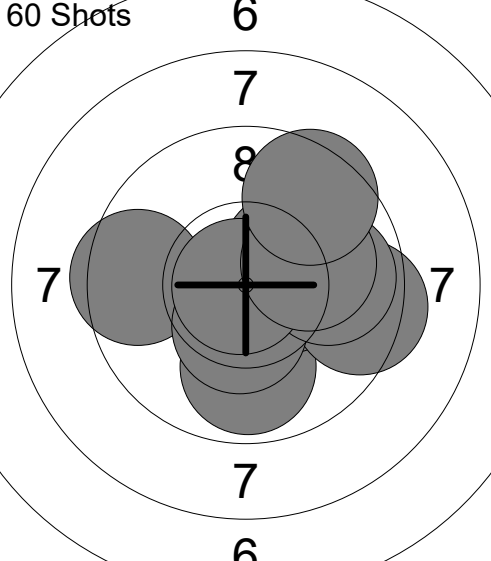
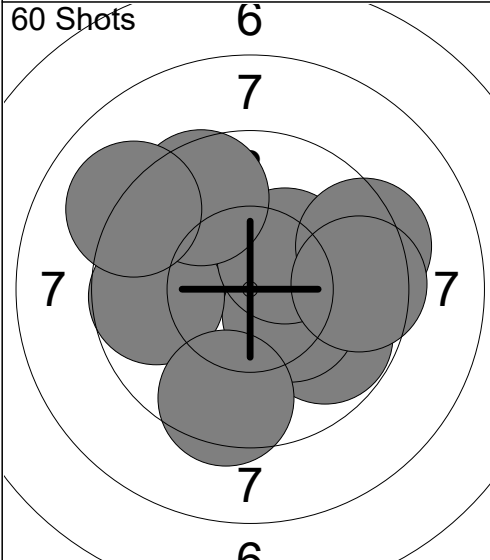
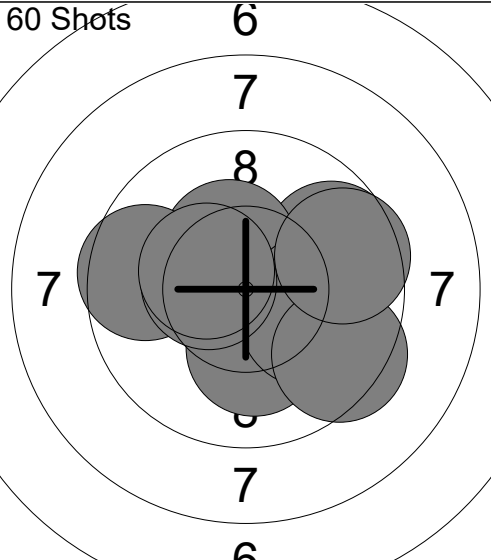
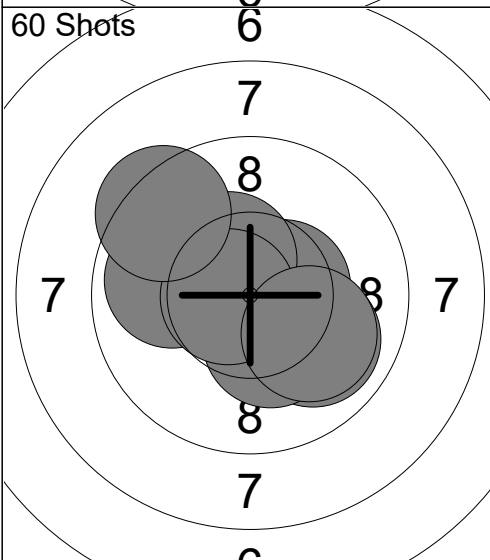
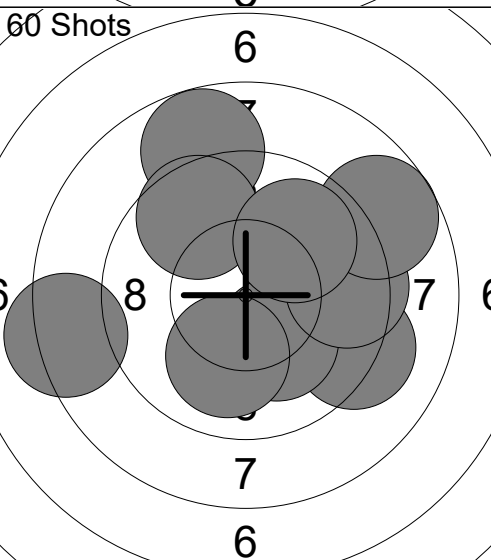
<p>60 Shots</p>  <p style="text-align: center;">6 7 8 7 6</p>	<p>1: 8.9 →</p> <p>2: 10.4x ↗</p> <p>3: 10.6x ↖</p> <p>4: 9.1 →</p> <p>5: 10.1 ↘</p> <p>6: 10.2x ↓</p> <p>7: 10.4x ↓</p> <p>8: 10.1 ↓</p> <p>9: 8.3 →</p> <p>10: 10.6x ↓</p> <hr/> <p>Series 98.7</p> <p style="text-align: center;">98.7</p>	<p>60 Shots</p>  <p style="text-align: center;">6 7 8 7</p>	<p>11: 9.9 ↓</p> <p>12: 10.4x →</p> <p>13: 9.4 →</p> <p>14: 9.5 ←</p> <p>15: 10.4x ↓</p> <p>16: 9.9 →</p> <p>17: 10.3x ↗</p> <p>18: 10.9x ←</p> <p>19: 10.1 →</p> <p>20: 9.5 ↗</p> <hr/> <p>Series 100.3</p> <p style="text-align: center;">199.0</p>
<p>60 Shots</p>  <p style="text-align: center;">6 7 7</p>	<p>21: 9.8 ↘</p> <p>22: 10.4x ↗</p> <p>23: 10.3x ↘</p> <p>24: 9.7 ←</p> <p>25: 10.3x ↗</p> <p>26: 9.6 ↗</p> <p>27: 9.1 ↗</p> <p>28: 9.5 ↓</p> <p>29: 9.3 →</p> <p>30: 9.5 →</p> <hr/> <p>Series 97.5</p> <p style="text-align: center;">296.5</p>	<p>60 Shots</p>  <p style="text-align: center;">6 7 8 7</p>	<p>31: 9.7 ↗</p> <p>32: 10.4x ↗</p> <p>33: 10.0 →</p> <p>34: 9.6 ←</p> <p>35: 10.2x ↓</p> <p>36: 10.0 ↘</p> <p>37: 9.4 ↘</p> <p>38: 9.6 →</p> <p>39: 10.5x ←</p> <p>40: 10.4x ↖</p> <hr/> <p>Series 99.8</p> <p style="text-align: center;">396.3</p>
<p>60 Shots</p>  <p style="text-align: center;">6 7 8 7 6</p>	<p>41: 9.9 ↘</p> <p>42: 10.8x ←</p> <p>43: 9.9 ←</p> <p>44: 10.6x ↘</p> <p>45: 10.5x →</p> <p>46: 10.4x ↗</p> <p>47: 10.3x ↓</p> <p>48: 10.7x ←</p> <p>49: 9.4 ↗</p> <p>50: 10.0 ↘</p> <hr/> <p>Series 102.5</p> <p style="text-align: center;">498.8</p>	<p>60 Shots</p>  <p style="text-align: center;">6 7 8 7 6</p>	<p>51: 10.1 →</p> <p>52: 8.8 ↗</p> <p>53: 8.3 ←</p> <p>54: 9.6 ↗</p> <p>55: 9.2 ↘</p> <p>56: 10.2x ↓</p> <p>57: 9.5 →</p> <p>58: 10.0 ↓</p> <p>59: 8.7 ↗</p> <p>60: 9.9 ↗</p> <hr/> <p>Series 94.3</p> <p style="text-align: center;">593.1</p>

Relay 6	Lane 43	NELSON Sarah
--------------------------	--------------------------	---------------------

1-80	Walla Walla HS AJROTC	Precision	
------	-----------------------	-----------	--

31.01.2025	2025 AirNats by X Count	Civilian Marksmanship Program
------------	-------------------------	-------------------------------

Comment	Signature
---------	-----------

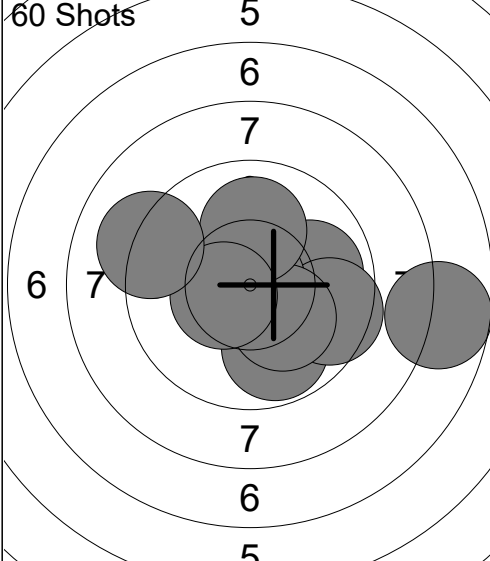
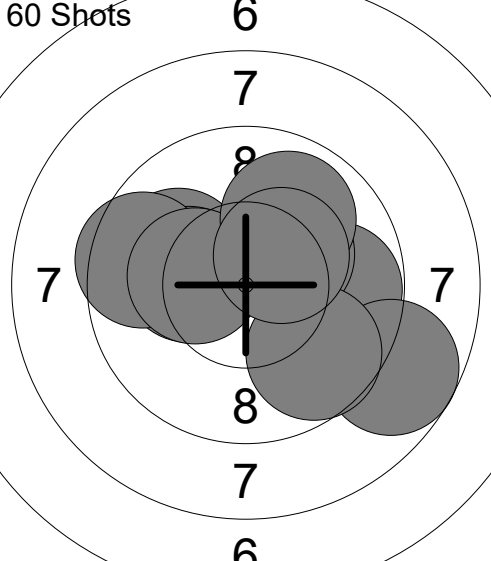
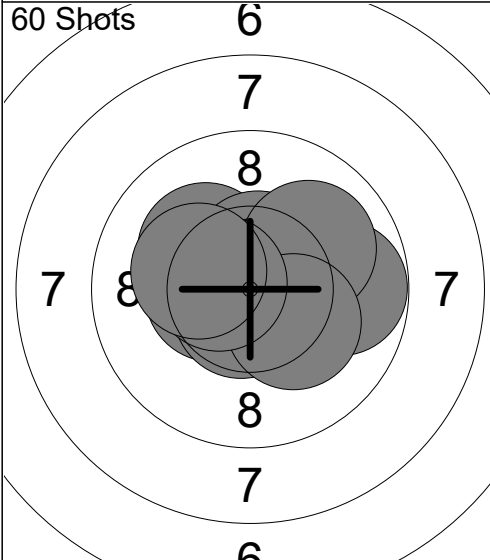
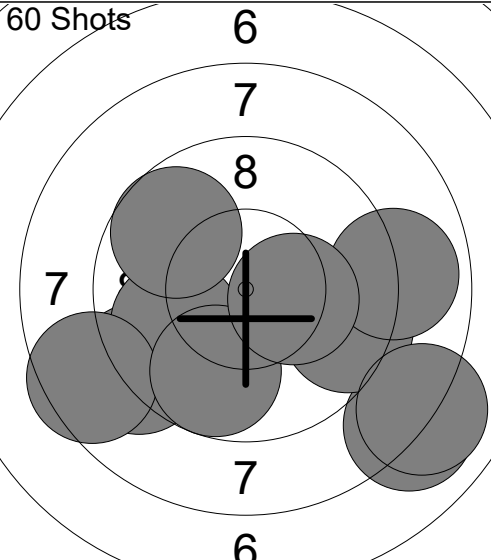
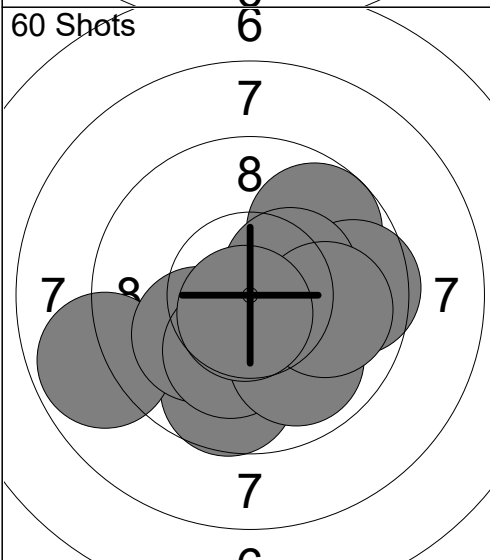
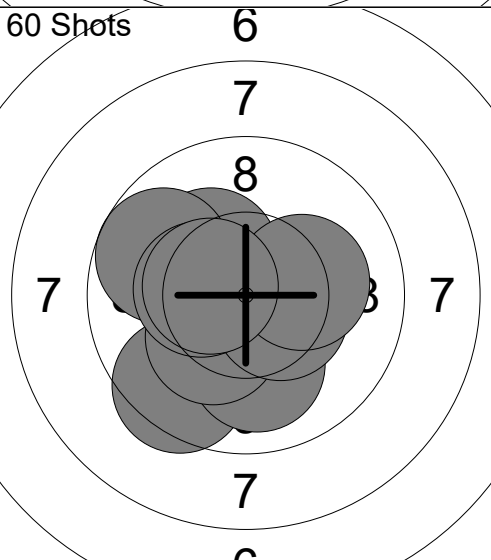
<p>60 Shots</p>  <p style="text-align: center;">5 6 7 6 7 6</p>	<p>1: 10.5x →</p> <p>2: 9.9 →</p> <p>3: 9.8 ↓</p> <p>4: 9.5 →</p> <p>5: 10.9x ↗</p> <p>6: 10.2x ↘</p> <p>7: 10.0 ↑</p> <p>8: 10.5x ←</p> <p>9: 9.1 ←</p> <p>10: 7.7 →</p> <hr/> <p>Series 98.1</p> <hr/> <p style="text-align: right;">98.1</p>	<p>60 Shots</p>  <p style="text-align: center;">6 7 8 7 8 7</p>	<p>11: 10.0 ←</p> <p>12: 10.2x ←</p> <p>13: 9.5 ←</p> <p>14: 9.8 →</p> <p>15: 10.3x ←</p> <p>16: 8.7 →</p> <p>17: 10.3x ↗</p> <p>18: 9.7 ↘</p> <p>19: 9.9 ↗</p> <p>20: 10.3x ↗</p> <hr/> <p>Series 98.7</p> <hr/> <p style="text-align: right;">196.8</p>
<p>60 Shots</p>  <p style="text-align: center;">5 6 7 8 7 8 7</p>	<p>21: 10.5x ←</p> <p>22: 10.2x ↖</p> <p>23: 10.7x ↓</p> <p>24: 10.5x ↗</p> <p>25: 10.7x →</p> <p>26: 9.8 →</p> <p>27: 10.0 ↗</p> <p>28: 10.2x ↘</p> <p>29: 10.5x ←</p> <p>30: 10.2x ←</p> <hr/> <p>Series 103.3</p> <hr/> <p style="text-align: right;">300.1</p>	<p>60 Shots</p>  <p style="text-align: center;">6 7 8 7 8 7</p>	<p>31: 9.1 ↖</p> <p>32: 8.0 ↘</p> <p>33: 9.5 →</p> <p>34: 8.9 →</p> <p>35: 9.9 ←</p> <p>36: 8.0 ↘</p> <p>37: 8.5 ←</p> <p>38: 9.8 ↓</p> <p>39: 10.3x →</p> <p>40: 9.7 ↖</p> <hr/> <p>Series 91.7</p> <hr/> <p style="text-align: right;">391.8</p>
<p>60 Shots</p>  <p style="text-align: center;">6 7 8 7 8 7 6</p>	<p>41: 9.8 ↗</p> <p>42: 9.6 →</p> <p>43: 10.4x →</p> <p>44: 9.7 ↓</p> <p>45: 8.8 ←</p> <p>46: 10.1 ↖</p> <p>47: 10.2x ↘</p> <p>48: 9.9 ↘</p> <p>49: 9.9 →</p> <p>50: 10.7x ↓</p> <hr/> <p>Series 99.1</p> <hr/> <p style="text-align: right;">490.9</p>	<p>60 Shots</p>  <p style="text-align: center;">6 7 8 7 8 7</p>	<p>51: 10.3x ↖</p> <p>52: 9.5 ↖</p> <p>53: 10.0 ↓</p> <p>54: 10.8x ↓</p> <p>55: 9.7 ↖</p> <p>56: 10.3x ↖</p> <p>57: 10.4x →</p> <p>58: 10.4x ←</p> <p>59: 10.2x →</p> <p>60: 10.5x ←</p> <hr/> <p>Series 102.1</p> <hr/> <p style="text-align: right;">593.0</p>

Relay 6	Lane 44	KAHEAKU Noah
-------------------	-------------------	---------------------

1-80	Walla Walla HS AJROTC	Precision	
------	-----------------------	-----------	--

31.01.2025	2025 AirNats by X Count	Civilian Marksmanship Program	
------------	-------------------------	-------------------------------	--

Comment	Signature		
---------	-----------	--	--

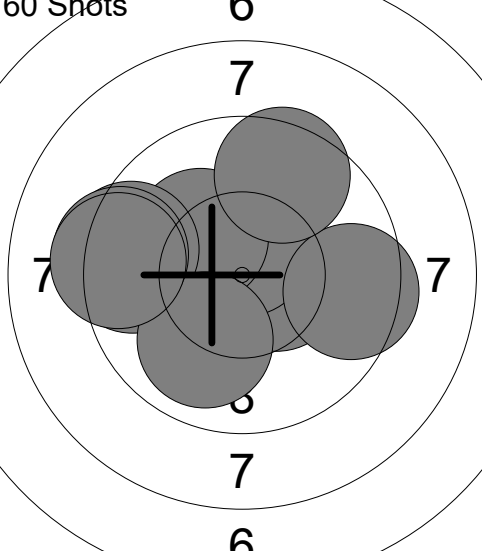
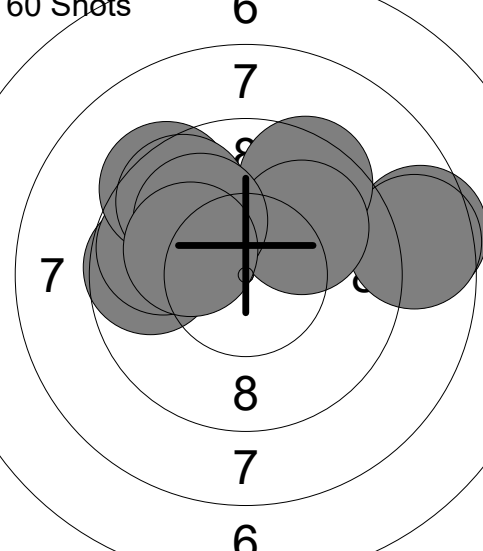
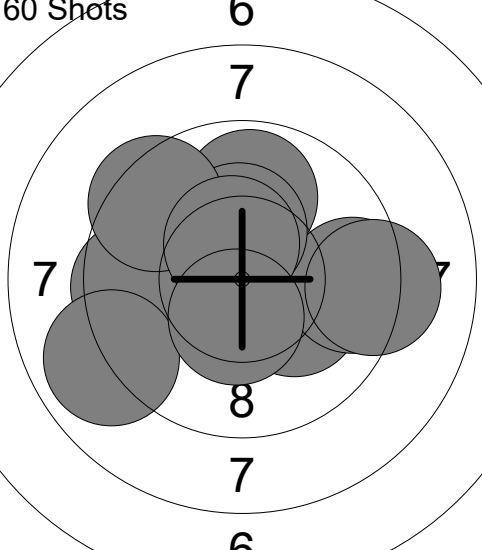
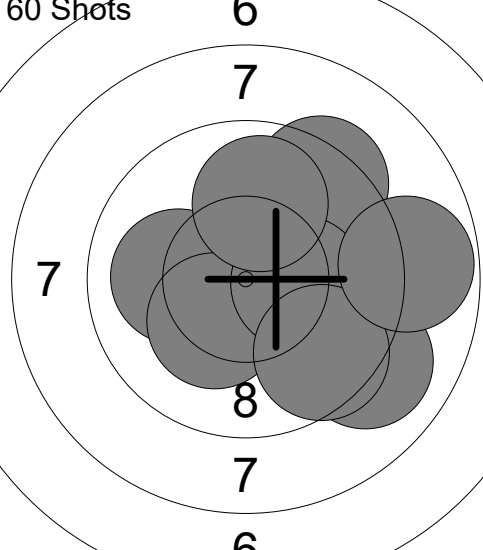
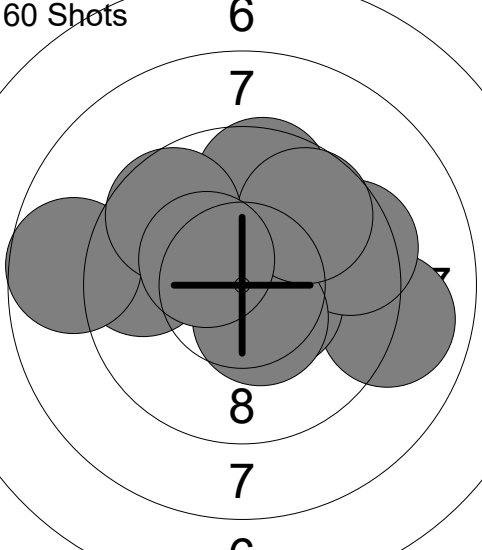
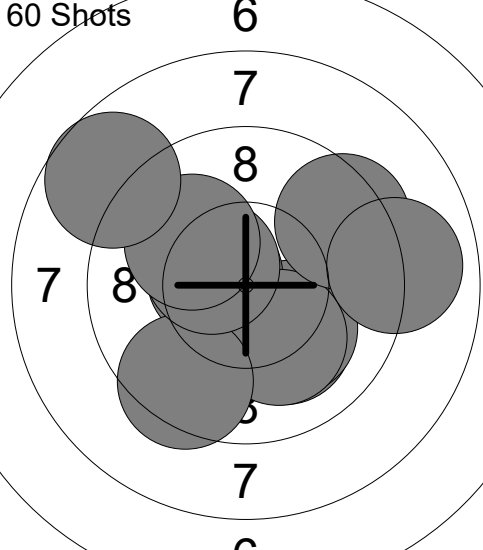
<p>60 Shots</p>  <p style="text-align: center;">6 7 7 7 7 7 7 7 7 7</p>	<p>1: 10.5x →</p> <p>2: 10.6x ↑</p> <p>3: 9.5 ←</p> <p>4: 9.5 →</p> <p>5: 10.2x ↗</p> <p>6: 9.4 ←</p> <p>7: 9.5 ↑</p> <p>8: 10.0 ↓</p> <p>9: 9.3 ←</p> <p>10: 9.3 ←</p> <hr/> <p>Series 97.8</p> <hr/> <p style="text-align: center;">97.8</p>	<p>60 Shots</p>  <p style="text-align: center;">6 7 7 7 7 7 7 7 7 7</p>	<p>11: 8.5 →</p> <p>12: 9.7 ←</p> <p>13: 9.8 ←</p> <p>14: 8.6 →</p> <p>15: 9.5 ↗</p> <p>16: 9.4 ↗</p> <p>17: 9.7 ↗</p> <p>18: 10.0 ↗</p> <p>19: 10.0 ↗</p> <p>20: 10.1 ←</p> <hr/> <p>Series 95.3</p> <hr/> <p style="text-align: center;">193.1</p>
<p>60 Shots</p>  <p style="text-align: center;">6 6 7 7 7 7 7 7 7 7</p>	<p>21: 9.6 ←</p> <p>22: 10.2x →</p> <p>23: 9.5 →</p> <p>24: 9.9 ↑</p> <p>25: 10.3x ↑</p> <p>26: 9.4 ↗</p> <p>27: 10.5x ↑</p> <p>28: 8.9 ←</p> <p>29: 9.2 →</p> <p>30: 10.4x ↓</p> <hr/> <p>Series 97.9</p> <hr/> <p style="text-align: center;">291.0</p>	<p>60 Shots</p>  <p style="text-align: center;">6 6 7 7 7 7 7 7 7 7</p>	<p>31: 9.5 →</p> <p>32: 9.8 ↗</p> <p>33: 10.1 ←</p> <p>34: 9.3 ↗</p> <p>35: 9.0 →</p> <p>36: 10.3x ↓</p> <p>37: 10.2x →</p> <p>38: 9.6 ↓</p> <p>39: 8.8 →</p> <p>40: 9.9 ↑</p> <hr/> <p>Series 96.5</p> <hr/> <p style="text-align: center;">387.5</p>
<p>60 Shots</p>  <p style="text-align: center;">6 6 7 7 7 7 7 7 7 7</p>	<p>41: 9.0 →</p> <p>42: 10.5x →</p> <p>43: 9.4 →</p> <p>44: 10.5x ↓</p> <p>45: 9.6 ↑</p> <p>46: 9.7 ↗</p> <p>47: 9.6 ←</p> <p>48: 8.7 ←</p> <p>49: 9.6 ↗</p> <p>50: 10.4x ↗</p> <hr/> <p>Series 97.0</p> <hr/> <p style="text-align: center;">484.5</p>	<p>60 Shots</p>  <p style="text-align: center;">6 6 7 7 7 7 7 7 7 7</p>	<p>51: 10.1 ↓</p> <p>52: 10.1 ↓</p> <p>53: 10.5x ←</p> <p>54: 10.1 ↓</p> <p>55: 9.4 ↓</p> <p>56: 9.4 ↗</p> <p>57: 10.4x ←</p> <p>58: 9.0 →</p> <p>59: 10.0 ↗</p> <p>60: 8.7 ←</p> <hr/> <p>Series 97.7</p> <hr/> <p style="text-align: center;">582.2</p>

Relay 6	Lane 45	EDWARDS Sofie
-------------------	-------------------	----------------------

1-80	Walla Walla HS AJROTC	Precision	
------	-----------------------	-----------	--

31.01.2025	2025 AirNats by X Count	Civilian Marksmanship Program	
------------	-------------------------	-------------------------------	--

Comment	Signature		
---------	-----------	--	--

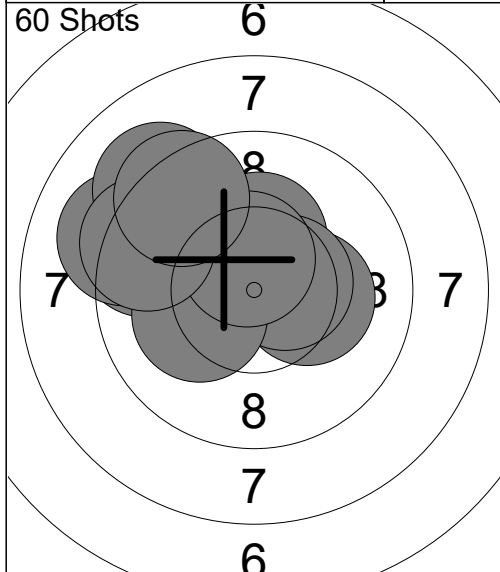

1:	10.3x	↑
2:	10.2x	→
3:	9.4	←
4:	10.5x	→
5:	9.1	←
6:	9.1	↗
7:	10.2x	↖
8:	10.5x	↑
9:	9.4	←
10:	9.4	↗
Series		98.1
		98.1

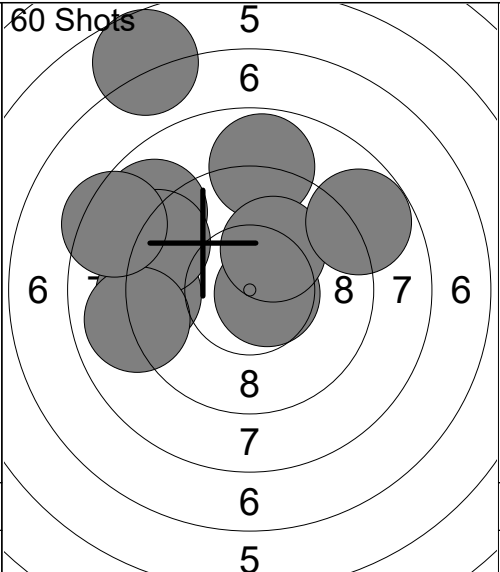

11:	8.9	↖
12:	10.6x	→
13:	6.7	↑
14:	9.2	←
15:	9.2	↖
16:	9.0	←
17:	8.8	↑
18:	10.2x	↗
19:	8.8	↗
20:	8.4	↖
Series		89.8
		187.9

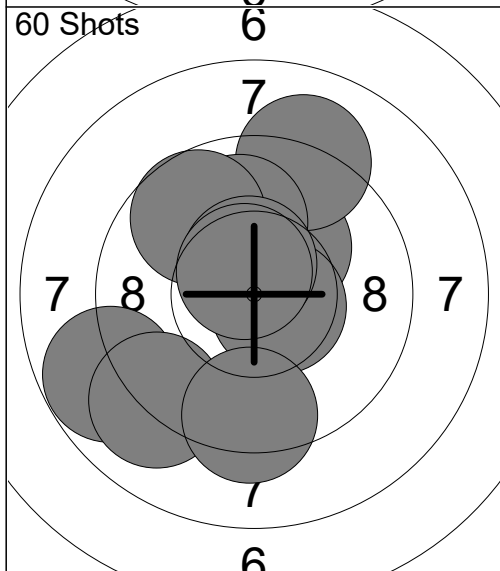

21:	10.2x	↗
22:	9.1	↑
23:	10.0	↑
24:	8.8	←
25:	9.7	↗
26:	10.6x	→
27:	9.0	↘
28:	10.5x	↑
29:	10.6x	↗
30:	9.3	↓
Series		97.8
		285.7

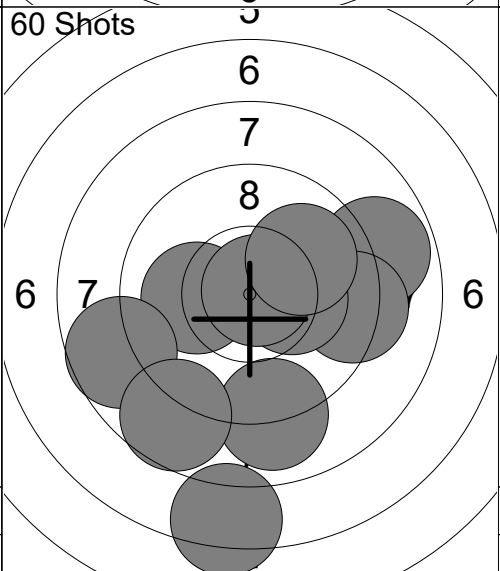

31:	10.1	←
32:	8.8	→
33:	8.7	←
34:	9.0	↓
35:	9.3	→
36:	8.7	↘
37:	7.3	↓
38:	10.3x	→
39:	10.8x	↗
40:	10.0	↗
Series		93.0
		378.7

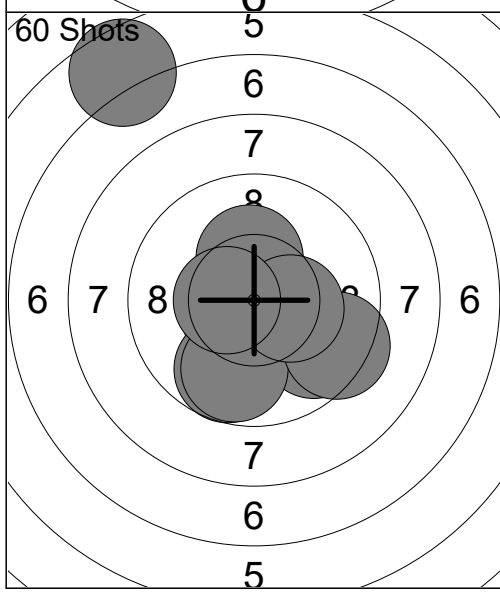

41:	9.7	↘
42:	10.9x	←
43:	10.5x	↘
44:	10.3x	↑
45:	9.7	↘
46:	9.8	↘
47:	9.4	↗
48:	6.6	↗
49:	10.3x	→
50:	10.5x	←
Series		97.7
		476.4

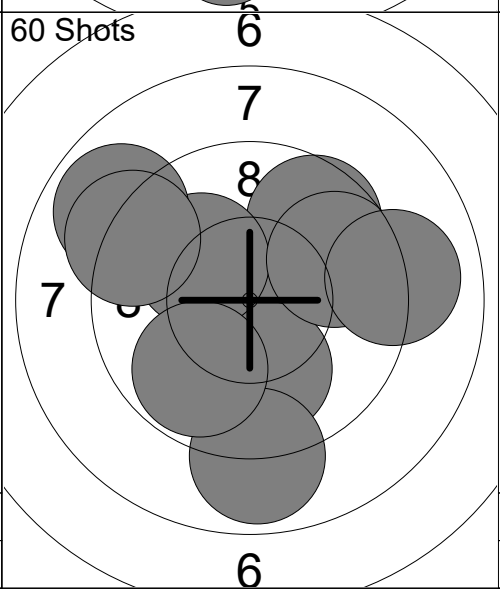

51:	10.7x	↗
52:	10.0	↓
53:	8.9	↓
54:	9.6	↗
55:	10.1	↖
56:	9.8	↘
57:	9.7	↗
58:	8.9	←
59:	9.2	↖
60:	9.0	→
Series		95.9
		572.3

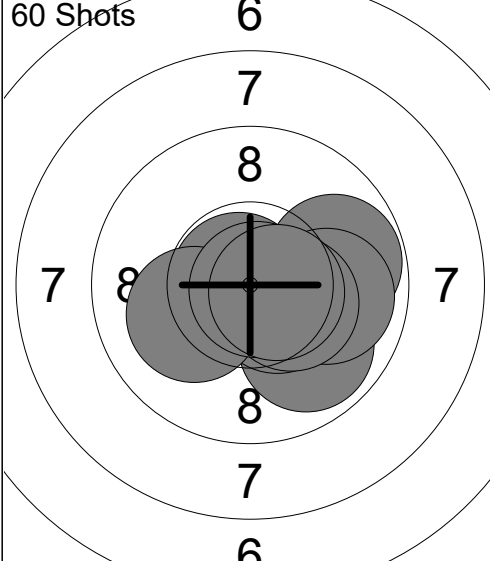
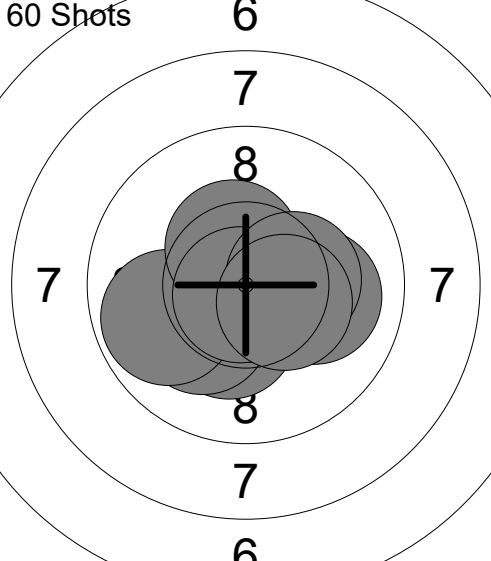
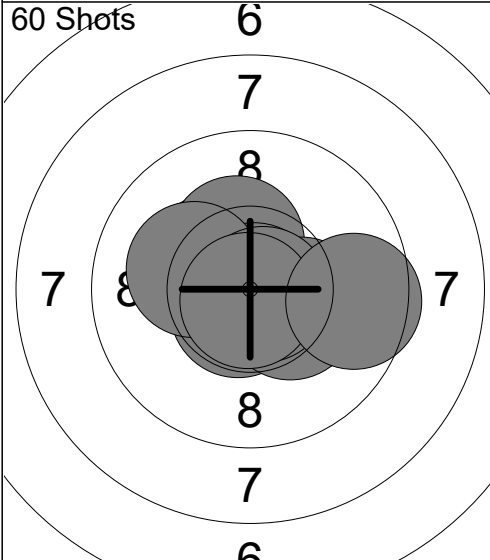
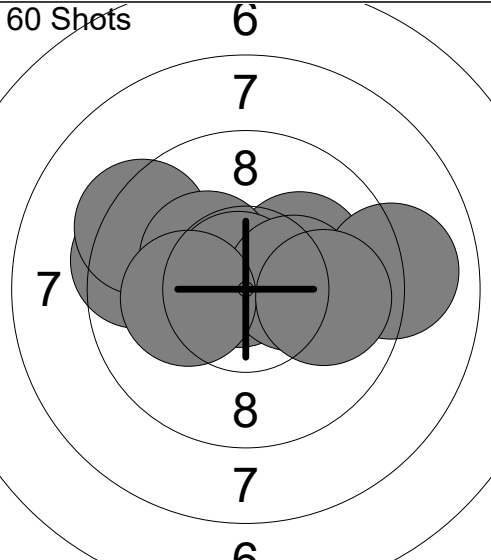
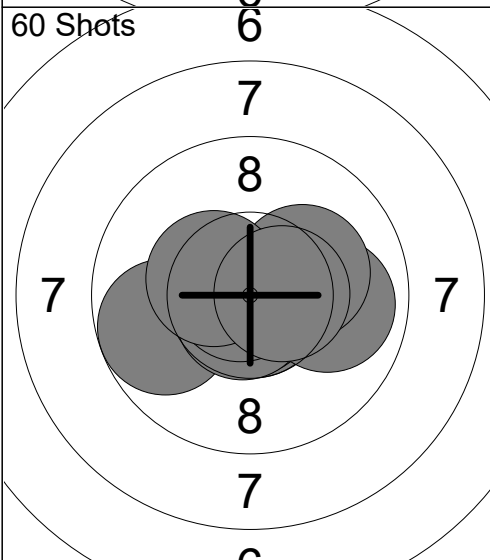
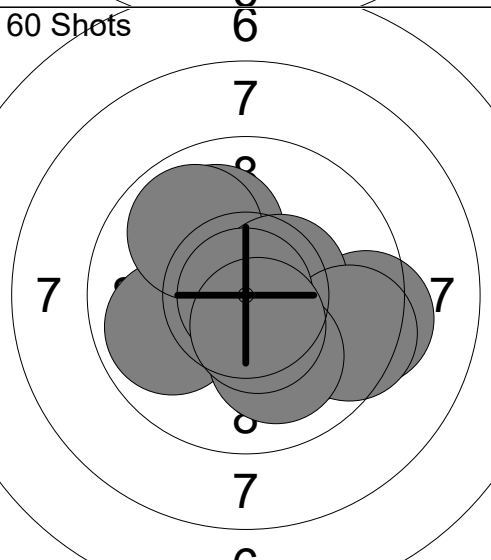
<p>60 Shots</p>  <p style="text-align: center;">6 7 8 7 8 7</p>	<p>1: 10.2x ↘ 2: 9.8 → 3: 9.9 ↘ 4: 9.9 → 5: 10.8x ↖ 6: 10.5x ↘ 7: 10.4x → 8: 10.1 ← 9: 10.8x ↘ 10: 10.6x →</p> <p>Series 103.0 103.0</p>	<p>60 Shots</p>  <p style="text-align: center;">6 7 8 7 8 7</p>	<p>11: 10.3x ↓ 12: 10.2x ↙ 13: 9.8 ← 14: 10.8x → 15: 10.4x ↑ 16: 10.0 → 17: 10.7x ↘ 18: 10.8x ↓ 19: 10.3x → 20: 10.4x →</p> <p>Series 103.7 206.7</p>
<p>60 Shots</p>  <p style="text-align: center;">6 7 8 7 8 7</p>	<p>21: 10.4x ↖ 22: 10.3x ↑ 23: 10.6x ↘ 24: 10.3x → 25: 10.9x → 26: 10.2x ↖ 27: 10.3x → 28: 10.8x → 29: 10.8x ↓ 30: 9.6 →</p> <p>Series 104.2 310.9</p>	<p>60 Shots</p>  <p style="text-align: center;">6 7 8 7 8 7</p>	<p>31: 9.5 ← 32: 9.4 ↖ 33: 10.1 → 34: 10.6x ↖ 35: 10.3x ↖ 36: 10.8x ↖ 37: 9.0 → 38: 10.3x → 39: 10.2x ← 40: 9.9 →</p> <p>Series 100.1 411.0</p>
<p>60 Shots</p>  <p style="text-align: center;">6 7 8 7 8 7 6</p>	<p>41: 9.8 ← 42: 10.8x ↓ 43: 10.9x → 44: 10.8x ↓ 45: 9.9 → 46: 10.7x ↓ 47: 10.2x → 48: 10.8x ← 49: 10.4x ↖ 50: 10.5x →</p> <p>Series 104.8 515.8</p>	<p>60 Shots</p>  <p style="text-align: center;">6 7 8 7 8 7 6</p>	<p>51: 10.0 ↑ 52: 9.9 ← 53: 9.3 → 54: 9.9 → 55: 9.9 ↑ 56: 10.5x → 57: 9.5 → 58: 10.1 ↓ 59: 10.9x ← 60: 10.5x ↓</p> <p>Series 100.5 616.3</p>

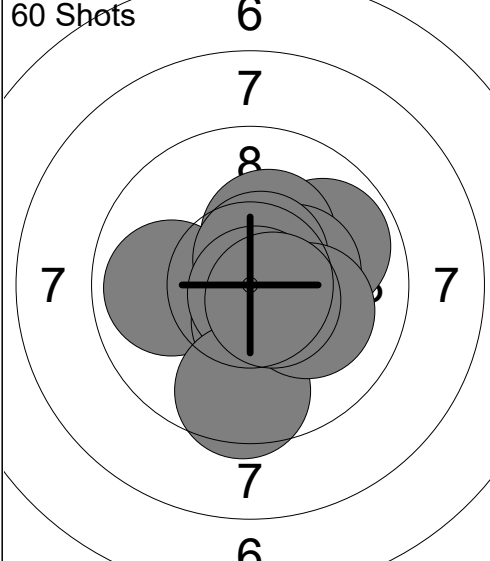
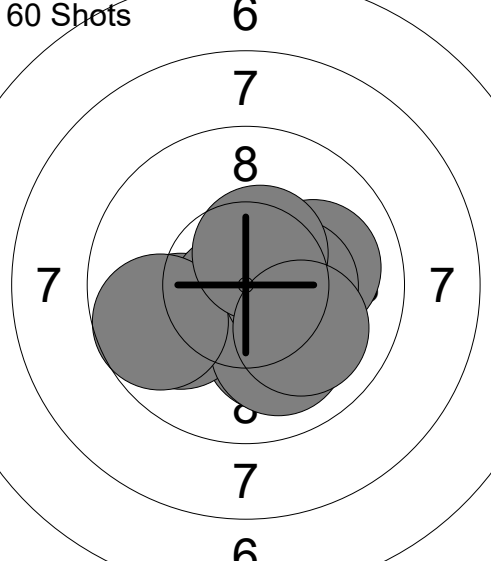
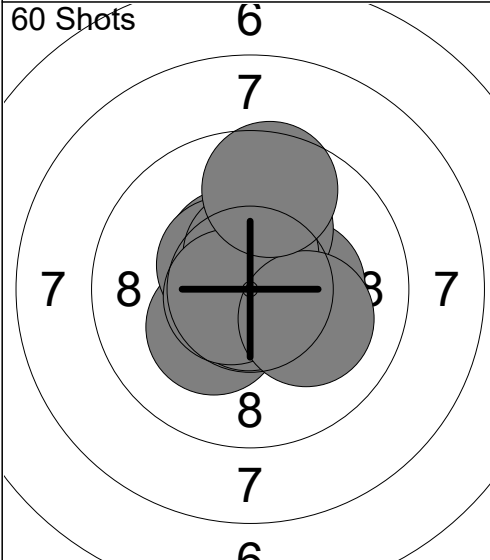
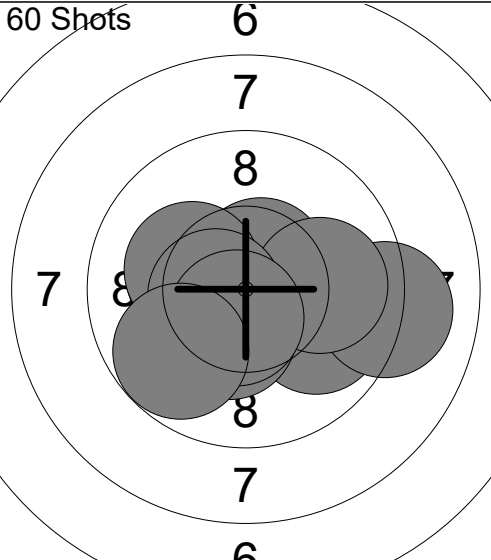
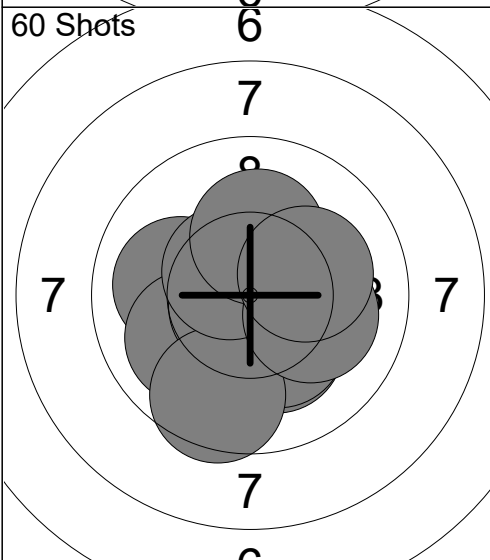
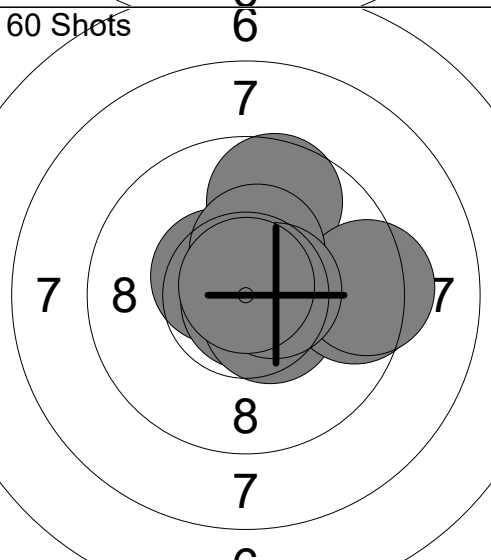
<p>60 Shots</p>  <p style="text-align: center;">6 7 8 7 7</p>	<p>1: 9.9 → 2: 10.3x ↑ 3: 9.9 ← 4: 10.4x → 5: 10.5x ↓ 6: 10.6x ↑ 7: 10.8x ↓ 8: 9.5 ↓ 9: 10.1 → 10: 10.6x ↘</p> <p>Series 102.6 102.6</p>	<p>60 Shots</p>  <p style="text-align: center;">6 7 8 7 7</p>	<p>11: 10.1 ↓ 12: 10.0 → 13: 10.5x ↙ 14: 10.0 ← 15: 10.7x ↙ 16: 10.0 ↓ 17: 10.4x → 18: 9.7 ← 19: 10.5x ↑ 20: 10.0 ↘</p> <p>Series 101.9 204.5</p>
<p>60 Shots</p>  <p style="text-align: center;">6 7 8 7 7</p>	<p>21: 10.3x ↙ 22: 10.8x ↓ 23: 10.3x → 24: 10.4x ↑ 25: 10.1 ↑ 26: 10.5x ↖ 27: 10.5x ↑ 28: 10.7x ← 29: 10.1 → 30: 9.6 ↑</p> <p>Series 103.3 307.8</p>	<p>60 Shots</p>  <p style="text-align: center;">6 7 8 7 7</p>	<p>31: 9.9 → 32: 9.1 → 33: 10.2x ← 34: 10.6x ↑ 35: 10.2x ← 36: 10.0 → 37: 10.5x ← 38: 10.3x ↓ 39: 10.5x ↓ 40: 9.8 ↙</p> <p>Series 101.1 408.9</p>
<p>60 Shots</p>  <p style="text-align: center;">6 7 8 7 6</p>	<p>41: 10.2x ↓ 42: 10.3x ↓ 43: 10.0 ← 44: 10.0 ← 45: 10.7x ↙ 46: 9.6 ↓ 47: 10.5x ↖ 48: 10.1 → 49: 10.2x ↑ 50: 10.2x →</p> <p>Series 101.8 510.7</p>	<p>60 Shots</p>  <p style="text-align: center;">6 7 8 7 6</p>	<p>51: 10.4x ↗ 52: 9.6 ↑ 53: 10.5x ↖ 54: 10.8x ↓ 55: 10.5x ↘ 56: 9.5 → 57: 9.3 → 58: 10.4x ↑ 59: 10.6x → 60: 10.8x ↑</p> <p>Series 102.4 613.1</p>

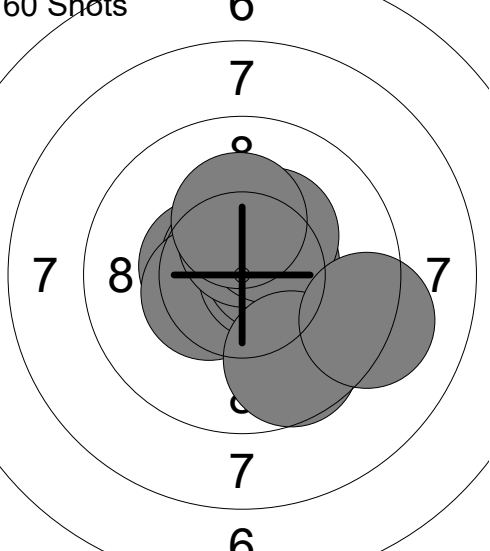
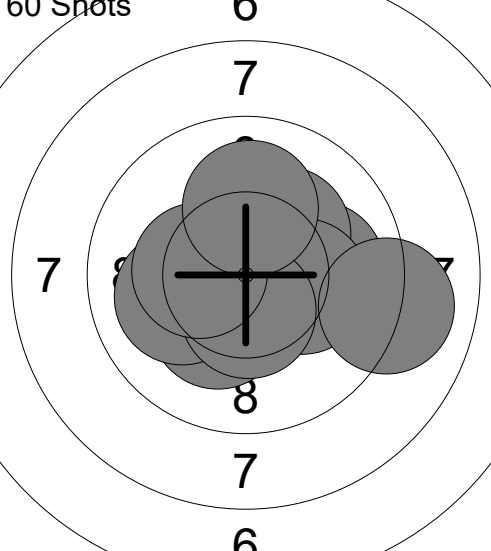
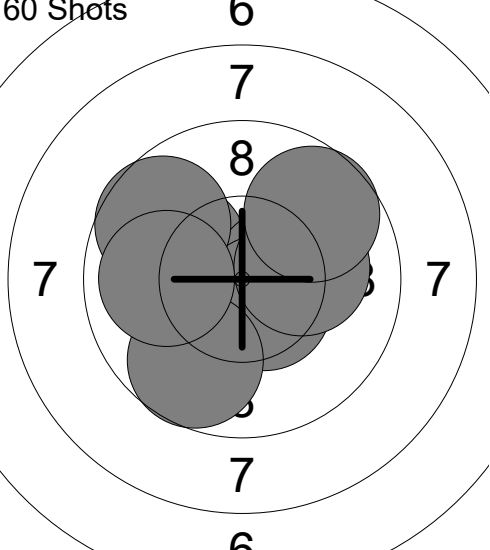
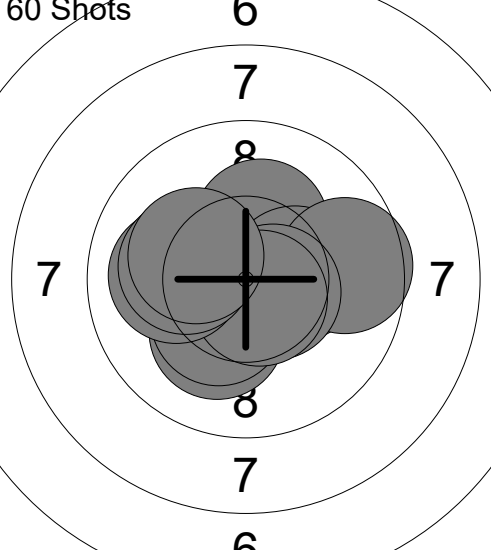
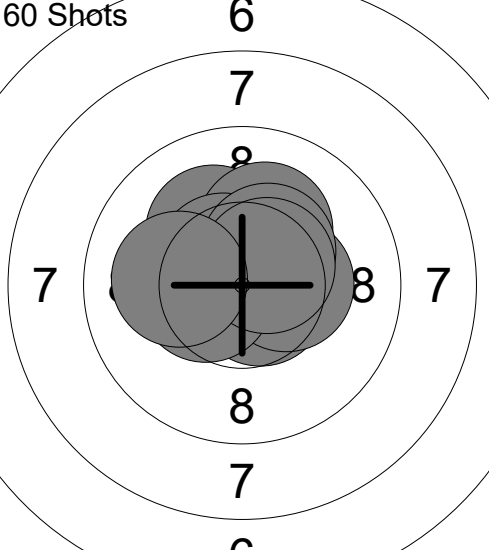
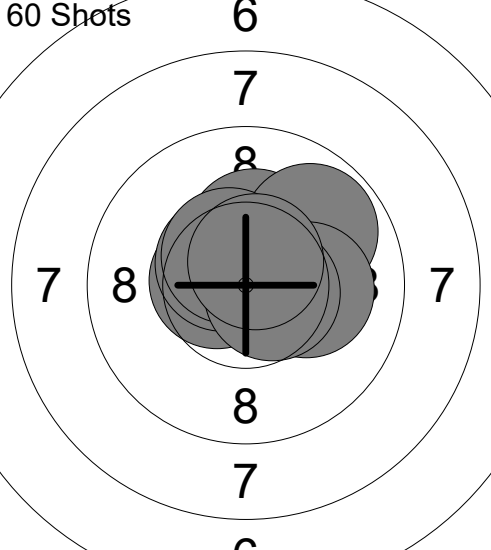
<p>60 Shots</p> 	<p>1: 10.5x ←</p> <p>2: 10.7x ↖</p> <p>3: 10.4x ←</p> <p>4: 10.6x →</p> <p>5: 10.5x →</p> <p>6: 10.5x ↑</p> <p>7: 10.3x ↗</p> <p>8: 9.7 ↓</p> <p>9: 10.2x ↑</p> <p>10: 9.2 →</p> <hr/> <p>Series 102.6</p> <hr/> <p>102.6</p>	<p>60 Shots</p> 	<p>11: 10.0 →</p> <p>12: 10.5x ↗</p> <p>13: 10.2x ↗</p> <p>14: 10.2x →</p> <p>15: 10.2x ↘</p> <p>16: 10.1 ←</p> <p>17: 9.0 →</p> <p>18: 10.5x ↓</p> <p>19: 10.3x ←</p> <p>20: 10.1 ↑</p> <hr/> <p>Series 101.1</p> <hr/> <p>203.7</p>
<p>60 Shots</p> 	<p>21: 10.5x ↘</p> <p>22: 10.3x ↖</p> <p>23: 10.0 ←</p> <p>24: 10.4x →</p> <p>25: 10.5x ↘</p> <p>26: 9.7 ↓</p> <p>27: 10.1 →</p> <p>28: 9.7 ↖</p> <p>29: 10.0 ←</p> <p>30: 9.7 ↗</p> <hr/> <p>Series 100.9</p> <hr/> <p>304.6</p>	<p>60 Shots</p> 	<p>31: 10.2x ↘</p> <p>32: 10.2x ↑</p> <p>33: 10.3x →</p> <p>34: 9.6 →</p> <p>35: 10.6x →</p> <p>36: 10.3x ↘</p> <p>37: 10.6x ↘</p> <p>38: 10.0 ←</p> <p>39: 10.1 ←</p> <p>40: 10.2x ↖</p> <hr/> <p>Series 102.1</p> <hr/> <p>406.7</p>
<p>60 Shots</p> 	<p>41: 10.2x ↗</p> <p>42: 10.2x ↑</p> <p>43: 10.6x ↘</p> <p>44: 10.6x ↖</p> <p>45: 10.4x →</p> <p>46: 10.6x ↖</p> <p>47: 10.4x ↗</p> <p>48: 10.5x ←</p> <p>49: 10.5x ↗</p> <p>50: 10.1 ←</p> <hr/> <p>Series 104.1</p> <hr/> <p>510.8</p>	<p>60 Shots</p> 	<p>51: 10.6x ←</p> <p>52: 10.8x ↗</p> <p>53: 10.5x ↖</p> <p>54: 10.3x ↑</p> <p>55: 9.8 ↗</p> <p>56: 10.7x →</p> <p>57: 10.1 →</p> <p>58: 10.5x ↖</p> <p>59: 10.6x →</p> <p>60: 10.6x ↑</p> <hr/> <p>Series 104.5</p> <hr/> <p>615.3</p>

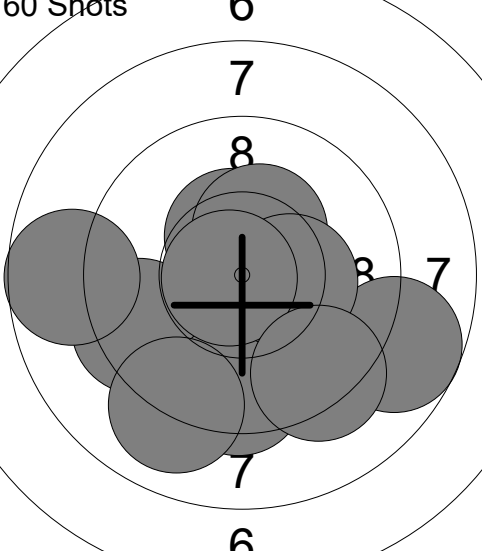
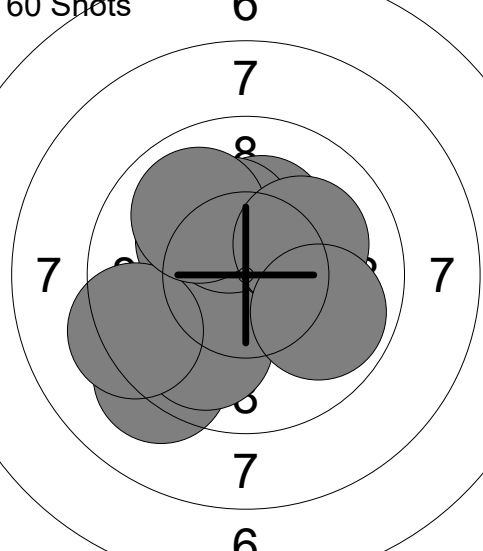
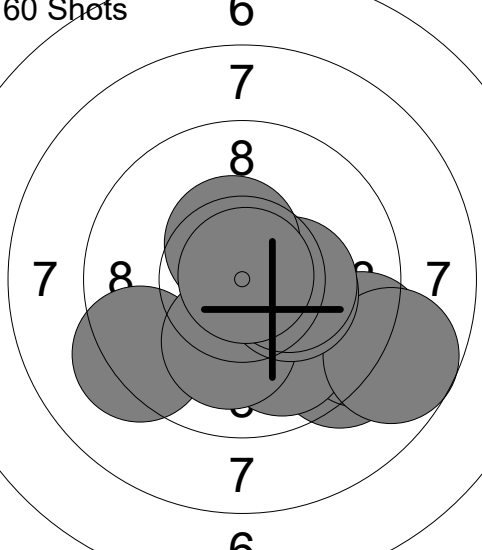
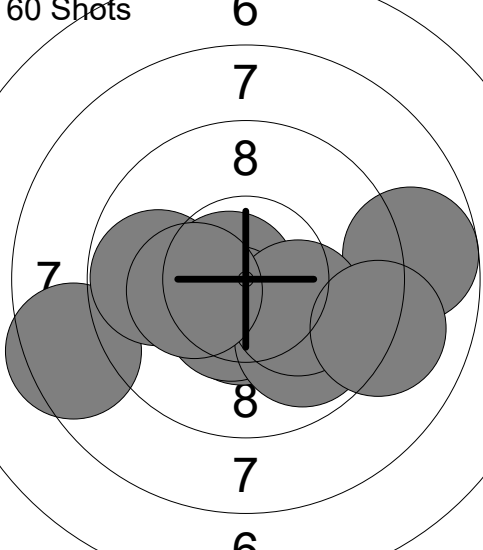
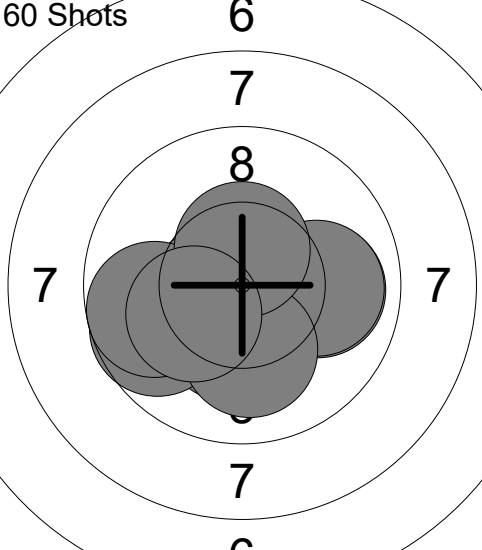
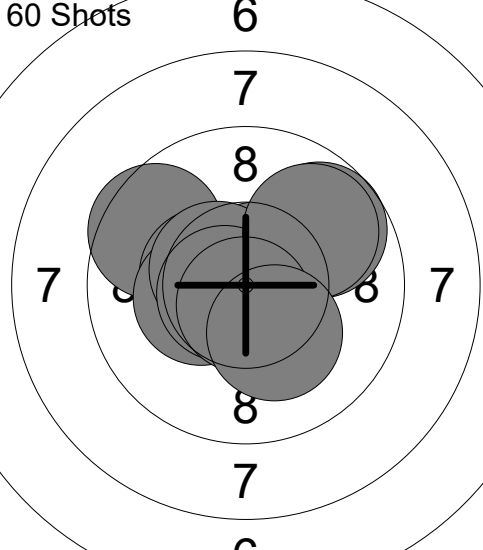
<p>60 Shots</p>  <p style="text-align: center;">6 7 8 8 7 7 7 7 7 7</p>	<p>1: 9.4 ←</p> <p>2: 9.5 ↓</p> <p>3: 8.7 →</p> <p>4: 8.7 ←</p> <p>5: 10.4x ↑</p> <p>6: 10.3x ↑</p> <p>7: 10.3x →</p> <p>8: 9.0 ↓</p> <p>9: 10.8x ←</p> <p>10: 9.3 ↓</p> <hr/> <p>Series 96.4</p> <hr/> <p style="text-align: center;">96.4</p>	<p>60 Shots</p>  <p style="text-align: center;">6 7 8 8 7 7 7 7 7 7</p>	<p>11: 10.2x ↑</p> <p>12: 10.2x ↖</p> <p>13: 9.2 ↓</p> <p>14: 10.7x ↑</p> <p>15: 9.9 ↓</p> <p>16: 9.3 ←</p> <p>17: 10.3x ↑</p> <p>18: 9.9 ↗</p> <p>19: 10.1 ↗</p> <p>20: 9.9 →</p> <hr/> <p>Series 99.7</p> <hr/> <p style="text-align: center;">196.1</p>
<p>60 Shots</p>  <p style="text-align: center;">6 7 8 8 7 7 7 7 7 7</p>	<p>21: 9.3 ←</p> <p>22: 9.3 ↓</p> <p>23: 9.2 →</p> <p>24: 9.9 ↓</p> <p>25: 8.7 →</p> <p>26: 10.1 ↓</p> <p>27: 10.3x →</p> <p>28: 10.3x →</p> <p>29: 10.5x ↑</p> <p>30: 10.9x ↗</p> <hr/> <p>Series 98.5</p> <hr/> <p style="text-align: center;">294.6</p>	<p>60 Shots</p>  <p style="text-align: center;">6 7 8 8 7 7 7 7 7 7</p>	<p>31: 10.5x ↓</p> <p>32: 8.5 ←</p> <p>33: 9.8 ←</p> <p>34: 8.7 →</p> <p>35: 10.7x ←</p> <p>36: 10.5x ↓</p> <p>37: 9.9 ↓</p> <p>38: 10.2x →</p> <p>39: 10.3x ←</p> <p>40: 9.1 →</p> <hr/> <p>Series 98.2</p> <hr/> <p style="text-align: center;">392.8</p>
<p>60 Shots</p>  <p style="text-align: center;">6 7 8 8 7 7 7 7 7 7</p>	<p>41: 10.3x ↓</p> <p>42: 10.6x ←</p> <p>43: 9.7 ←</p> <p>44: 9.8 ←</p> <p>45: 9.9 →</p> <p>46: 10.8x ↑</p> <p>47: 10.0 →</p> <p>48: 10.1 ↓</p> <p>49: 10.5x ↑</p> <p>50: 10.2x ←</p> <hr/> <p>Series 101.9</p> <hr/> <p style="text-align: center;">494.7</p>	<p>60 Shots</p>  <p style="text-align: center;">6 7 8 8 7 7 7 7 7 7</p>	<p>51: 9.7 ↗</p> <p>52: 10.7x ↑</p> <p>53: 9.6 ↖</p> <p>54: 10.4x ←</p> <p>55: 10.3x ←</p> <p>56: 10.5x ↖</p> <p>57: 10.6x ←</p> <p>58: 9.8 ↗</p> <p>59: 10.7x ↓</p> <p>60: 10.2x ↓</p> <hr/> <p>Series 102.5</p> <hr/> <p style="text-align: center;">597.2</p>

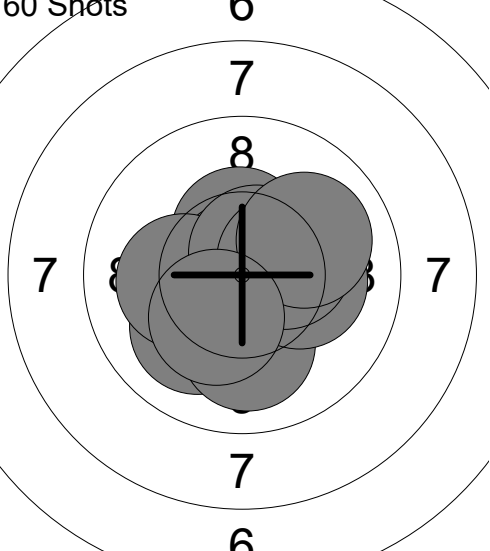
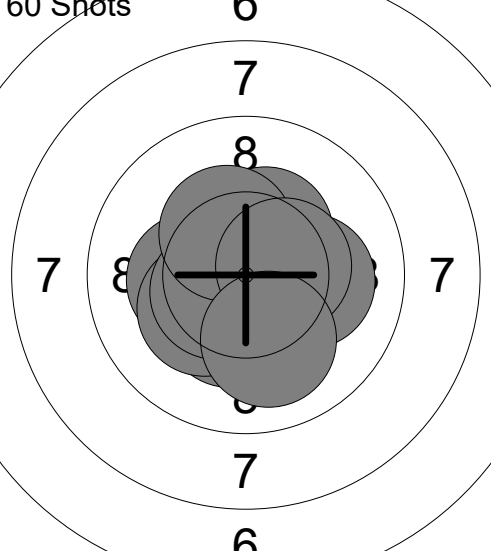
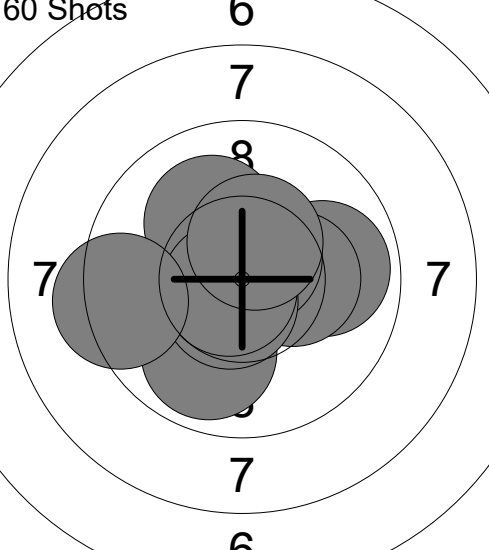
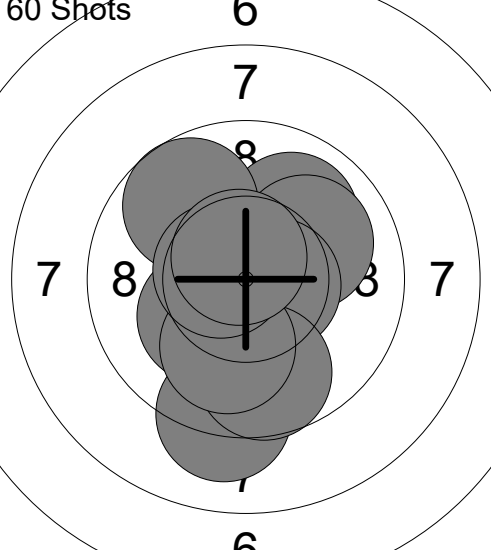
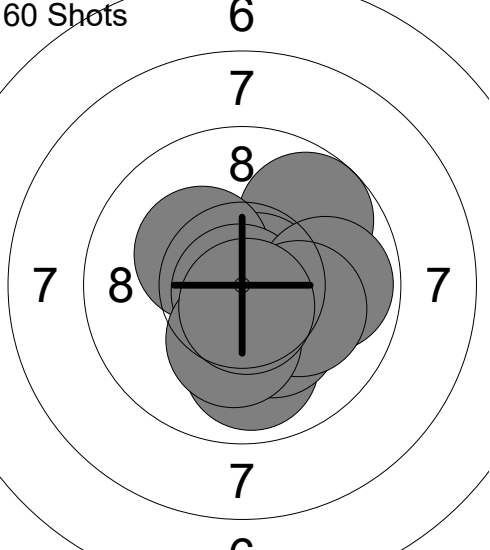
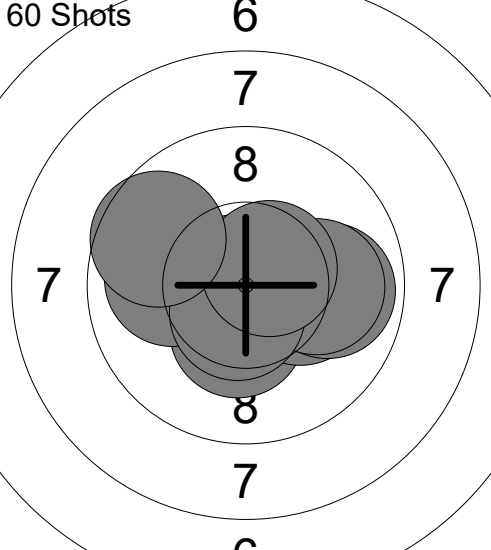
<p>60 Shots</p> 	<p>1: 10.4x ↑ 2: 10.0 ↙ 3: 10.0 ↓ 4: 10.8x ↑ 5: 10.2x → 6: 10.2x ← 7: 10.6x ↗ 8: 10.4x → 9: 10.0 ↗ 10: 10.3x ↓</p> <p>Series 102.9</p> <p style="text-align: center;">102.9</p>	<p>60 Shots</p> 	<p>11: 10.7x ↓ 12: 10.3x ← 13: 10.3x ↓ 14: 10.4x ↗ 15: 10.3x ↙ 16: 10.5x ← 17: 10.1 → 18: 10.3x ↗ 19: 10.4x → 20: 10.0 ↓</p> <p>Series 103.3</p> <p style="text-align: center;">206.2</p>
<p>60 Shots</p> 	<p>21: 9.9 → 22: 9.9 ↓ 23: 10.5x ← 24: 10.1 ↗ 25: 10.3x → 26: 10.6x ↗ 27: 10.6x ↓ 28: 10.7x ↙ 29: 10.4x ↑ 30: 9.3 ←</p> <p>Series 102.3</p> <p style="text-align: center;">308.5</p>	<p>60 Shots</p> 	<p>31: 10.0 ↗ 32: 9.1 ↓ 33: 10.0 ↗ 34: 10.6x → 35: 9.7 ↗ 36: 10.2x ↙ 37: 9.7 ↓ 38: 10.0 ↓ 39: 10.6x ← 40: 10.6x ↗</p> <p>Series 100.5</p> <p style="text-align: center;">409.0</p>
<p>60 Shots</p> 	<p>41: 9.7 ↗ 42: 9.9 ↓ 43: 10.8x → 44: 10.3x ↙ 45: 10.2x ↓ 46: 10.9x ↓ 47: 9.8 → 48: 10.1 → 49: 10.2x ↓ 50: 10.7x ↓</p> <p>Series 102.6</p> <p style="text-align: center;">511.6</p>	<p>60 Shots</p> 	<p>51: 10.8x ← 52: 10.4x ↓ 53: 10.6x → 54: 10.2x → 55: 9.9 → 56: 10.0 ← 57: 10.0 → 58: 10.6x ↓ 59: 10.6x ↗ 60: 9.6 ↙</p> <p>Series 102.7</p> <p style="text-align: center;">614.3</p>

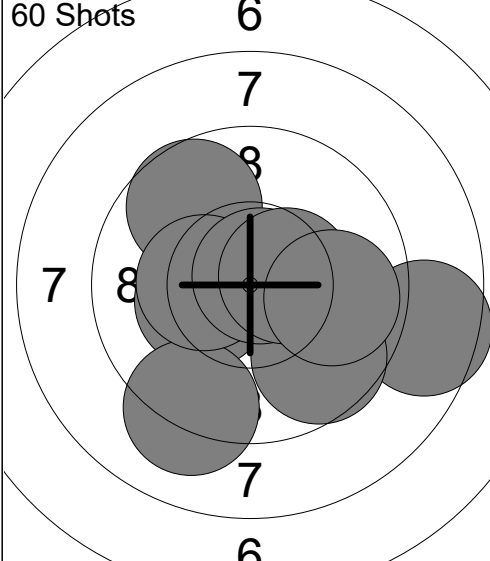
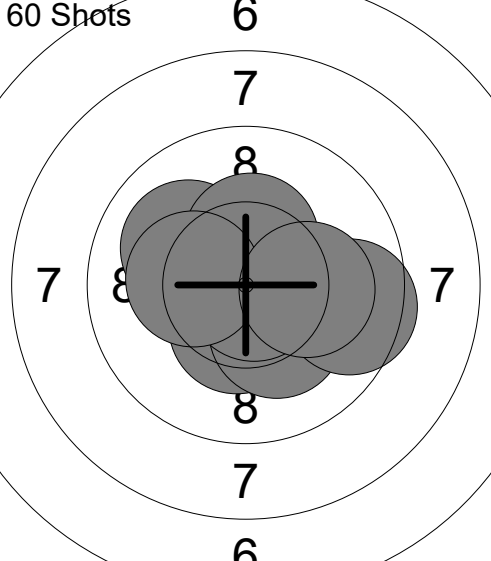
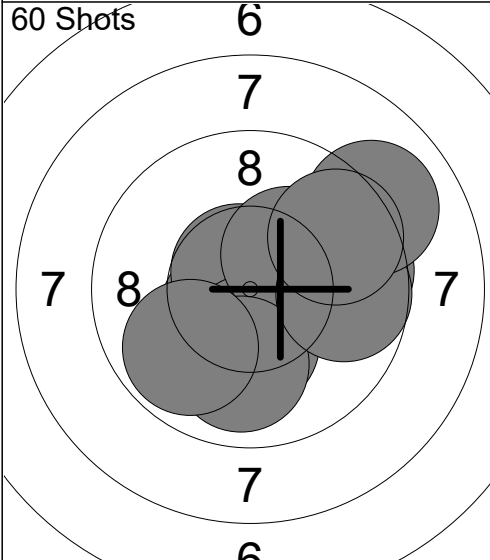
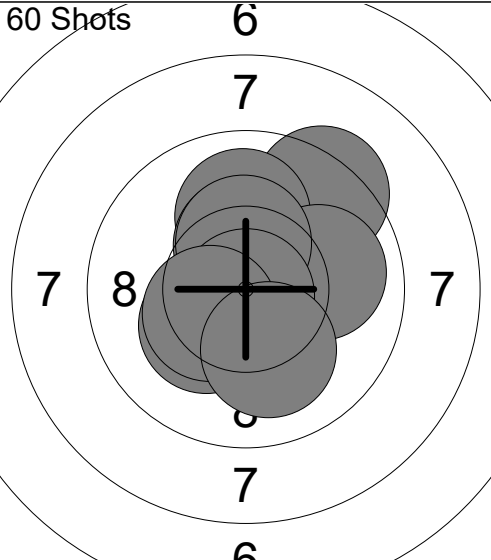
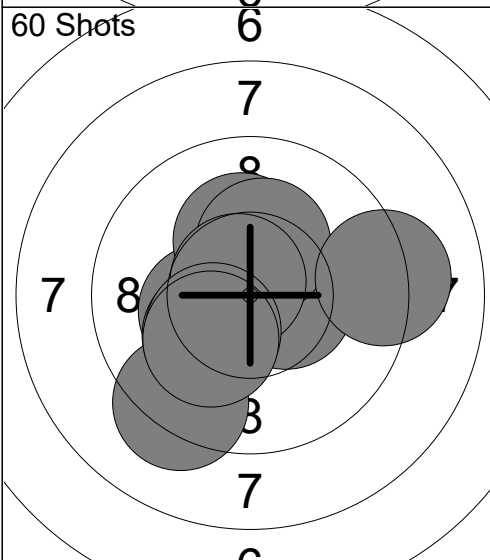
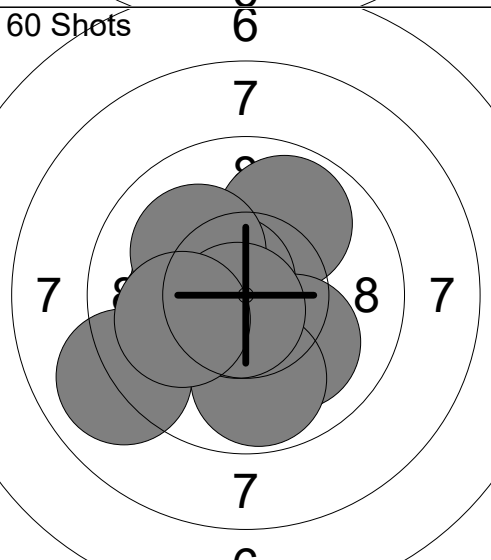
60 Shots 	1: 10.3x ← 2: 10.4x ← 3: 9.1 ↓ 4: 8.6 → 5: 9.6 ↘ 6: 9.7 ↗ 7: 10.3x ← 8: 10.8x ↗ 9: 10.5x → 10: 9.9 → Series 99.2 99.2	60 Shots 	11: 10.5x ← 12: 10.4x ↓ 13: 10.6x ↘ 14: 10.2x ↘ 15: 10.0 ↖ 16: 10.8x ↘ 17: 9.5 → 18: 10.4x ↑ 19: 10.3x ← 20: 10.1 → Series 102.8 202.0
60 Shots 	21: 10.6x ↙ 22: 10.7x ↖ 23: 9.7 → 24: 10.2x ↓ 25: 10.3x ↗ 26: 10.0 ↓ 27: 9.8 ↙ 28: 9.7 → 29: 9.0 ↗ 30: 9.6 ↗ Series 99.6 301.6	60 Shots 	31: 9.3 ↗ 32: 10.0 ↑ 33: 10.7x → 34: 10.0 → 35: 10.4x ↑ 36: 10.3x ↑ 37: 10.9x ↓ 38: 10.2x ↙ 39: 10.4x ↙ 40: 10.1 ↓ Series 102.3 403.9
60 Shots 	41: 10.5x → 42: 10.3x ← 43: 10.2x ↑ 44: 10.3x ↑ 45: 9.2 → 46: 9.3 ↙ 47: 10.7x ↖ 48: 10.2x ↙ 49: 10.3x ↙ 50: 10.2x ↙ Series 101.2 505.1	60 Shots 	51: 9.9 ↗ 52: 10.1 ← 53: 10.1 ↘ 54: 10.3x ← 55: 10.7x ↖ 56: 9.0 ↙ 57: 10.1 ↖ 58: 9.8 ↓ 59: 10.7x ↘ 60: 10.0 ← Series 100.7 605.8

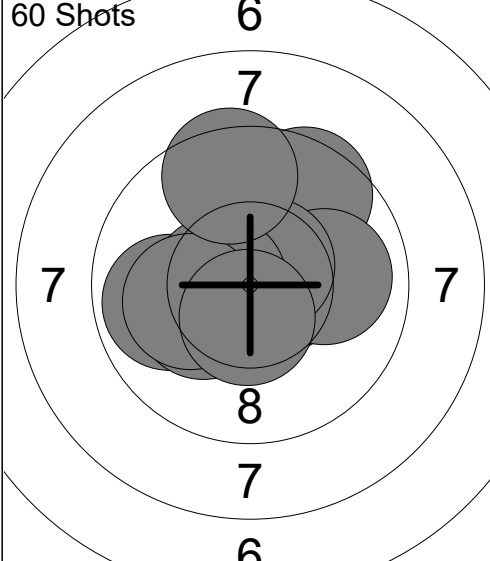
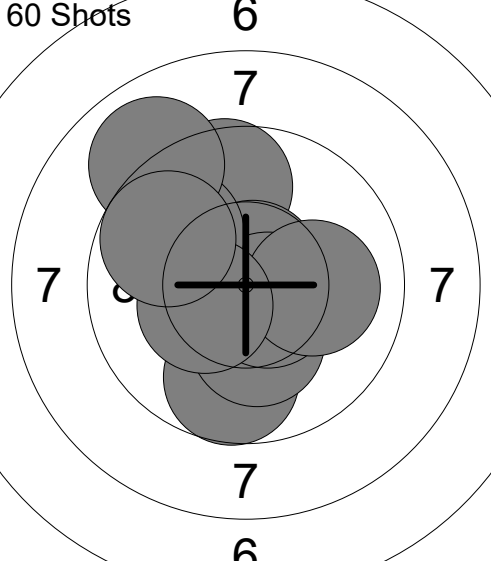
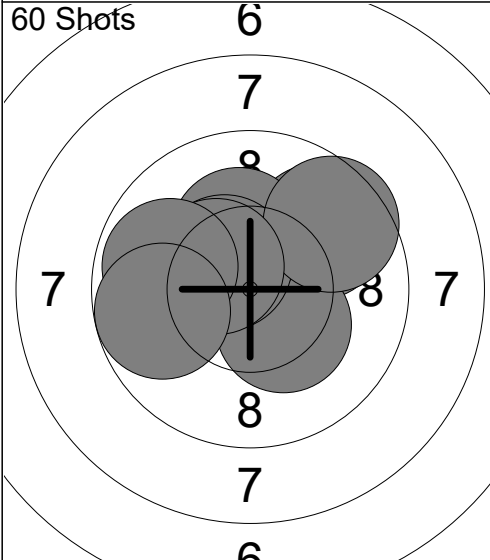
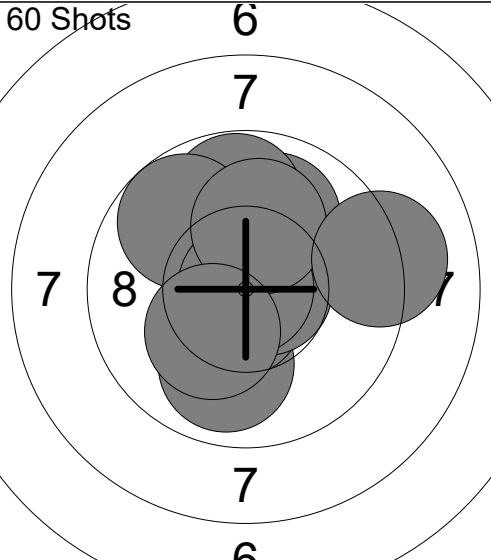
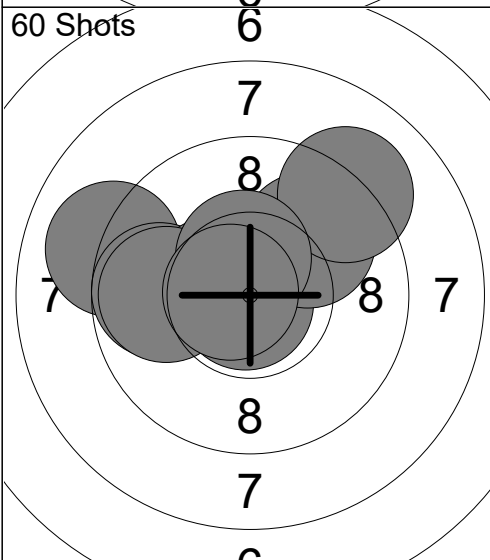
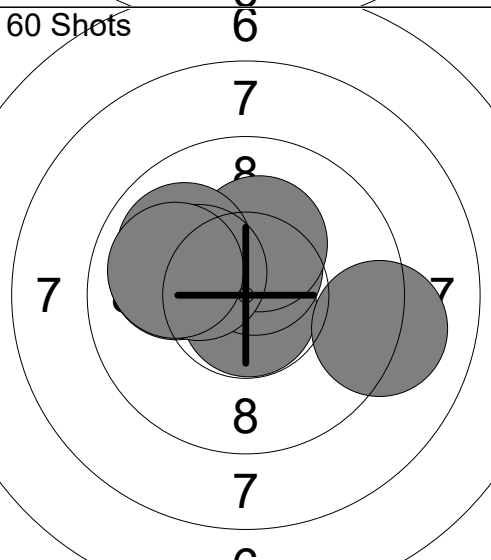
60 Shots 	1: 9.6 ↗ 2: 10.6x → 3: 9.9 ← 4: 10.2x ↙ 5: 10.0 → 6: 10.6x ↗ 7: 10.5x ← 8: 10.1 ← 9: 10.5x ↓ 10: 9.5 ↑ <hr/> Series 101.5 101.5	60 Shots 	11: 9.6 ↗ 12: 9.7 ↓ 13: 10.7x ↗ 14: 10.2x ↓ 15: 10.6x ↘ 16: 10.1 → 17: 9.8 ↖ 18: 10.3x ↙ 19: 9.0 ↗ 20: 9.7 ↖ <hr/> Series 99.7 201.2
60 Shots 	21: 10.2x ↗ 22: 9.8 ↗ 23: 10.5x ↗ 24: 10.3x ↘ 25: 10.2x ↑ 26: 10.5x ↖ 27: 9.6 ↗ 28: 10.4x ↖ 29: 9.8 ← 30: 9.8 ← <hr/> Series 101.1 302.3	60 Shots 	31: 9.9 ↓ 32: 10.7x ↓ 33: 10.7x → 34: 10.0 ↑ 35: 9.8 ↑ 36: 9.8 ↖ 37: 10.9x ↑ 38: 10.1 ↑ 39: 10.2x ↙ 40: 9.1 → <hr/> Series 101.2 403.5
60 Shots 	41: 9.0 ← 42: 10.8x ↙ 43: 9.7 ← 44: 10.6x ↖ 45: 9.9 ↗ 46: 9.1 ↗ 47: 10.5x ↙ 48: 9.8 ← 49: 10.5x ↑ 50: 10.7x ← <hr/> Series 100.6 504.1	60 Shots 	51: 10.2x ↖ 52: 10.5x ↑ 53: 10.8x ↓ 54: 10.6x ↑ 55: 9.1 → 56: 10.2x ↑ 57: 10.0 ← 58: 9.9 ↖ 59: 10.3x ↖ 60: 10.0 ← <hr/> Series 101.6 605.7

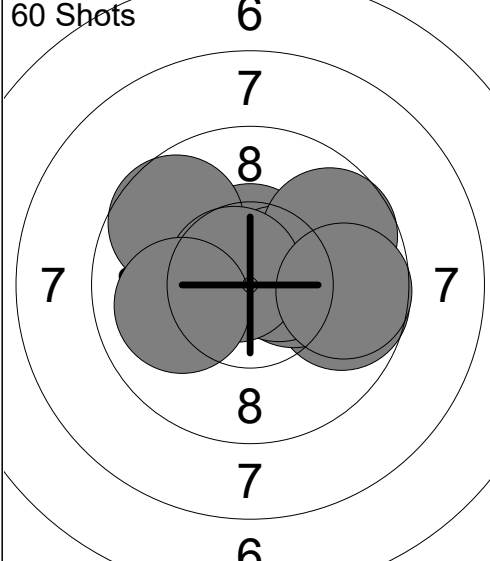
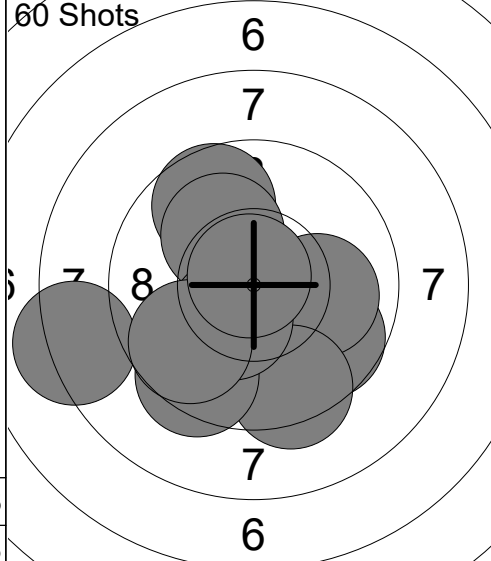
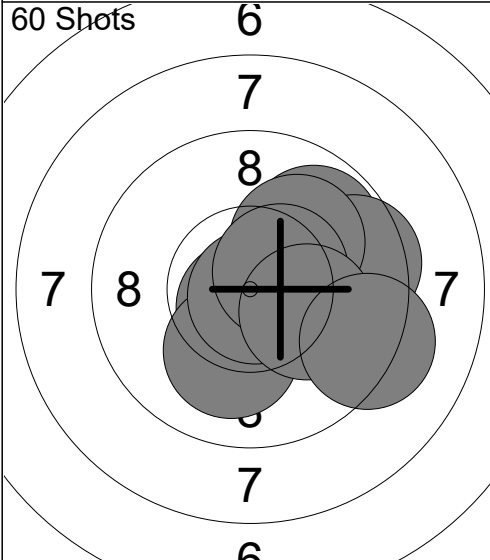
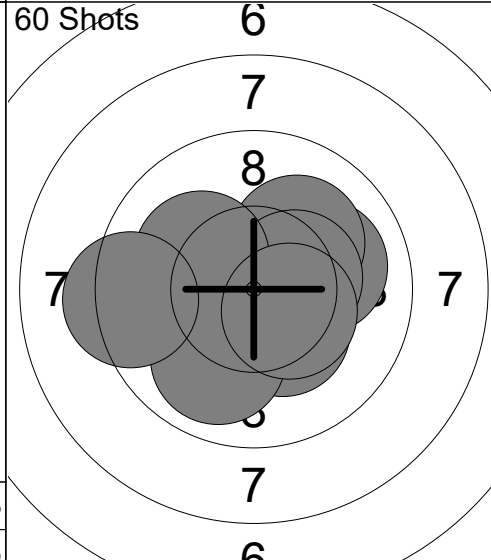
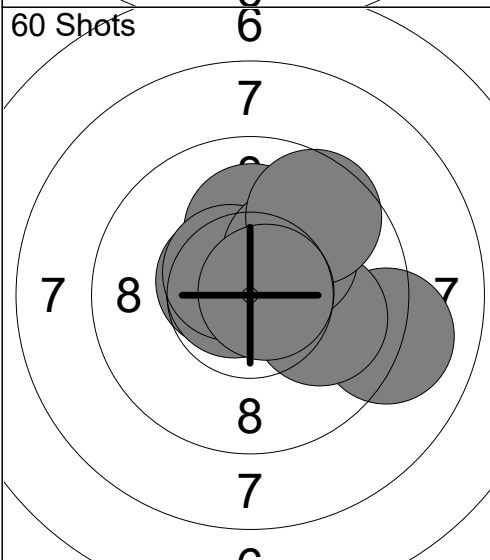
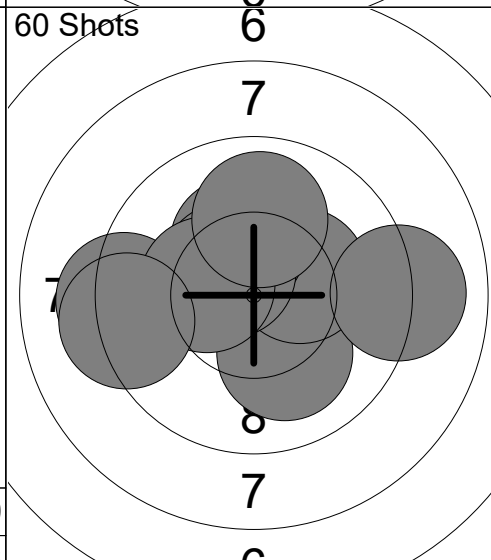
60 Shots 	1: 9.9 ↖ 2: 9.7 → 3: 10.5x ↑ 4: 9.7 ↖ 5: 10.4x → 6: 10.5x → 7: 9.7 ↗ 8: 10.7x ↖ 9: 9.7 → 10: 10.0 ← <hr/> Series 100.8 100.8	60 Shots 	11: 8.2 ← 12: 9.7 ↗ 13: 9.7 ↘ 14: 10.0 → 15: 9.4 ↘ 16: 9.4 ↘ 17: 10.1 ↗ 18: 10.4x ↘ 19: 9.7 ↘ 20: 10.8x ↗ <hr/> Series 97.4 198.2
60 Shots 	21: 10.5x ↘ 22: 10.7x ↘ 23: 9.8 ↗ 24: 10.1 ↘ 25: 10.8x ↘ 26: 9.5 → 27: 10.1 ↗ 28: 10.5x ↗ 29: 10.1 → 30: 9.2 ↘ <hr/> Series 101.3 299.5	60 Shots 	31: 10.1 ↘ 32: 10.3x ↘ 33: 10.0 → 34: 10.1 ↗ 35: 10.4x ← 36: 10.4x → 37: 10.2x ↖ 38: 9.9 ↘ 39: 10.4x ↘ 40: 9.3 ← <hr/> Series 101.1 400.6
60 Shots 	41: 9.1 → 42: 10.5x ↑ 43: 10.5x ↖ 44: 10.0 → 45: 10.7x ↖ 46: 10.1 ↑ 47: 10.6x ↖ 48: 10.2x ↗ 49: 9.6 ↗ 50: 10.7x → <hr/> Series 102.0 502.6	60 Shots 	51: 10.4x ↘ 52: 10.1 ↘ 53: 10.3x → 54: 10.2x ↑ 55: 10.5x ↖ 56: 9.2 ← 57: 10.3x ← 58: 9.9 ↑ 59: 9.0 → 60: 9.2 ← <hr/> Series 99.1 601.7

Relay 6	Lane 54	DRULEY Niko
-------------------	-------------------	--------------------

1-80	The X Count Blue	Precision	
------	------------------	-----------	--

31.01.2025	2025 AirNats by X Count	Civilian Marksmanship Program	
------------	-------------------------	-------------------------------	--

Comment	Signature		
---------	-----------	--	--

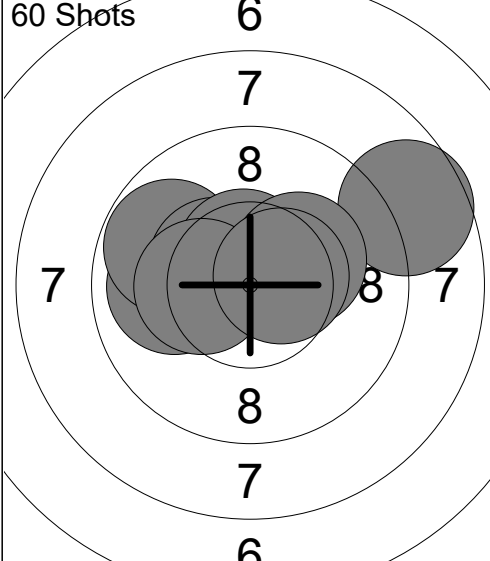
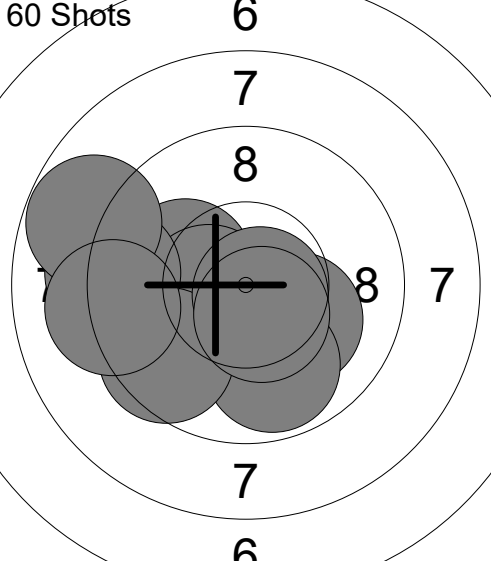
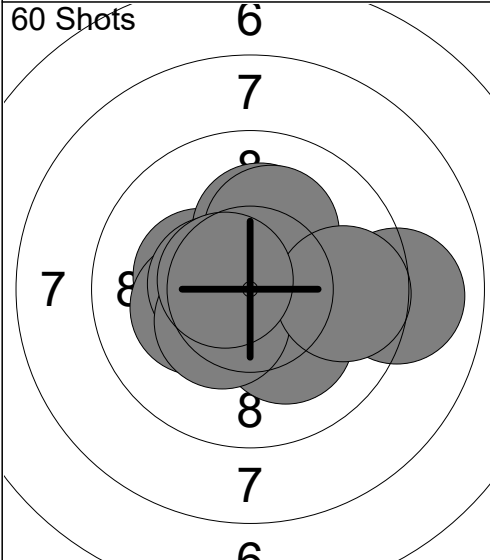
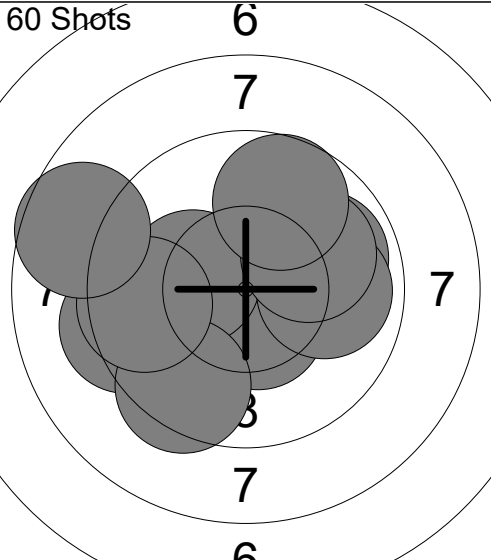
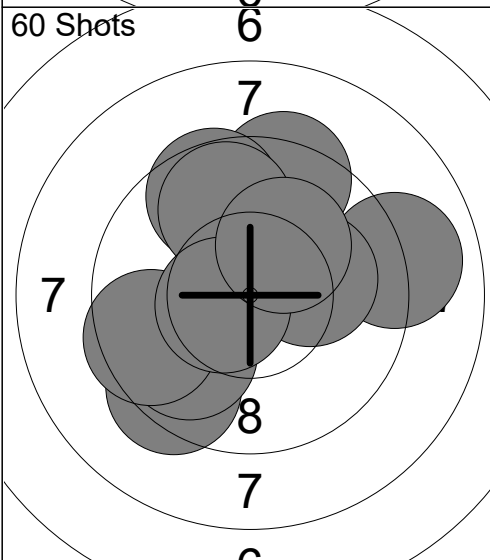
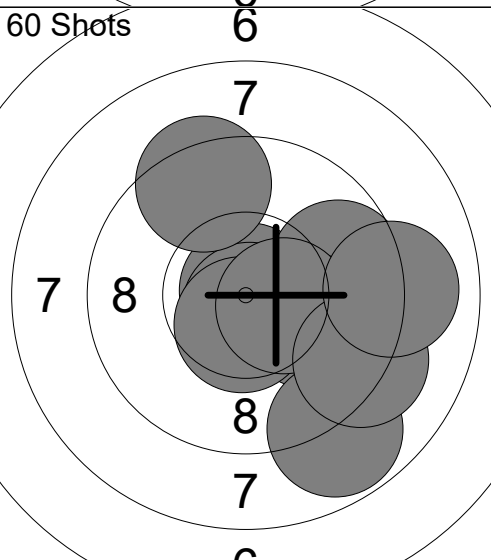
<p>60 Shots</p>  <p style="text-align: center;">6 7 8 7 8 7</p> <p style="text-align: center;">Series 100.9</p>	<p>1: 10.1 ←</p> <p>2: 10.5x ↗</p> <p>3: 9.9 ←</p> <p>4: 9.8 ↖</p> <p>5: 10.4x ↖</p> <p>6: 10.6x ↑</p> <p>7: 8.6 →</p> <p>8: 10.2x ↗</p> <p>9: 10.3x ←</p> <p>10: 10.5x →</p> <p style="text-align: center;">Series 100.9</p>	<p>60 Shots</p>  <p style="text-align: center;">6 7 8 7 7</p> <p style="text-align: center;">Series 98.4</p>	<p>11: 10.2x ↘</p> <p>12: 10.1 ←</p> <p>13: 10.4x ←</p> <p>14: 9.8 ↓</p> <p>15: 9.5 ↙</p> <p>16: 9.2 ←</p> <p>17: 10.7x ↘</p> <p>18: 8.8 ←</p> <p>19: 9.2 ←</p> <p>20: 10.5x ↓</p> <p style="text-align: center;">Series 199.3</p>
<p>60 Shots</p>  <p style="text-align: center;">6 7 8 7</p> <p style="text-align: center;">Series 101.3</p>	<p>21: 10.3x ←</p> <p>22: 10.2x ↑</p> <p>23: 10.2x ←</p> <p>24: 10.2x ↓</p> <p>25: 9.0 →</p> <p>26: 10.5x ←</p> <p>27: 10.4x ↙</p> <p>28: 10.2x ↑</p> <p>29: 9.7 →</p> <p>30: 10.6x ←</p> <p style="text-align: center;">Series 300.6</p>	<p>60 Shots</p>  <p style="text-align: center;">6 7 7</p> <p style="text-align: center;">Series 97.1</p>	<p>31: 9.9 →</p> <p>32: 10.5x ↓</p> <p>33: 10.2x ←</p> <p>34: 9.9 →</p> <p>35: 9.3 ←</p> <p>36: 9.4 ↙</p> <p>37: 9.6 ←</p> <p>38: 10.0 ↗</p> <p>39: 8.6 ←</p> <p>40: 9.7 ↑</p> <p style="text-align: center;">Series 397.7</p>
<p>60 Shots</p>  <p style="text-align: center;">6 7 8 7 6</p> <p style="text-align: center;">Series 97.5</p>	<p>41: 9.4 ↑</p> <p>42: 9.4 ↙</p> <p>43: 9.9 ↙</p> <p>44: 9.6 ↑</p> <p>45: 9.0 →</p> <p>46: 10.1 →</p> <p>47: 9.5 ←</p> <p>48: 9.8 ↑</p> <p>49: 10.6x ←</p> <p>50: 10.2x ↗</p> <p style="text-align: center;">Series 495.2</p>	<p>60 Shots</p>  <p style="text-align: center;">6 7 8 7 6</p> <p style="text-align: center;">Series 98.7</p>	<p>51: 10.9x ↑</p> <p>52: 10.7x ↓</p> <p>53: 9.7 →</p> <p>54: 10.0 →</p> <p>55: 8.8 ↓</p> <p>56: 10.6x ↓</p> <p>57: 9.4 ↑</p> <p>58: 10.4x →</p> <p>59: 9.2 ↘</p> <p>60: 9.0 →</p> <p style="text-align: center;">Series 593.9</p>

Relay 6	Lane 55	WELBORN Matthew
--------------------------	--------------------------	------------------------

1-80	The X Count Blue	Precision	
------	------------------	-----------	--

31.01.2025	2025 AirNats by X Count	Civilian Marksmanship Program
------------	-------------------------	-------------------------------

Comment	Signature
---------	-----------

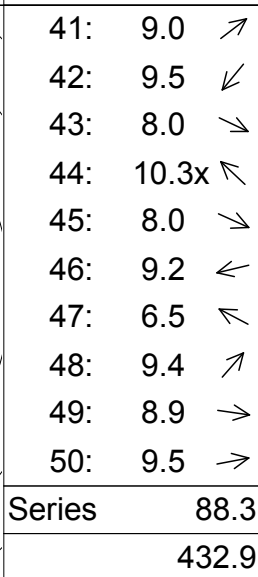
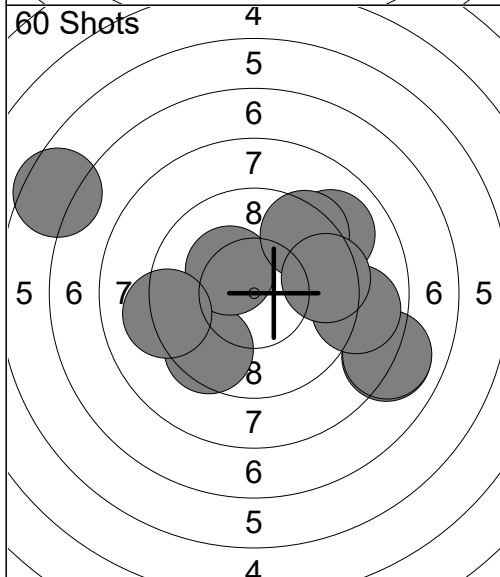
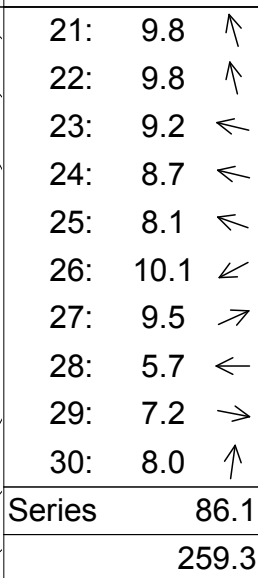
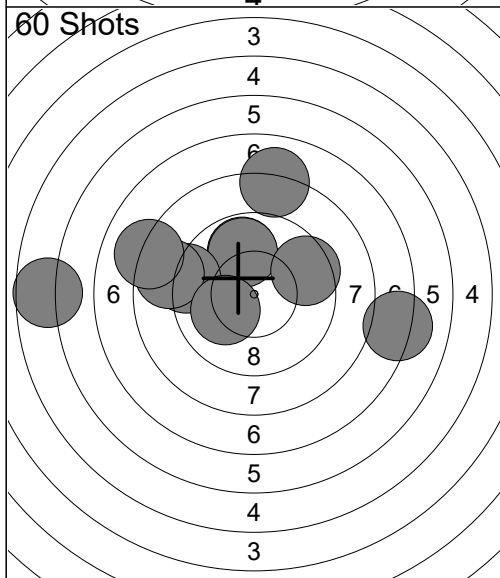
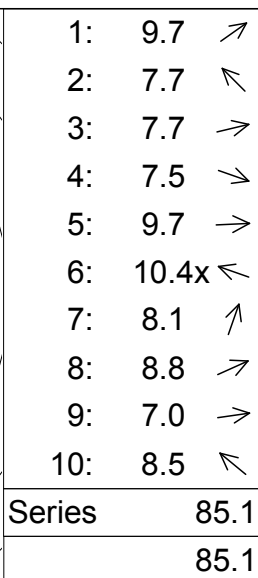
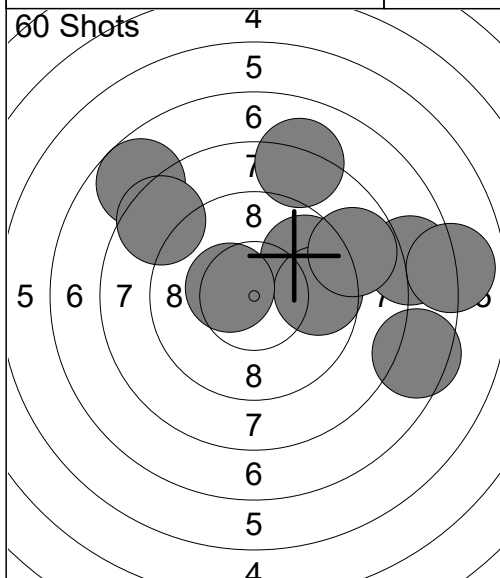

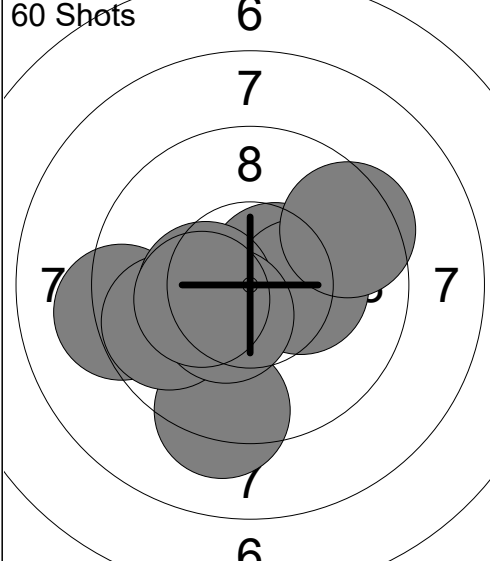
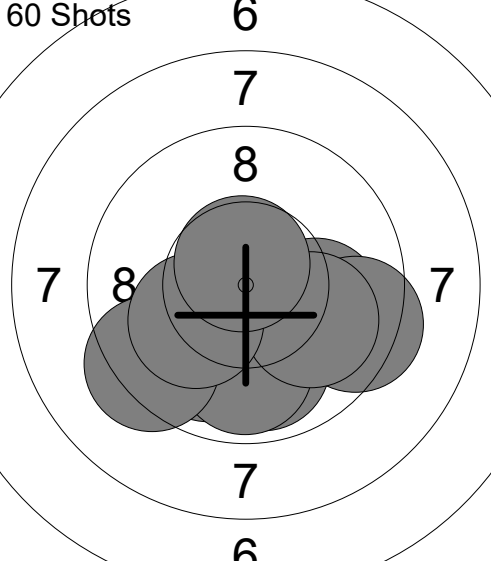
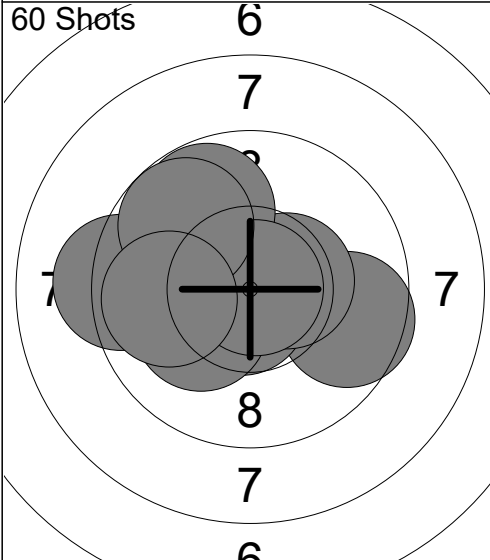
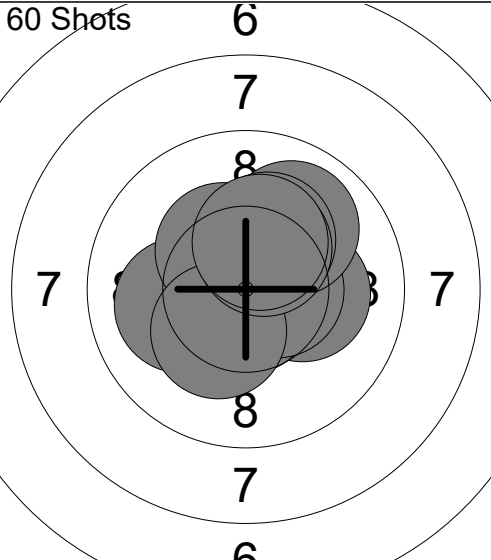
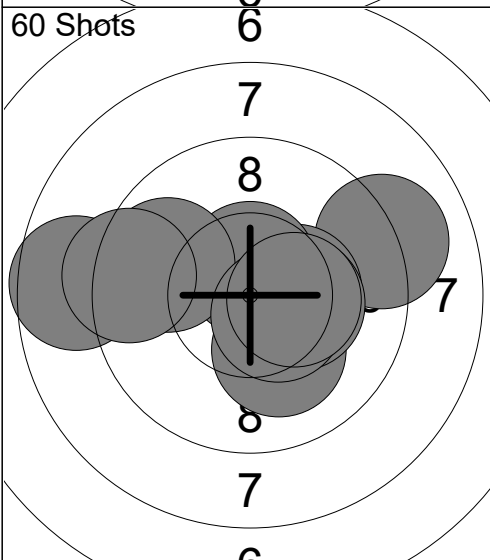
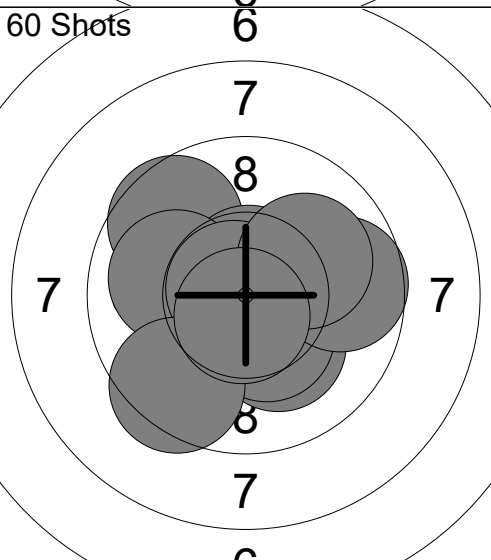
<p>60 Shots</p>  <p style="text-align: center;">6 7 8 7 7</p>	<p>1: 9.2 ←</p> <p>2: 10.6x ←</p> <p>3: 10.6x →</p> <p>4: 10.3x →</p> <p>5: 9.2 ↓</p> <p>6: 9.8 ←</p> <p>7: 10.4x ←</p> <p>8: 10.4x ↓</p> <p>9: 10.3x ←</p> <p>10: 9.5 →</p> <hr/> <p>Series 100.3</p> <p style="text-align: center;">100.3</p>	<p>60 Shots</p>  <p style="text-align: center;">6 7 8 7 7</p>	<p>11: 10.1 ↙</p> <p>12: 9.9 ↓</p> <p>13: 10.0 →</p> <p>14: 9.4 →</p> <p>15: 9.9 ↓</p> <p>16: 9.9 ↓</p> <p>17: 10.0 →</p> <p>18: 9.3 ↙</p> <p>19: 10.1 ↙</p> <p>20: 10.7x ↑</p> <hr/> <p>Series 99.3</p> <p style="text-align: center;">199.6</p>
<p>60 Shots</p>  <p style="text-align: center;">6 7 8 7 7</p>	<p>21: 9.6 →</p> <p>22: 10.7x ↓</p> <p>23: 10.2x ↖</p> <p>24: 10.5x →</p> <p>25: 9.8 ↗</p> <p>26: 10.2x ↙</p> <p>27: 10.9x →</p> <p>28: 9.2 ←</p> <p>29: 9.8 ↗</p> <p>30: 9.9 ←</p> <hr/> <p>Series 100.8</p> <p style="text-align: center;">300.4</p>	<p>60 Shots</p>  <p style="text-align: center;">6 7 8 7 7</p>	<p>31: 10.1 ←</p> <p>32: 10.2x →</p> <p>33: 10.7x ↓</p> <p>34: 10.5x →</p> <p>35: 10.0 ↗</p> <p>36: 10.2x ↗</p> <p>37: 10.4x ↖</p> <p>38: 10.3x ↙</p> <p>39: 10.4x ↗</p> <p>40: 10.3x ↗</p> <hr/> <p>Series 103.1</p> <p style="text-align: center;">403.5</p>
<p>60 Shots</p>  <p style="text-align: center;">6 7 8 7 6</p>	<p>41: 9.1 →</p> <p>42: 10.4x →</p> <p>43: 10.6x ↑</p> <p>44: 8.6 ←</p> <p>45: 10.1 ↓</p> <p>46: 9.8 ←</p> <p>47: 9.3 ←</p> <p>48: 10.3x →</p> <p>49: 10.5x ↓</p> <p>50: 10.4x →</p> <hr/> <p>Series 99.1</p> <p style="text-align: center;">502.6</p>	<p>60 Shots</p>  <p style="text-align: center;">6 7 8 7 6</p>	<p>51: 10.2x ↓</p> <p>52: 9.6 ↖</p> <p>53: 10.7x ↑</p> <p>54: 10.0 ←</p> <p>55: 10.8x ↖</p> <p>56: 10.4x ↓</p> <p>57: 9.7 →</p> <p>58: 9.5 ↙</p> <p>59: 10.0 ↗</p> <p>60: 10.7x ↓</p> <hr/> <p>Series 101.6</p> <p style="text-align: center;">604.2</p>

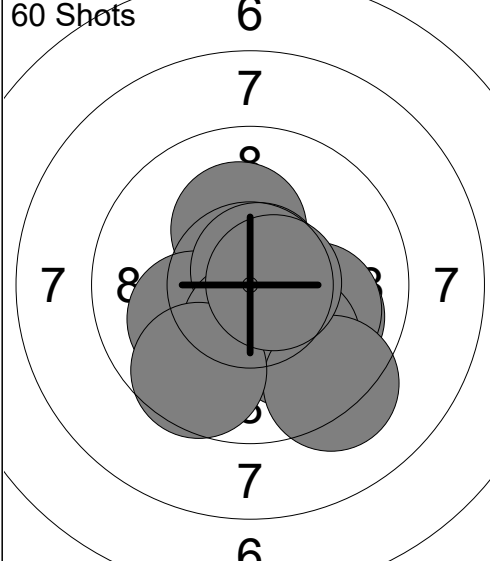
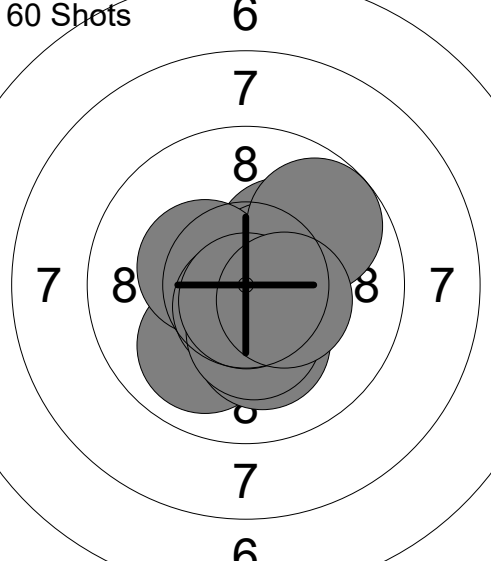
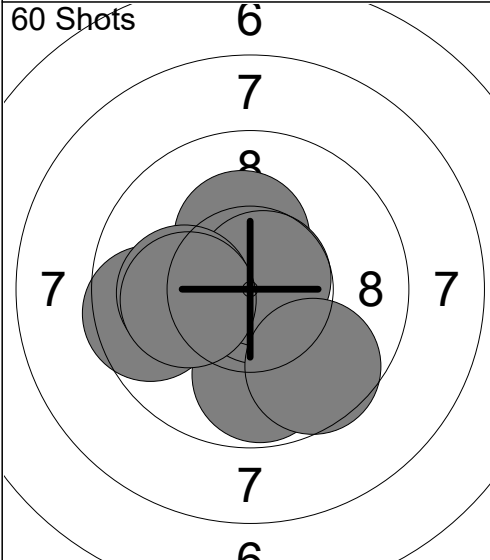
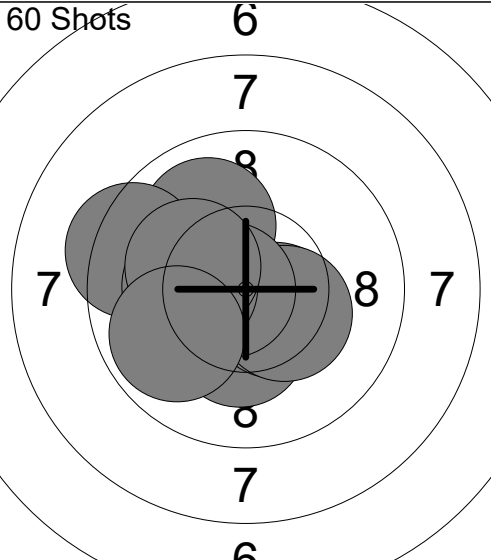
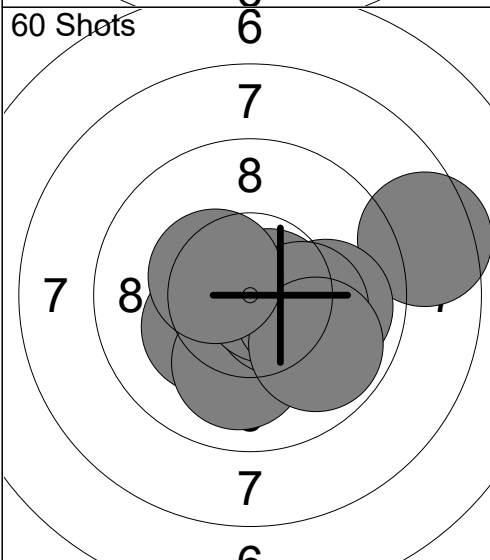
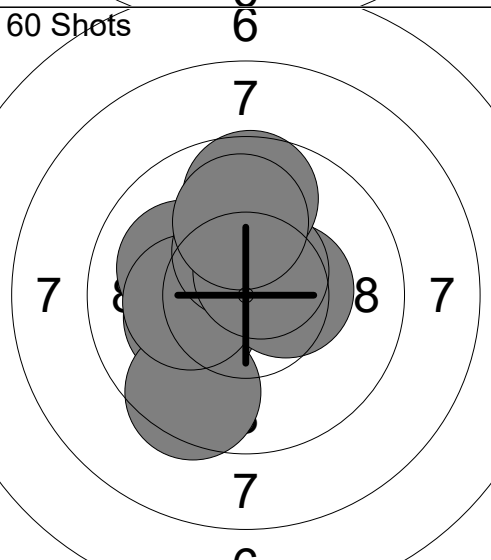
<p>60 Shots</p>  <p style="text-align: center;">6 7 7 8 7 7 8 7 7 7</p>	<p>1: 10.2x ↑</p> <p>2: 10.1 ←</p> <p>3: 10.0 →</p> <p>4: 10.0 →</p> <p>5: 10.7x ↑</p> <p>6: 10.4x ↓</p> <p>7: 10.0 ↓</p> <p>8: 9.3 ↓</p> <p>9: 9.6 ↓</p> <p>10: 10.6x →</p> <hr/> <p>Series 100.9</p>	<p>60 Shots</p>  <p style="text-align: center;">6 7 7 8 7 7 8 7 7 7</p>	<p>11: 10.2x ↗</p> <p>12: 10.0 ↙</p> <p>13: 10.6x ↗</p> <p>14: 10.4x ↖</p> <p>15: 9.7 ↗</p> <p>16: 10.6x ↓</p> <p>17: 10.2x ↓</p> <p>18: 10.3x ↓</p> <p>19: 10.7x ↓</p> <p>20: 10.4x →</p> <hr/> <p>Series 103.1</p>
100.9		204.0	
<p>60 Shots</p>  <p style="text-align: center;">6 7 7 8 7 7 8 7 7 7</p>	<p>21: 10.3x ↓</p> <p>22: 9.8 ↓</p> <p>23: 10.7x ↑</p> <p>24: 10.3x ↑</p> <p>25: 10.8x ↘</p> <p>26: 9.6 ←</p> <p>27: 10.7x ↗</p> <p>28: 10.1 ←</p> <p>29: 9.6 ↓</p> <p>30: 10.1 ←</p> <hr/> <p>Series 102.0</p>	<p>60 Shots</p>  <p style="text-align: center;">6 7 7 8 7 7 8 7 7 7</p>	<p>31: 10.6x ↓</p> <p>32: 10.3x ↓</p> <p>33: 10.0 ↗</p> <p>34: 10.5x ↘</p> <p>35: 10.3x ↘</p> <p>36: 10.7x ←</p> <p>37: 9.4 ←</p> <p>38: 10.2x ←</p> <p>39: 10.2x ↖</p> <p>40: 9.9 ↙</p> <hr/> <p>Series 102.1</p>
306.0		408.1	
<p>60 Shots</p>  <p style="text-align: center;">6 7 7 8 7 7 8 7 7 7</p>	<p>41: 10.1 ↘</p> <p>42: 8.5 →</p> <p>43: 10.3x ↙</p> <p>44: 10.0 ↓</p> <p>45: 10.5x →</p> <p>46: 10.7x →</p> <p>47: 9.9 →</p> <p>48: 10.2x →</p> <p>49: 9.9 ↓</p> <p>50: 10.4x ↖</p> <hr/> <p>Series 100.5</p>	<p>60 Shots</p>  <p style="text-align: center;">6 7 7 8 7 7 8 7 7 7</p>	<p>51: 10.2x ←</p> <p>52: 10.6x ↑</p> <p>53: 9.5 ↓</p> <p>54: 10.1 ↖</p> <p>55: 10.4x →</p> <p>56: 10.2x ←</p> <p>57: 10.4x ↑</p> <p>58: 10.6x ↗</p> <p>59: 9.7 ↑</p> <p>60: 10.0 ↑</p> <hr/> <p>Series 101.7</p>
508.6		610.3	

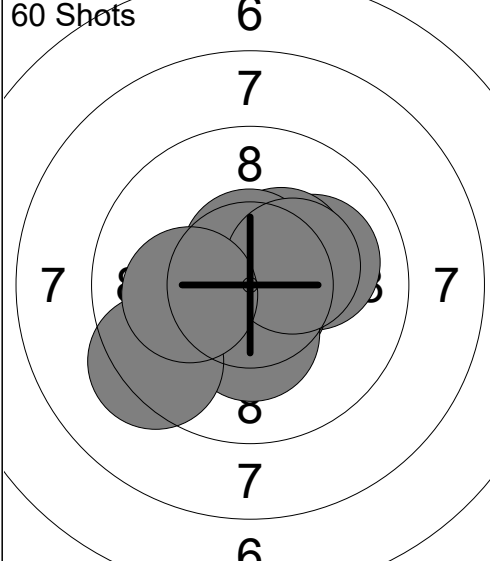
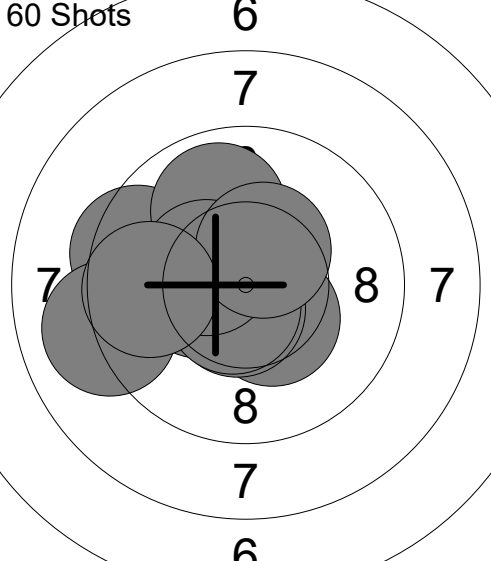
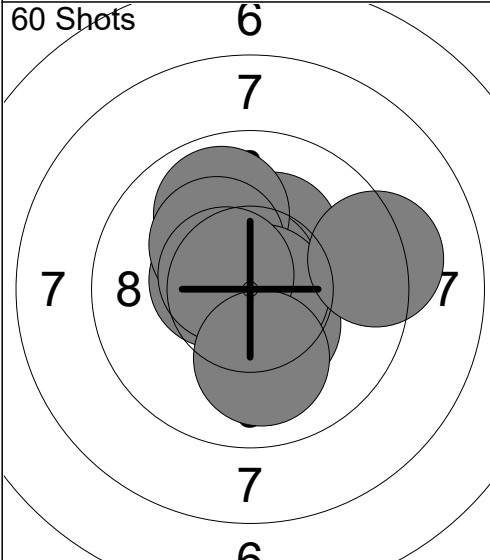
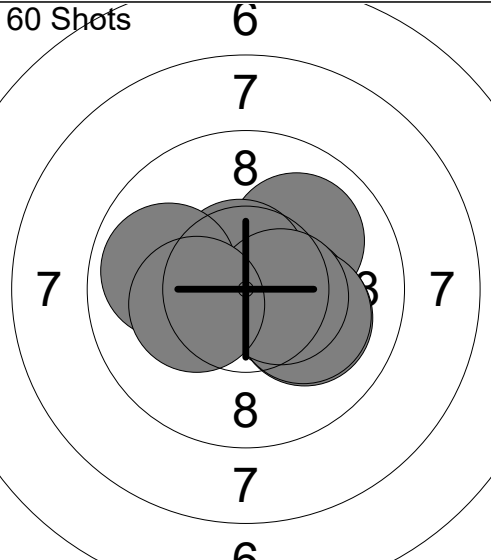
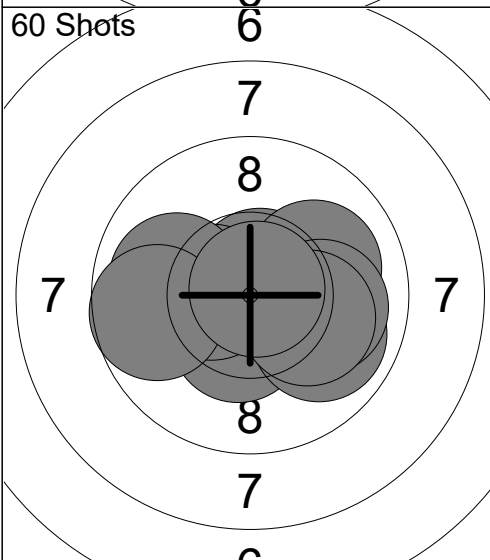
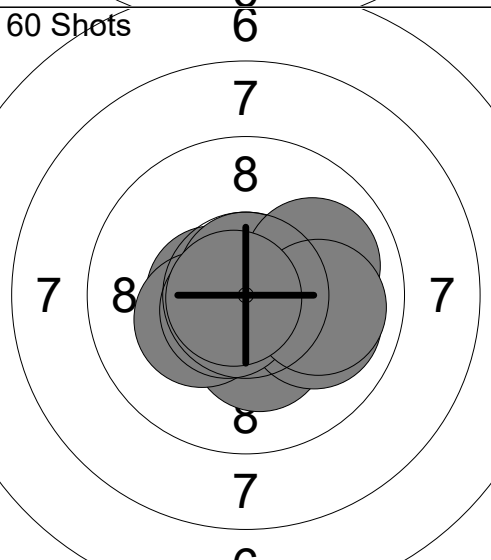
60 Shots 	1: 10.2x → 2: 10.9x ↗ 3: 10.1 → 4: 10.4x ↗ 5: 10.6x ↑ 6: 10.7x ↓ 7: 10.3x ↓ 8: 10.3x → 9: 9.3 ← 10: 10.1 ← Series 102.9 102.9	60 Shots 	11: 10.4x ↓ 12: 10.6x ↓ 13: 9.5 ← 14: 9.9 ↑ 15: 10.3x ← 16: 9.1 ← 17: 10.6x ↓ 18: 10.4x ← 19: 10.4x ↑ 20: 9.7 ← Series 100.9 203.8
60 Shots 	21: 10.2x ↑ 22: 10.7x ↑ 23: 10.5x ← 24: 9.9 ↑ 25: 10.2x ↗ 26: 10.4x ↓ 27: 10.8x → 28: 9.2 → 29: 10.6x ↖ 30: 10.0 ↓ Series 102.5 306.3	60 Shots 	31: 10.0 ↗ 32: 10.7x ← 33: 10.1 → 34: 10.9x ↖ 35: 10.4x → 36: 10.1 → 37: 10.6x ↑ 38: 10.5x → 39: 9.9 ← 40: 10.3x ← Series 103.5 409.8
60 Shots 	41: 10.7x ↑ 42: 10.4x ↓ 43: 10.4x ← 44: 10.0 ← 45: 9.9 → 46: 10.0 → 47: 9.7 ← 48: 10.0 → 49: 10.1 → 50: 10.8x ↗ Series 102.0 511.8	60 Shots 	51: 10.7x ↗ 52: 10.3x ↓ 53: 10.5x ← 54: 10.3x ← 55: 10.7x ↑ 56: 10.0 → 57: 10.0 → 58: 10.6x ↖ 59: 10.0 → 60: 10.8x ← Series 103.9 615.7

Relay 6	Lane 59	WILLIAMS Evan
-------------------	-------------------	----------------------

1-80	Lafayette Gun Club	Precision	
------	--------------------	-----------	--

31.01.2025	2025 AirNats by X Count	Civilian Marksmanship Program	
------------	-------------------------	-------------------------------	--

Comment	Signature		
---------	-----------	--	--

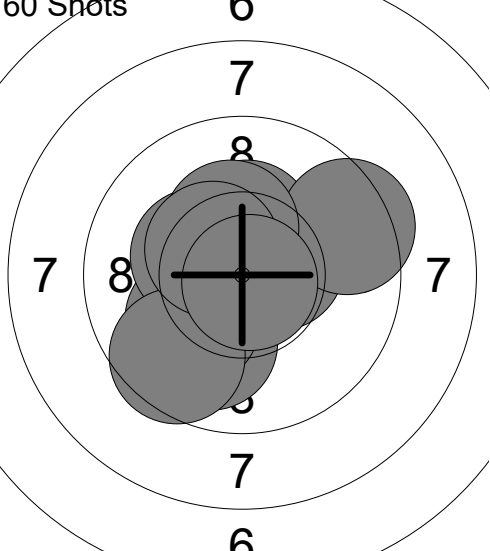
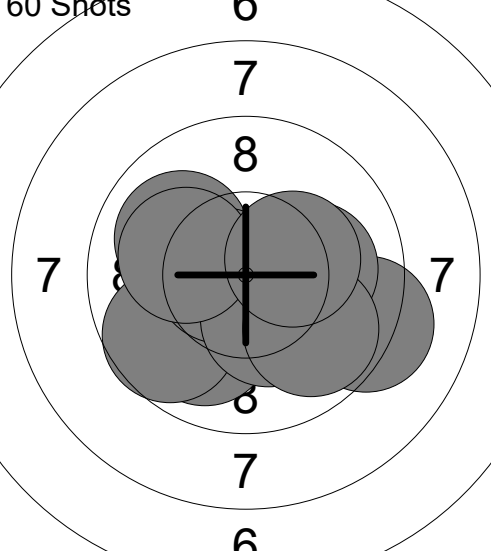
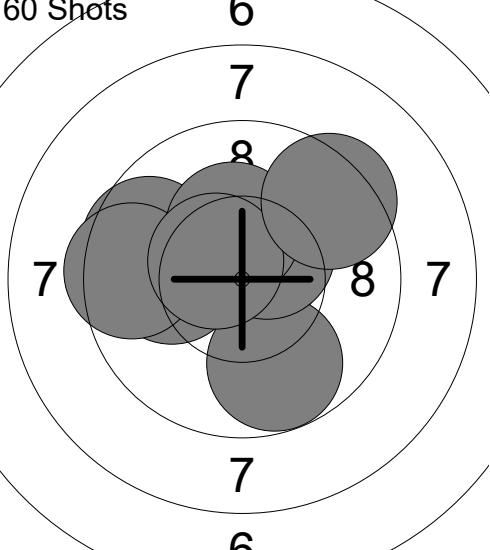
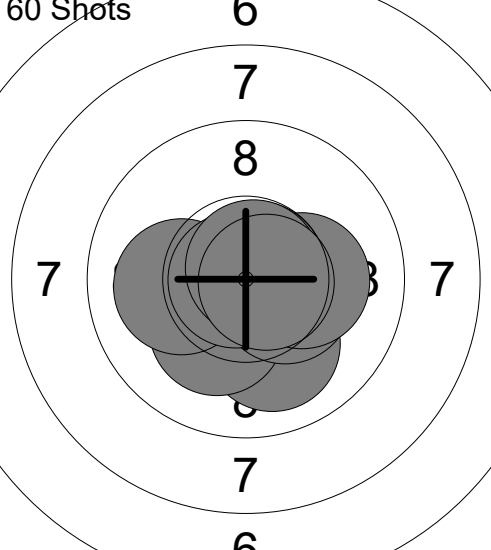
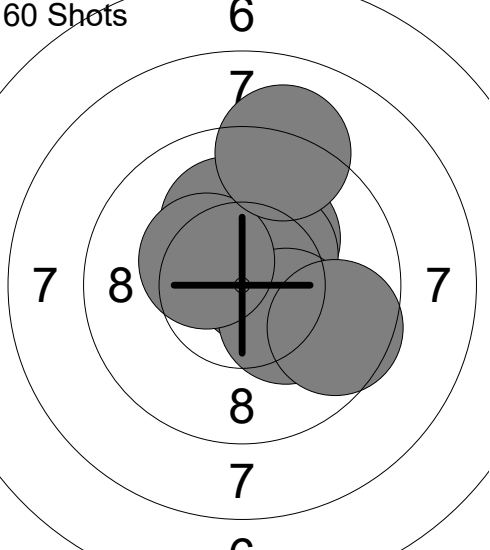
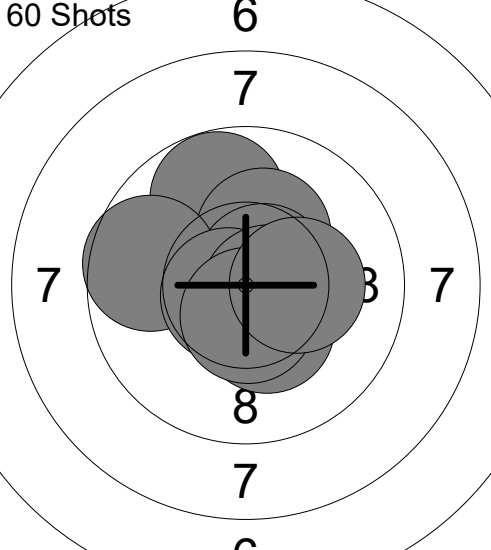
<p>60 Shots</p> 	<p>1: 10.0 ↘ 2: 10.1 ↙ 3: 10.3x ↖ 4: 10.3x ↑ 5: 9.6 ↘ 6: 10.5x → 7: 9.4 → 8: 10.3x ↑ 9: 10.4x ↖ 10: 10.8x ↘</p> <p>Series 101.7 101.7</p>	<p>60 Shots</p> 	<p>11: 10.0 ↘ 12: 9.7 ↙ 13: 10.0 ↖ 14: 10.6x ← 15: 9.2 → 16: 10.1 → 17: 10.3x ↘ 18: 9.8 ↘ 19: 10.1 ← 20: 10.3x →</p> <p>Series 100.1 201.8</p>
<p>60 Shots</p> 	<p>21: 10.0 ← 22: 9.6 ↖ 23: 10.4x ↑ 24: 10.7x ↗ 25: 9.5 ← 26: 9.8 ↘ 27: 10.5x ↗ 28: 10.3x ↑ 29: 10.5x ↖ 30: 9.4 ↗</p> <p>Series 100.7 302.5</p>	<p>60 Shots</p> 	<p>31: 10.0 ↘ 32: 10.6x ↓ 33: 10.2x ↘ 34: 10.4x → 35: 10.1 ← 36: 10.8x ← 37: 10.2x → 38: 10.8x ↗ 39: 10.8x ↗ 40: 10.7x →</p> <p>Series 104.6 407.1</p>
<p>60 Shots</p> 	<p>41: 10.2x ↗ 42: 10.6x ↑ 43: 10.6x ↖ 44: 10.1 ↑ 45: 10.7x → 46: 10.4x ↗ 47: 10.2x ↘ 48: 10.4x ↖ 49: 9.6 → 50: 9.1 ↑</p> <p>Series 101.9 509.0</p>	<p>60 Shots</p> 	<p>51: 10.3x ↘ 52: 10.0 ↑ 53: 9.8 ↑ 54: 10.3x ↑ 55: 10.7x ↗ 56: 9.7 ← 57: 10.7x ↖ 58: 10.6x → 59: 10.6x ↓ 60: 10.3x →</p> <p>Series 103.0 612.0</p>

<p>60 Shots</p>	<p>1: 10.2x ↘ 2: 10.3x ↗ 3: 9.5 ↗ 4: 10.7x ↘ 5: 10.2x ↗ 6: 9.2 → 7: 10.4x → 8: 9.4 ↗ 9: 9.5 ↗ 10: 10.4x ↖</p> <p>Series 99.8</p>	<p>60 Shots</p>	<p>11: 10.4x ↑ 12: 10.7x ↖ 13: 10.4x ↗ 14: 10.7x → 15: 10.5x ↗ 16: 9.7 ↖ 17: 10.1 ↓ 18: 10.1 ↙ 19: 10.0 ↓ 20: 10.2x ↑</p> <p>Series 102.8</p>
	99.8		202.6
<p>60 Shots</p>	<p>21: 9.9 ↖ 22: 10.5x ↑ 23: 9.5 ↑ 24: 9.8 ↖ 25: 10.5x → 26: 10.3x ↑ 27: 10.2x ↗ 28: 10.4x ↘ 29: 10.9x ↖ 30: 10.6x ↗</p> <p>Series 102.6</p>	<p>60 Shots</p>	<p>31: 10.4x ↖ 32: 9.9 ↘ 33: 10.2x ↑ 34: 10.1 ↑ 35: 10.6x ↘ 36: 10.1 ↘ 37: 10.1 → 38: 10.1 ↖ 39: 9.6 ← 40: 10.3x ←</p> <p>Series 101.4</p>
	305.2		406.6
<p>60 Shots</p>	<p>41: 10.7x ↑ 42: 10.5x ↗ 43: 10.3x ↗ 44: 10.3x ↘ 45: 10.4x ↑ 46: 10.5x → 47: 10.1 ↓ 48: 10.7x → 49: 10.2x ↑ 50: 10.8x ↘</p> <p>Series 104.5</p>	<p>60 Shots</p>	<p>51: 10.6x ↘ 52: 10.1 ↖ 53: 10.8x ↗ 54: 10.2x → 55: 10.3x ↖ 56: 10.8x ↘ 57: 10.3x ← 58: 10.5x ↘ 59: 10.3x ↘ 60: 10.8x ↑</p> <p>Series 104.7</p>
	511.1		615.8

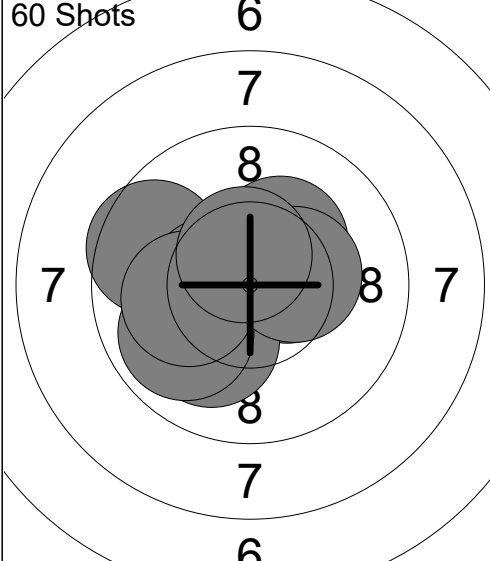
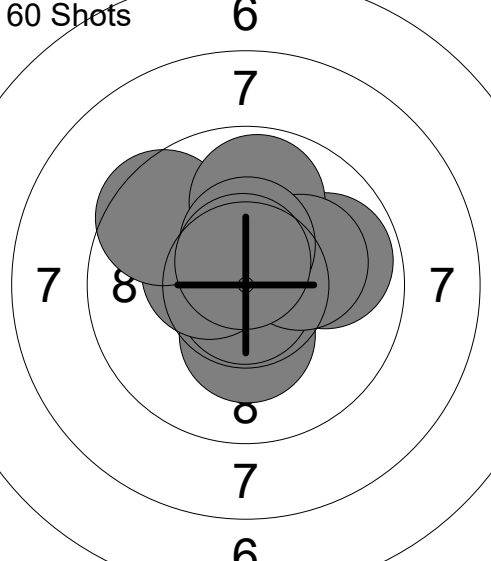
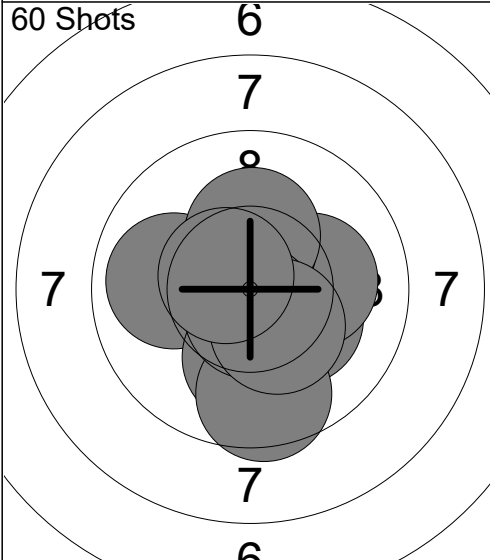
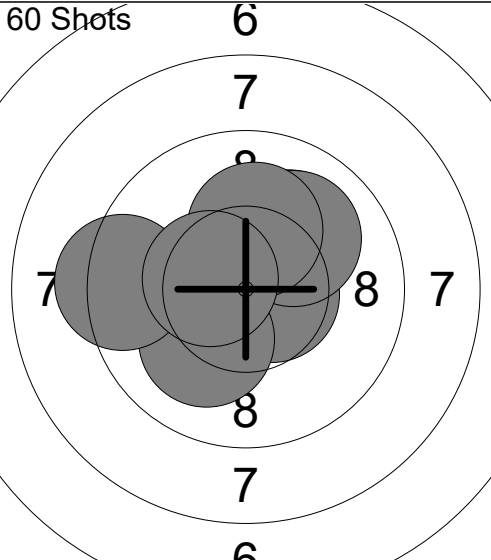
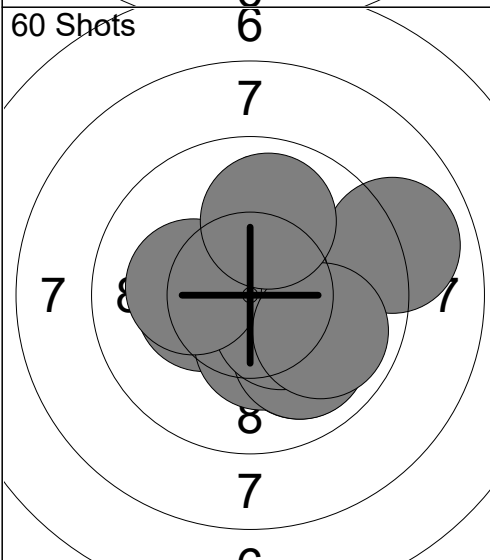
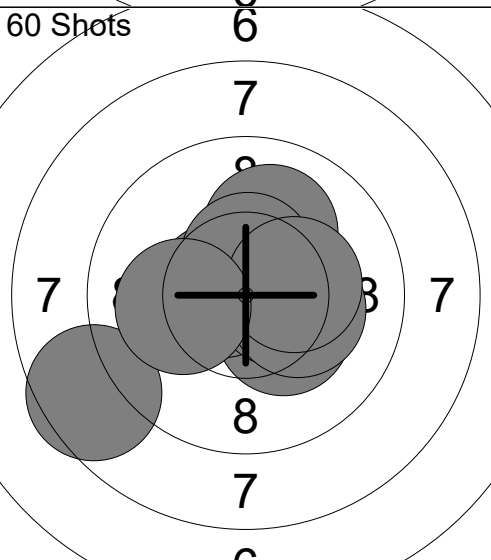
<p>60 Shots</p>  <p style="text-align: center;">6 7 8 7 8 7 8 7</p>	<p>1: 10.3x ←</p> <p>2: 10.4x →</p> <p>3: 10.3x ↗</p> <p>4: 9.6 ←</p> <p>5: 10.5x ←</p> <p>6: 10.1 ↘</p> <p>7: 9.9 ↙</p> <p>8: 10.4x →</p> <p>9: 10.1 ←</p> <p>10: 10.5x ↑</p> <hr/> <p>Series 102.1</p> <hr/> <p style="text-align: center;">102.1</p>	<p>60 Shots</p>  <p style="text-align: center;">6 7 8 7 8 7 8 7</p>	<p>11: 9.9 →</p> <p>12: 10.3x ↓</p> <p>13: 10.2x ↖</p> <p>14: 10.8x ↓</p> <p>15: 10.4x ←</p> <p>16: 9.5 ↖</p> <p>17: 9.8 ↑</p> <p>18: 10.2x →</p> <p>19: 10.4x ↑</p> <p>20: 10.6x ↑</p> <hr/> <p>Series 102.1</p> <hr/> <p style="text-align: center;">204.2</p>
<p>60 Shots</p>  <p style="text-align: center;">6 7 8 7 8 7 8 7</p>	<p>21: 10.2x ⇒</p> <p>22: 9.9 ←</p> <p>23: 10.2x →</p> <p>24: 10.0 ↓</p> <p>25: 10.4x ↑</p> <p>26: 10.2x ↑</p> <p>27: 9.6 ↓</p> <p>28: 10.7x ↓</p> <p>29: 10.3x ↘</p> <p>30: 10.6x ↖</p> <hr/> <p>Series 102.1</p> <hr/> <p style="text-align: center;">306.3</p>	<p>60 Shots</p>  <p style="text-align: center;">6 7 8 7 8 7 8 7</p>	<p>31: 10.1 ↗</p> <p>32: 10.6x ↙</p> <p>33: 10.2x ↙</p> <p>34: 10.3x ↗</p> <p>35: 10.6x →</p> <p>36: 10.1 ↘</p> <p>37: 9.3 ←</p> <p>38: 10.0 ↗</p> <p>39: 10.2x ↑</p> <p>40: 10.5x ↖</p> <hr/> <p>Series 101.9</p> <hr/> <p style="text-align: center;">408.2</p>
<p>60 Shots</p>  <p style="text-align: center;">6 7 8 7 8 7 8 7 6</p>	<p>41: 10.3x ←</p> <p>42: 10.0 ↘</p> <p>43: 10.3x ↓</p> <p>44: 10.5x ↗</p> <p>45: 10.0 ↘</p> <p>46: 10.4x ↘</p> <p>47: 10.2x ←</p> <p>48: 9.0 →</p> <p>49: 9.9 ⇒</p> <p>50: 9.9 ↑</p> <hr/> <p>Series 100.5</p> <hr/> <p style="text-align: center;">508.7</p>	<p>60 Shots</p>  <p style="text-align: center;">6 7 8 7 8 7 8 7 6</p>	<p>51: 10.3x ⇒</p> <p>52: 10.4x ↗</p> <p>53: 8.6 ←</p> <p>54: 10.1 ↑</p> <p>55: 10.6x ←</p> <p>56: 10.5x →</p> <p>57: 10.2x →</p> <p>58: 10.5x ↑</p> <p>59: 10.3x →</p> <p>60: 10.1 ←</p> <hr/> <p>Series 101.6</p> <hr/> <p style="text-align: center;">610.3</p>

Relay 6	Lane 64	HARVEY Mason
-------------------	-------------------	---------------------

1-80	AJ Hotshots	Precision	
------	-------------	-----------	--

31.01.2025	2025 AirNats by X Count	Civilian Marksmanship Program	
------------	-------------------------	-------------------------------	--

Comment	Signature		
---------	-----------	--	--

<p>60 Shots</p> <p style="text-align: center;">6 7 7 7 8 7 7 7 7 7</p>	<p>1: 10.4x →</p> <p>2: 9.9 →</p> <p>3: 9.5 ↖</p> <p>4: 9.9 →</p> <p>5: 10.3x ↙</p> <p>6: 9.6 ←</p> <p>7: 9.7 ↑</p> <p>8: 9.8 ←</p> <p>9: 9.6 ↗</p> <p>10: 9.6 ↗</p> <hr/> <p>Series 98.3</p> <hr/> <p style="text-align: center;">98.3</p>	<p>60 Shots</p> <p style="text-align: center;">6 7 7 7 8 7 7 7 7 7</p>	<p>11: 9.2 ↑</p> <p>12: 10.1 ↗</p> <p>13: 10.0 ↑</p> <p>14: 10.5x ↘</p> <p>15: 9.7 ↗</p> <p>16: 10.9x ↖</p> <p>17: 10.2x ←</p> <p>18: 9.6 ↑</p> <p>19: 10.0 ←</p> <p>20: 10.5x →</p> <hr/> <p>Series 100.7</p> <hr/> <p style="text-align: center;">199.0</p>
<p>60 Shots</p> <p style="text-align: center;">6 7 8 7 8 7 7 7 7 7</p>	<p>21: 10.0 ←</p> <p>22: 10.2x →</p> <p>23: 8.8 ←</p> <p>24: 9.9 →</p> <p>25: 10.0 ↘</p> <p>26: 9.6 ↘</p> <p>27: 9.9 ←</p> <p>28: 10.3x ↑</p> <p>29: 10.2x ←</p> <p>30: 10.7x →</p> <hr/> <p>Series 99.6</p> <hr/> <p style="text-align: center;">298.6</p>	<p>60 Shots</p> <p style="text-align: center;">6 7 7 7 8 7 7 7 7 7</p>	<p>31: 9.6 ←</p> <p>32: 10.0 ←</p> <p>33: 10.1 ↑</p> <p>34: 10.2x ↙</p> <p>35: 10.6x ↘</p> <p>36: 10.3x ←</p> <p>37: 9.9 ↗</p> <p>38: 9.3 ←</p> <p>39: 9.9 ↓</p> <p>40: 10.6x ↙</p> <hr/> <p>Series 100.5</p> <hr/> <p style="text-align: center;">399.1</p>
<p>60 Shots</p> <p style="text-align: center;">6 7 8 8 7 8 7 7 7 7</p>	<p>41: 10.8x ↑</p> <p>42: 8.6 ←</p> <p>43: 8.8 ←</p> <p>44: 10.5x ↘</p> <p>45: 9.9 ↙</p> <p>46: 10.4x ↗</p> <p>47: 10.1 ↓</p> <p>48: 10.5x ↘</p> <p>49: 10.2x ↘</p> <p>50: 9.6 ↖</p> <hr/> <p>Series 99.4</p> <hr/> <p style="text-align: center;">498.5</p>	<p>60 Shots</p> <p style="text-align: center;">6 7 8 7 7 7 7 7 7 7</p>	<p>51: 9.0 →</p> <p>52: 9.7 ←</p> <p>53: 10.7x ↘</p> <p>54: 9.5 →</p> <p>55: 8.7 ←</p> <p>56: 9.9 ↘</p> <p>57: 9.2 →</p> <p>58: 9.2 ←</p> <p>59: 10.2x ↘</p> <p>60: 9.9 ←</p> <hr/> <p>Series 96.0</p> <hr/> <p style="text-align: center;">594.5</p>

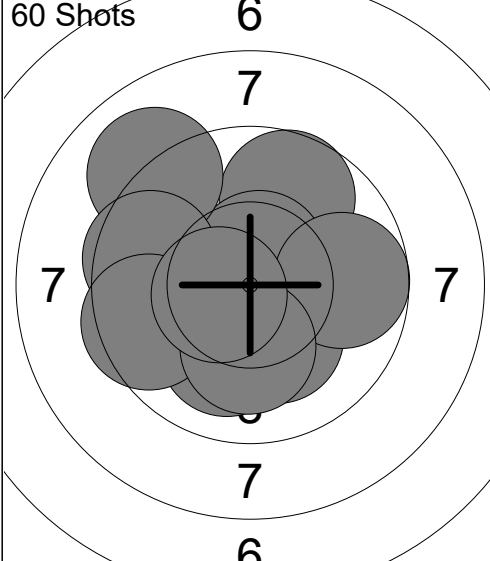
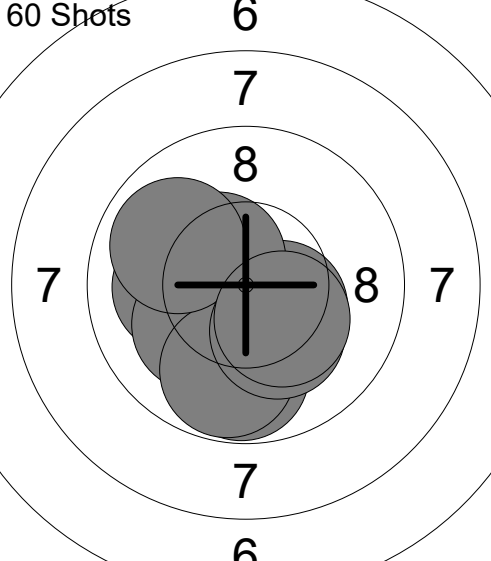
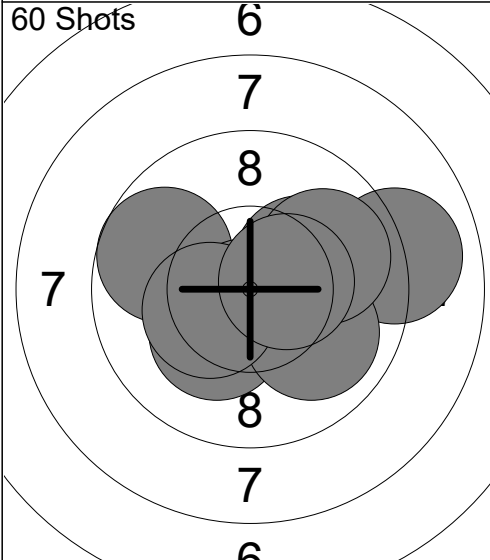
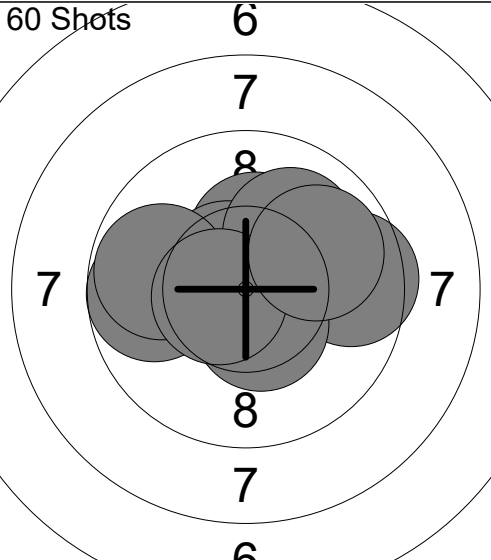
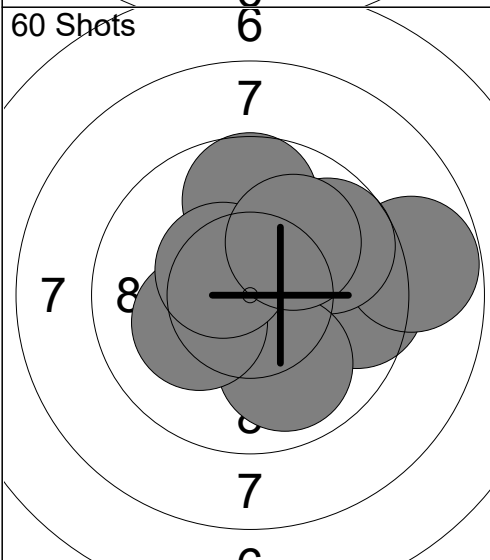
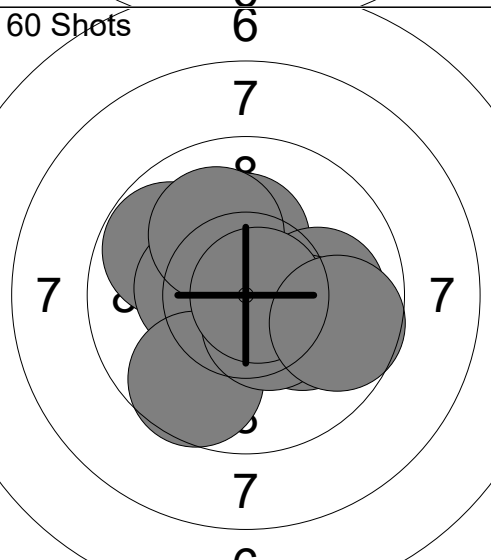
<p>60 Shots</p>  <p style="text-align: center;">6 7 7 7 7</p>	<p>1: 9.7 ↑ 2: 10.6x ↑ 3: 9.0 ↖ 4: 9.6 ← 5: 10.1 ↓ 6: 10.2x ↓ 7: 9.7 → 8: 9.5 ← 9: 10.1 ↓ 10: 10.5x ←</p> <p>Series 99.0 99.0</p>	<p>60 Shots</p>  <p style="text-align: center;">6 7 8 7 7</p>	<p>11: 9.8 ↓ 12: 10.1 ← 13: 10.4x ↘ 14: 10.5x ↙ 15: 10.5x ↖ 16: 10.1 ↙ 17: 9.8 ↓ 18: 9.9 ↖ 19: 10.2x ↓ 20: 10.3x ↘</p> <p>Series 101.6 200.6</p>
<p>60 Shots</p>  <p style="text-align: center;">6 7 8 7 7</p>	<p>21: 9.0 → 22: 9.7 ↖ 23: 10.3x ↙ 24: 10.2x ↗ 25: 10.7x ↓ 26: 10.2x ↙ 27: 10.0 ↘ 28: 9.9 ↗ 29: 10.3x ↙ 30: 10.5x →</p> <p>Series 100.8 301.4</p>	<p>60 Shots</p>  <p style="text-align: center;">6 7 8 7 7</p>	<p>31: 10.6x ↖ 32: 9.7 ← 33: 10.3x ↑ 34: 9.6 → 35: 10.6x ↖ 36: 10.5x ↓ 37: 10.0 ↗ 38: 9.8 ← 39: 10.6x ← 40: 9.9 ↗</p> <p>Series 101.6 403.0</p>
<p>60 Shots</p>  <p style="text-align: center;">6 7 7 8 7 6</p>	<p>41: 10.5x ↑ 42: 9.5 → 43: 10.3x ↑ 44: 8.8 → 45: 9.7 ↑ 46: 9.7 ↗ 47: 9.9 ↓ 48: 10.2x ↙ 49: 10.5x ↖ 50: 10.0 ↗</p> <p>Series 99.1 502.1</p>	<p>60 Shots</p>  <p style="text-align: center;">6 7 7 8 7 6</p>	<p>51: 10.2x ↑ 52: 9.8 ↖ 53: 10.4x ← 54: 9.7 ↓ 55: 10.0 → 56: 10.1 ↘ 57: 10.5x ↓ 58: 10.1 ↑ 59: 10.8x → 60: 9.7 →</p> <p>Series 101.3 603.4</p>

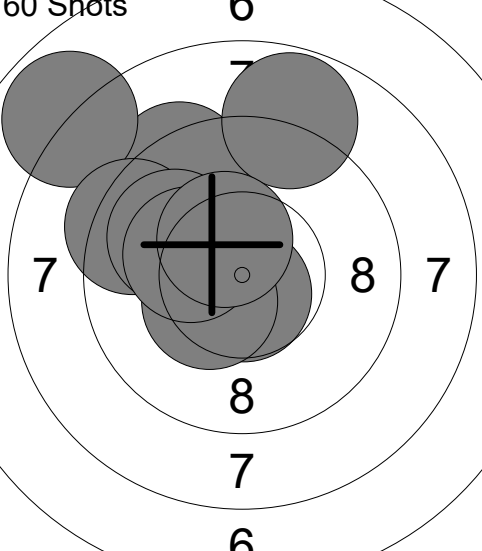
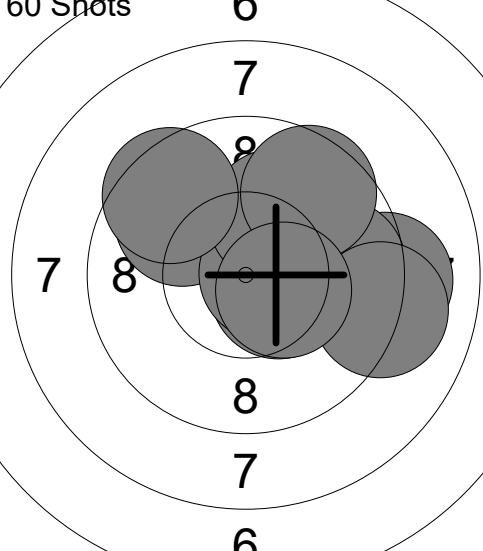
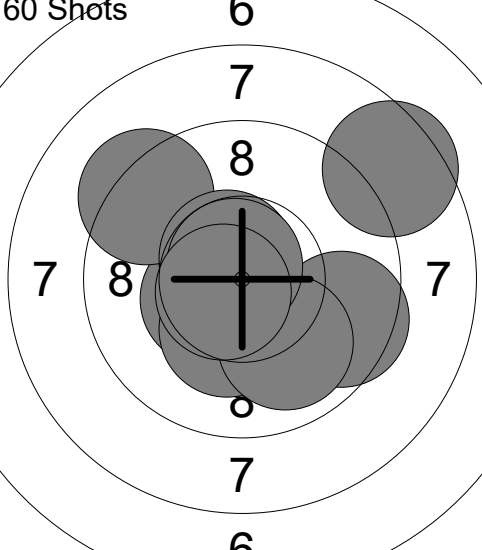
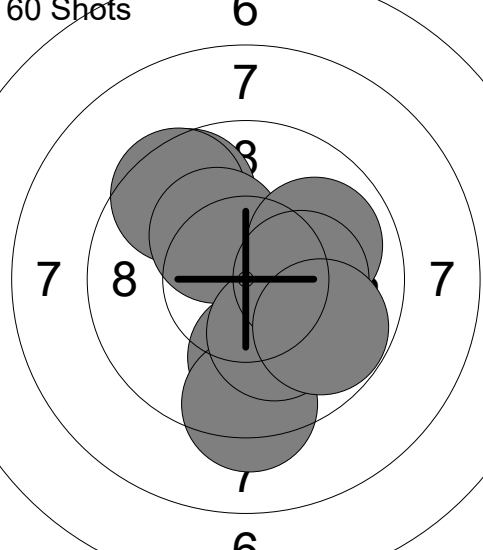
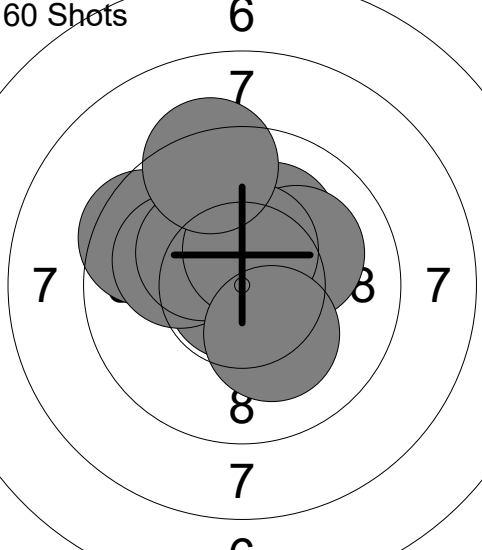
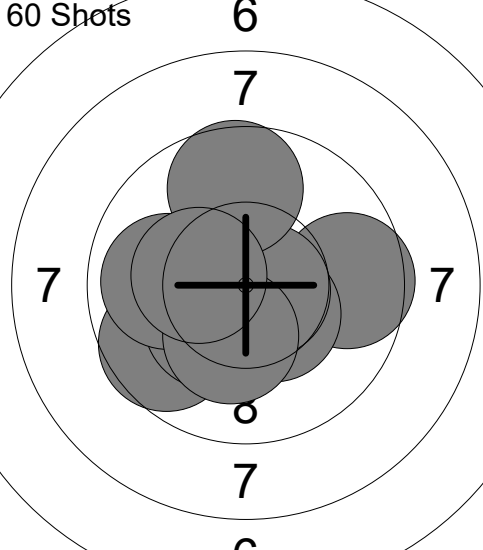
<p>60 Shots</p> 	<p>1: 9.7 ↖ 2: 10.7x ↓ 3: 9.3 ↗ 4: 7.9 ↗ 5: 10.4x ↙ 6: 9.4 ↖ 7: 8.8 ↗ 8: 9.9 ↖ 9: 10.2x ↙ 10: 10.4x ↗</p> <p>Series 96.7</p> <p style="text-align: center;">96.7</p>	<p>60 Shots</p> 	<p>11: 9.1 → 12: 10.5x ⇒ 13: 9.7 → 14: 9.8 ↗ 15: 10.7x → 16: 10.1 ↗ 17: 9.6 ↗ 18: 9.1 → 19: 9.5 ↗ 20: 10.4x ⇒</p> <p>Series 98.5</p> <p style="text-align: center;">195.2</p>
<p>60 Shots</p> 	<p>21: 10.4x ↙ 22: 10.3x ↓ 23: 10.6x ↗ 24: 9.3 ↗ 25: 8.5 ↗ 26: 9.5 ⇒ 27: 10.6x ↗ 28: 9.9 ↓ 29: 10.8x ↗ 30: 10.7x ↙</p> <p>Series 100.6</p> <p style="text-align: center;">295.8</p>	<p>60 Shots</p> 	<p>31: 10.2x → 32: 9.6 ↗ 33: 9.5 ↗ 34: 10.3x ↗ 35: 9.9 ↓ 36: 9.3 ↓ 37: 10.1 ↓ 38: 9.9 ⇒ 39: 10.2x → 40: 9.8 ⇒</p> <p>Series 98.8</p> <p style="text-align: center;">394.6</p>
<p>60 Shots</p> 	<p>41: 10.4x ↗ 42: 10.8x ↙ 43: 10.1 ↗ 44: 10.1 ↗ 45: 9.5 ↖ 46: 10.1 ↖ 47: 10.3x ↗ 48: 10.5x ↗ 49: 9.3 ↗ 50: 10.2x ↓</p> <p>Series 101.3</p> <p style="text-align: center;">495.9</p>	<p>60 Shots</p> 	<p>51: 10.6x ↖ 52: 9.6 ↖ 53: 10.3x ↙ 54: 9.6 → 55: 10.4x ↓ 56: 10.7x ⇒ 57: 9.9 ← 58: 10.2x ↓ 59: 9.7 ↗ 60: 10.3x ↖</p> <p>Series 101.3</p> <p style="text-align: center;">597.2</p>

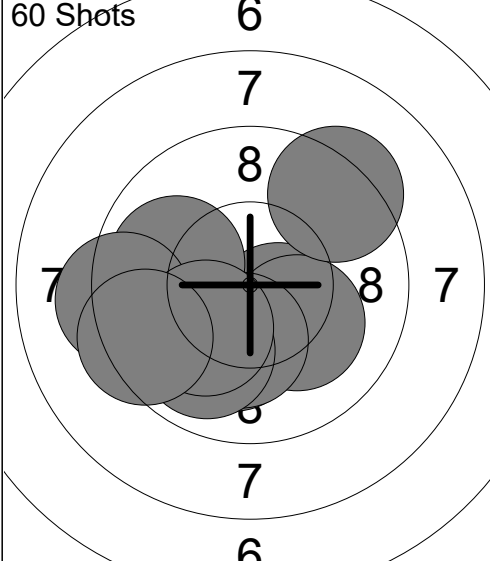
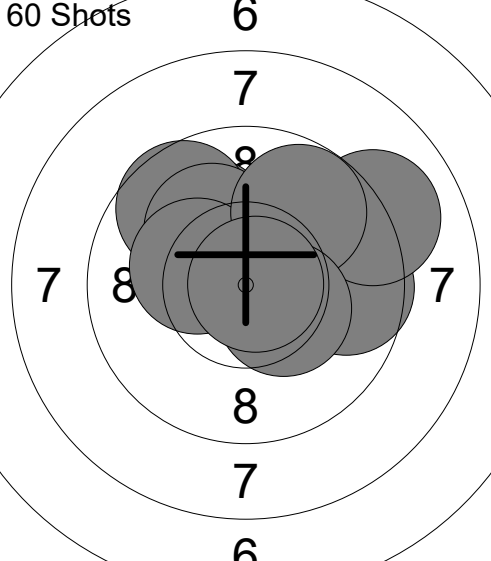
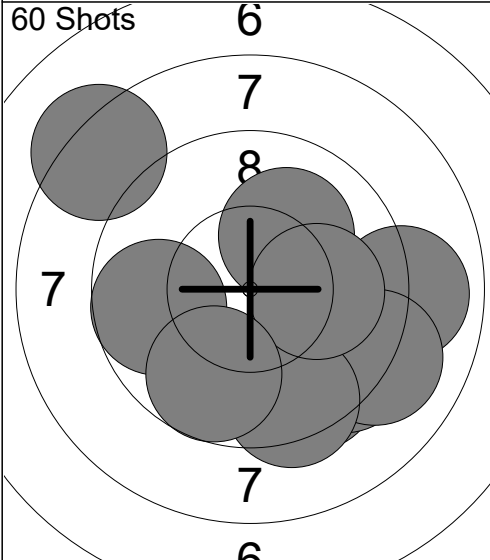
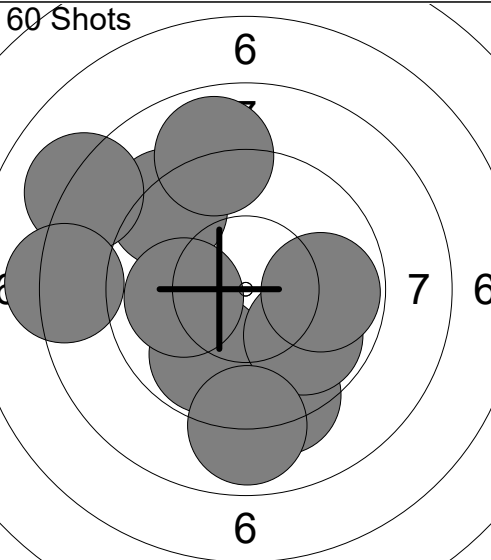
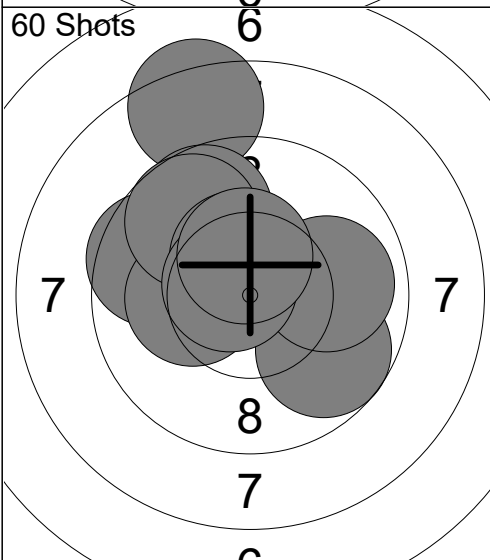
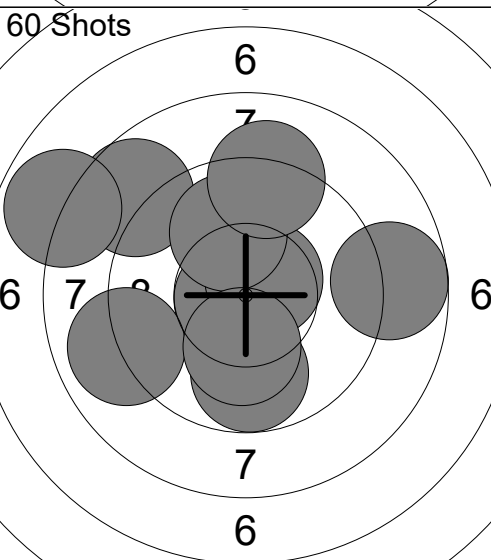
<p>60 Shots</p>  <p style="text-align: center;">6 7 8 7 7</p>	<p>1: 10.1 ↓ 2: 10.4x ↘ 3: 10.2x ↘ 4: 10.2x ↓ 5: 9.9 ← 6: 9.3 ↗ 7: 9.3 ← 8: 9.9 ↓ 9: 10.1 ↓ 10: 9.4 ←</p> <p>Series 98.8 98.8</p>	<p>60 Shots</p>  <p style="text-align: center;">6 7 8 7 7</p>	<p>11: 10.0 ↗ 12: 9.7 ↗ 13: 10.4x ↗ 14: 10.1 ↗ 15: 10.3x ← 16: 9.6 → 17: 9.0 ↗ 18: 9.8 ↗ 19: 10.4x ↘ 20: 10.8x →</p> <p>Series 100.1 198.9</p>
<p>60 Shots</p>  <p style="text-align: center;">6 7 8 7 7</p>	<p>21: 9.5 ↓ 22: 9.7 ← 23: 8.9 → 24: 9.4 ↘ 25: 10.1 ↗ 26: 9.1 ↘ 27: 8.3 ↗ 28: 9.4 ↓ 29: 10.1 → 30: 9.7 ↓</p> <p>Series 94.2 293.1</p>	<p>60 Shots</p>  <p style="text-align: center;">6 7 7 7 6</p>	<p>31: 9.3 ↓ 32: 9.3 ↗ 33: 9.8 ↓ 34: 8.9 ↑ 35: 9.8 ↘ 36: 9.8 → 37: 8.1 ↗ 38: 8.9 ↓ 39: 10.0 ← 40: 8.2 ←</p> <p>Series 92.1 385.2</p>
<p>60 Shots</p>  <p style="text-align: center;">6 7 8 7 6</p>	<p>41: 9.6 ← 42: 8.4 ↑ 43: 9.7 ↘ 44: 10.2x ← 45: 9.9 → 46: 9.7 ↗ 47: 9.7 ↗ 48: 10.4x ↑ 49: 10.6x ← 50: 10.4x ↑</p> <p>Series 98.6 483.8</p>	<p>60 Shots</p>  <p style="text-align: center;">6 7 7 7 6</p>	<p>51: 10.7x ← 52: 8.7 ↗ 53: 8.7 → 54: 9.8 ↓ 55: 10.6x ↗ 56: 10.0 ↑ 57: 9.0 ← 58: 9.2 ↑ 59: 10.2x ↓ 60: 7.9 ←</p> <p>Series 94.8 578.6</p>

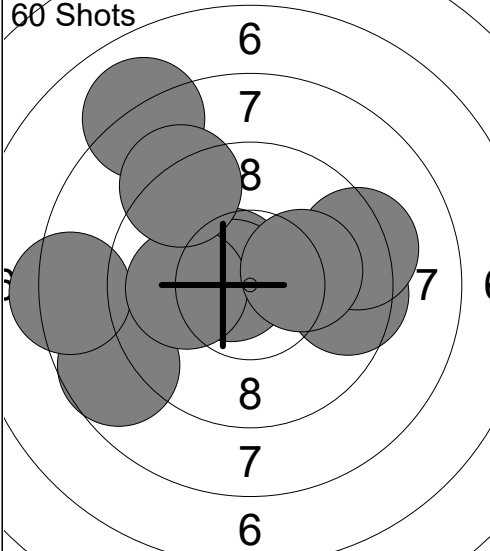
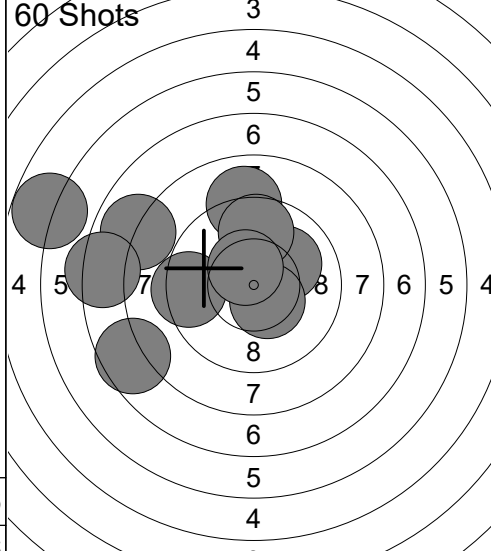
<p>60 Shots</p>  <p style="text-align: center;">6 7 8 7 8 7 6</p> <p style="text-align: right;">Series 94.6</p>	<p>1: 10.6x ↖</p> <p>2: 10.7x ←</p> <p>3: 8.1 ↗</p> <p>4: 9.5 →</p> <p>5: 8.7 ←</p> <p>6: 9.3 →</p> <p>7: 8.3 ←</p> <p>8: 10.0 ←</p> <p>9: 10.2x →</p> <p>10: 9.2 ↗</p> <hr/> <p>Series 94.6</p>	<p>60 Shots</p>  <p style="text-align: center;">3 4 5 6 7 8 7 6 5 4</p> <p style="text-align: right;">Series 87.8</p>
94.6		11: 9.4 ←
		12: 7.9 ↖
		13: 10.1 ↗
		14: 10.5x ↘
		15: 9.0 ↑
		16: 7.3 ←
		17: 9.7 ↑
		18: 7.6 ↖
		19: 10.5x ↗
		20: 5.8 ↖
		Series 182.4

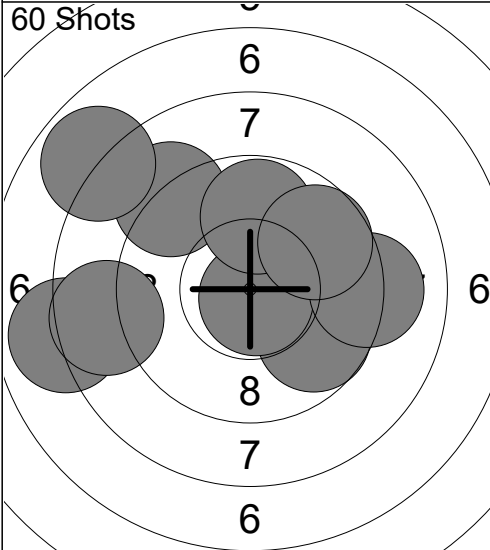
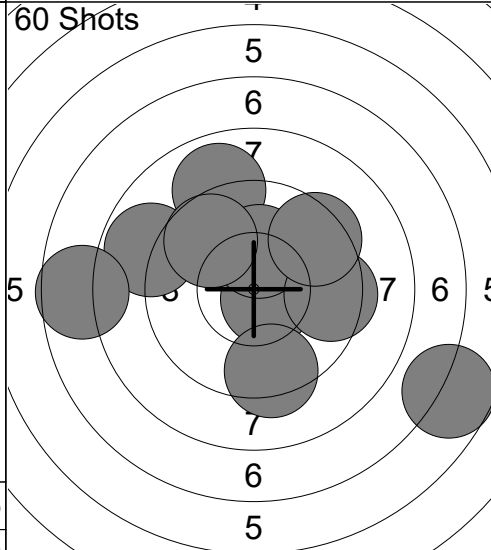
<p>60 Shots</p>  <p style="text-align: center;">6 7 8 7 6</p> <p style="text-align: right;">Series 92.6</p>	<p>21: 9.8 →</p> <p>22: 9.7 ↘</p> <p>23: 9.1 ↗</p> <p>24: 10.8x ↘</p> <p>25: 9.8 ↑</p> <p>26: 7.9 ↗</p> <p>27: 8.0 ←</p> <p>28: 8.7 ←</p> <p>29: 9.1 →</p> <p>30: 9.7 ↗</p> <hr/> <p>Series 92.6</p>	<p>60 Shots</p>  <p style="text-align: center;">5 6 7 6 5</p> <p style="text-align: right;">Series 90.7</p>
275.0		31: 6.7 ↘
		32: 8.9 ↑
		33: 10.6x ↘
		34: 10.2x ↑
		35: 8.8 ↖
		36: 9.3 ↓
		37: 9.5 →
		38: 9.4 ↗
		39: 9.7 ↗
		40: 7.6 ←
		Series 365.7

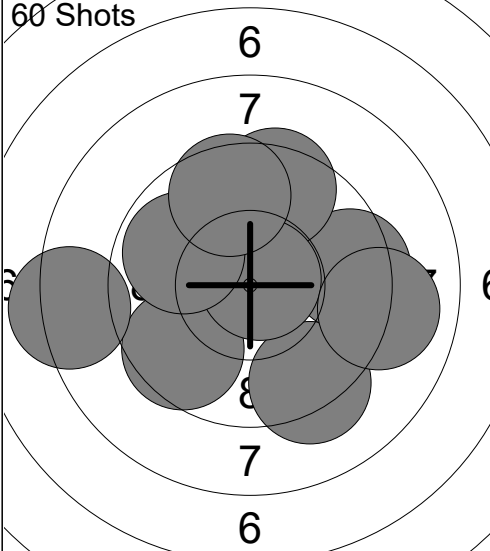
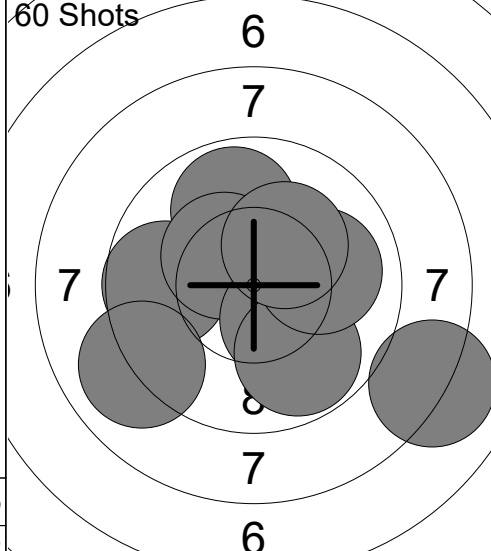
<p>60 Shots</p>  <p style="text-align: center;">6 7 8 7 6</p> <p style="text-align: right;">Series 95.5</p>	<p>41: 9.3 ↘</p> <p>42: 9.5 →</p> <p>43: 10.0 ↖</p> <p>44: 9.6 ↖</p> <p>45: 8.3 ←</p> <p>46: 9.5 ↑</p> <p>47: 10.8x ↗</p> <p>48: 9.9 ↖</p> <p>49: 9.0 →</p> <p>50: 9.6 ↑</p> <hr/> <p>Series 95.5</p>	<p>60 Shots</p>  <p style="text-align: center;">6 7 8 7 6</p> <p style="text-align: right;">Series 97.8</p>
461.2		51: 10.4x ↗
		52: 9.9 ↑
		53: 9.7 ←
		54: 10.4x ↖
		55: 10.3x ↘
		56: 9.8 ↘
		57: 10.0 →
		58: 9.0 ↖
		59: 10.2x ↗
		60: 8.1 ↘
		Series 559.0

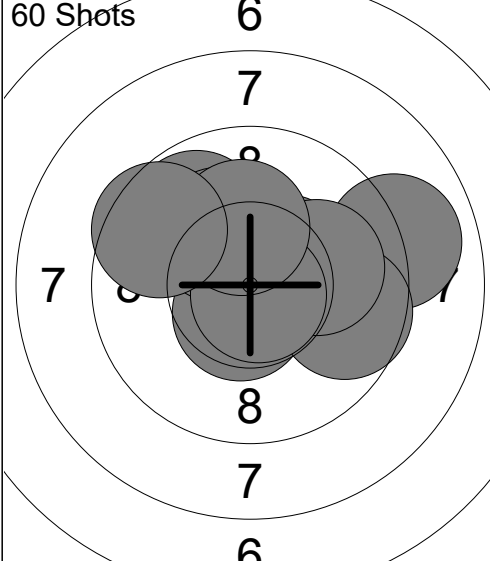
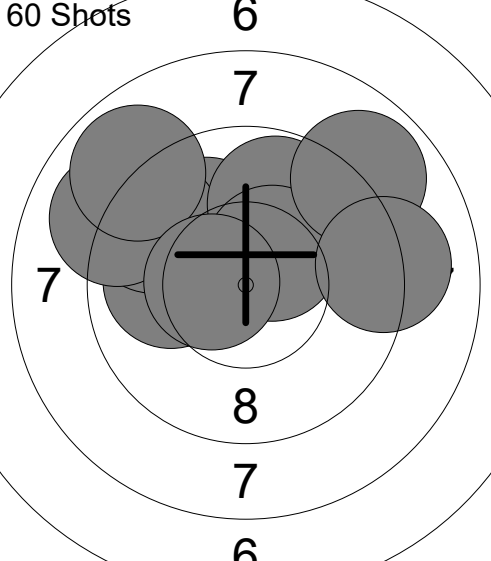
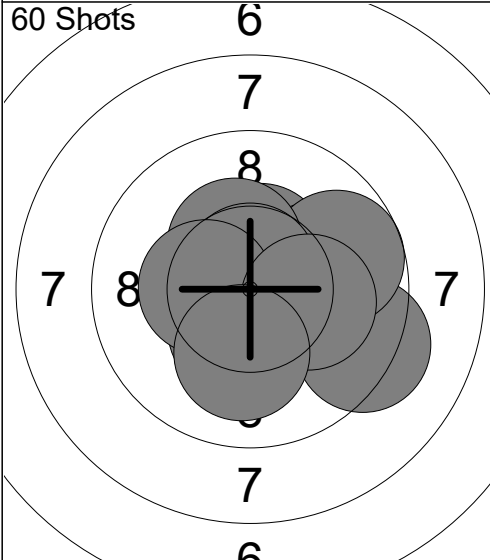
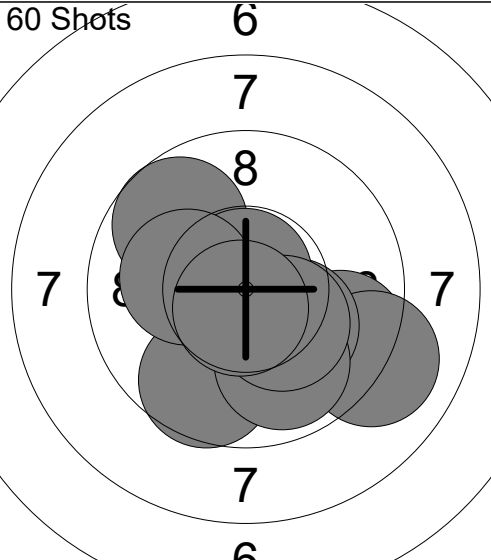
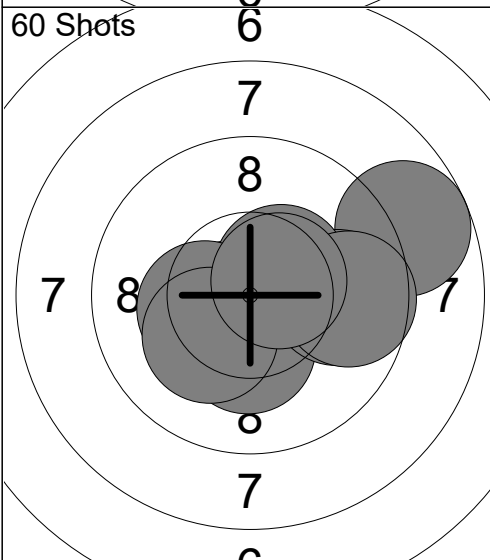
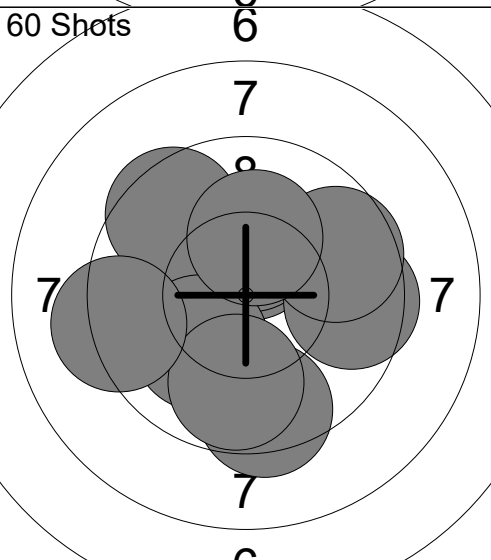
60 Shots 	1: 9.0 → 2: 9.8 ↗ 3: 10.4x ↗ 4: 10.6x ↓ 5: 9.6 → 6: 10.0 → 7: 10.2x ↗ 8: 10.8x ↓ 9: 10.2x ↑ 10: 9.5 ↖ <hr/> Series 100.1 100.1	60 Shots 	11: 10.0 ↗ 12: 10.0 ← 13: 9.5 ↖ 14: 9.8 ↑ 15: 9.0 ↖ 16: 8.9 ↗ 17: 10.4x ↗ 18: 8.9 ↗ 19: 9.1 → 20: 10.5x ← <hr/> Series 96.1 196.2
60 Shots 	21: 10.4x ↑ 22: 10.4x ↓ 23: 9.3 → 24: 10.0 → 25: 9.7 → 26: 10.3x ↑ 27: 10.7x ↑ 28: 10.4x ← 29: 10.2x → 30: 10.1 ↓ <hr/> Series 101.5 297.7	60 Shots 	31: 9.6 ↓ 32: 9.7 ↗ 33: 9.5 → 34: 9.1 → 35: 10.2x ↓ 36: 10.8x ↑ 37: 9.9 ↓ 38: 10.3x ↓ 39: 10.2x ← 40: 10.7x ↓ <hr/> Series 100.0 397.7
60 Shots 	41: 8.7 → 42: 10.7x ↖ 43: 10.4x ↖ 44: 10.3x ↓ 45: 9.8 → 46: 10.4x ↗ 47: 9.6 → 48: 10.3x ← 49: 10.2x ↖ 50: 10.5x ↗ <hr/> Series 100.9 498.6	60 Shots 	51: 10.4x ↑ 52: 10.3x ↑ 53: 9.5 ↖ 54: 9.5 → 55: 9.4 ↓ 56: 9.6 → 57: 10.1 ↖ 58: 9.8 ↓ 59: 10.2x ↑ 60: 9.2 ← <hr/> Series 98.0 596.6

Relay 6	Lane 71	IRIZARRY Jagrieliz	
--------------------------	--------------------------	---------------------------	--

1-80	SMA Rifle	Precision	
------	-----------	-----------	--

31.01.2025	2025 AirNats by X Count	Civilian Marksmanship Program	
------------	-------------------------	-------------------------------	--

Comment	Signature		
---------	-----------	--	--

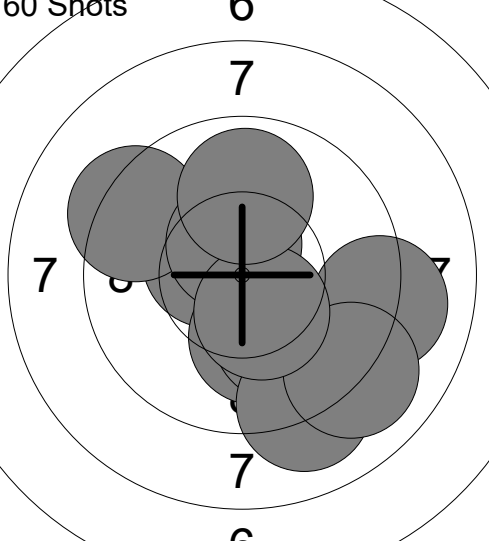
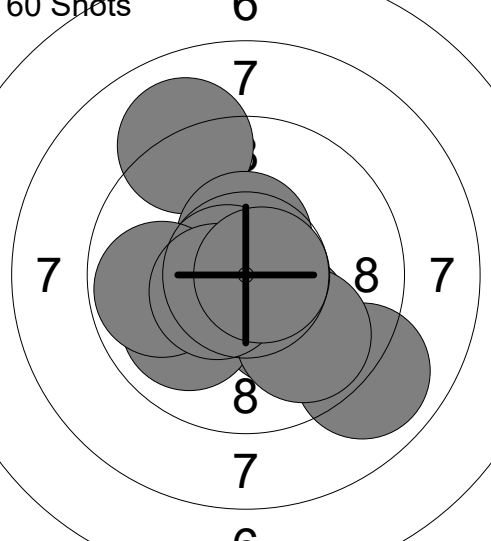
<p>60 Shots 6</p> 	<p>1: 10.5x ↖ 2: 10.1 ↓ 3: 10.0 ↓ 4: 9.3 ↗ 5: 9.1 → 6: 9.1 ↓ 7: 10.5x ↑ 8: 9.0 ↓ 9: 10.4x ↓ 10: 9.9 ↑</p> <p>Series 97.9</p> <p style="text-align: center;">97.9</p>	<p>60 Shots 6</p> 	<p>11: 9.1 ↗ 12: 10.5x ↑ 13: 9.0 ↘ 14: 10.2x ↓ 15: 10.0 ↙ 16: 9.8 ↘ 17: 10.7x ← 18: 9.8 ← 19: 10.5x ↙ 20: 10.7x →</p> <p>Series 100.3</p> <p style="text-align: center;">198.2</p>
---	--	---	--

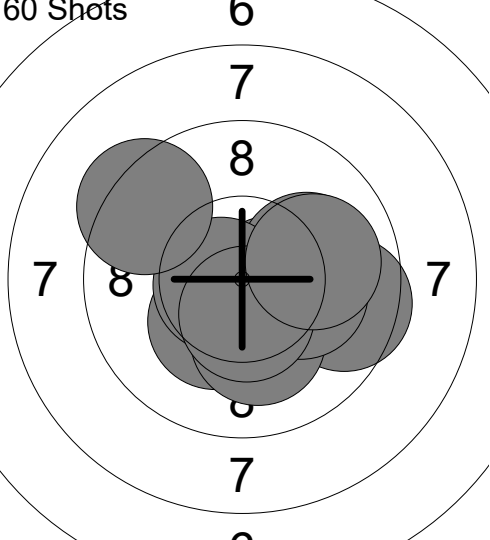
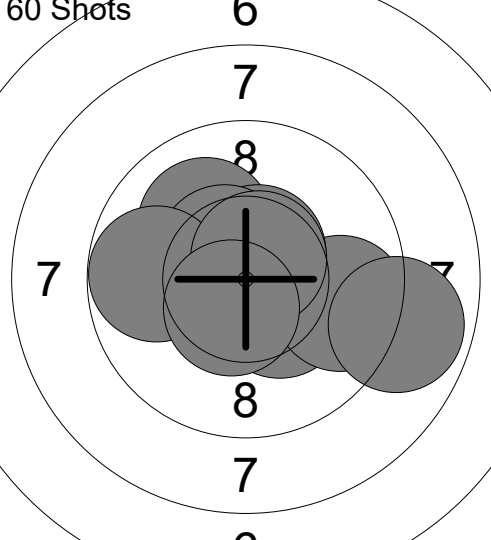
<p>60 Shots 6</p> 	<p>21: 10.3x ↓ 22: 10.5x → 23: 9.6 → 24: 10.1 → 25: 10.2x ↓ 26: 10.2x → 27: 10.7x ← 28: 10.5x ↓ 29: 9.3 ↗ 30: 10.0 →</p> <p>Series 101.4</p> <p style="text-align: center;">299.6</p>	<p>60 Shots 6</p> 	<p>31: 10.7x ← 32: 10.3x ↘ 33: 10.1 ↗ 34: 9.7 → 35: 10.6x ↑ 36: 10.5x ↗ 37: 9.8 ← 38: 10.6x ↗ 39: 8.9 → 40: 10.5x ↓</p> <p>Series 101.7</p> <p style="text-align: center;">401.3</p>
--	---	--	--

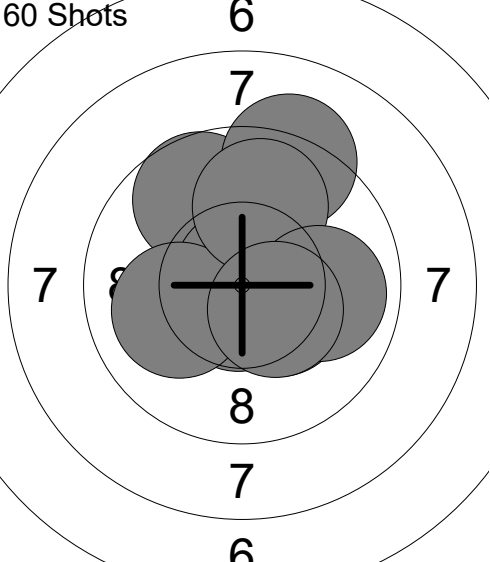
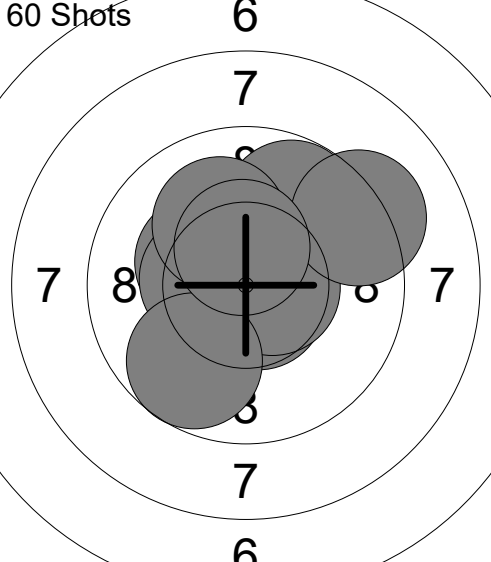
<p>60 Shots 6</p> 	<p>41: 10.7x ↓ 42: 10.2x → 43: 10.4x ↘ 44: 9.7 ↗ 45: 10.8x ↑ 46: 9.2 ↗ 47: 10.1 ← 48: 9.9 ↑ 49: 9.9 → 50: 10.4x ↘</p> <p>Series 101.3</p> <p style="text-align: center;">502.6</p>	<p>60 Shots 6</p> 	<p>51: 10.7x ↘ 52: 10.3x ↖ 53: 10.7x ← 54: 9.8 ↗ 55: 10.4x ← 56: 10.1 ↗ 57: 10.6x → 58: 9.2 ↗ 59: 9.7 ↓ 60: 10.5x ↑</p> <p>Series 102.0</p> <p style="text-align: center;">604.6</p>
---	--	---	--

<p>60 Shots</p> <p style="text-align: center;">5 6 7 8 8 7 6 5</p>	<p>1: 9.8 →</p> <p>2: 8.9 ↓</p> <p>3: 10.5x ←</p> <p>4: 7.7 →</p> <p>5: 9.8 ↓</p> <p>6: 8.4 ↙</p> <p>7: 8.3 ↗</p> <p>8: 9.2 ↗</p> <p>9: 9.9 ←</p> <p>10: 10.1 →</p> <hr/> <p>Series 92.6</p> <hr/> <p style="text-align: center;">92.6</p>	<p>60 Shots</p> <p style="text-align: center;">6 7 8 7 6 5</p>	<p>11: 9.9 ←</p> <p>12: 8.8 →</p> <p>13: 10.3x ↙</p> <p>14: 10.8x ↓</p> <p>15: 8.5 →</p> <p>16: 8.2 ↑</p> <p>17: 9.5 ↑</p> <p>18: 10.2x ↗</p> <p>19: 10.2x ↗</p> <p>20: 10.1 →</p> <hr/> <p>Series 96.5</p> <hr/> <p style="text-align: center;">189.1</p>
<p>60 Shots</p> <p style="text-align: center;">5 6 7 6 7 6 5</p>	<p>21: 8.8 →</p> <p>22: 7.4 →</p> <p>23: 9.9 ↑</p> <p>24: 8.2 →</p> <p>25: 9.8 ↑</p> <p>26: 9.8 ↗</p> <p>27: 9.3 ↓</p> <p>28: 9.0 ↓</p> <p>29: 10.8x ↙</p> <p>30: 10.0 ←</p> <hr/> <p>Series 93.0</p> <hr/> <p style="text-align: center;">282.1</p>	<p>60 Shots</p> <p style="text-align: center;">6 7 7 6 7 6 5</p>	<p>31: 9.4 →</p> <p>32: 9.9 ↓</p> <p>33: 9.7 ↑</p> <p>34: 10.6x ↑</p> <p>35: 9.7 ←</p> <p>36: 9.9 ↗</p> <p>37: 10.1 ←</p> <p>38: 8.6 →</p> <p>39: 9.2 →</p> <p>40: 8.9 ↗</p> <hr/> <p>Series 96.0</p> <hr/> <p style="text-align: center;">378.1</p>
<p>60 Shots</p> <p style="text-align: center;">6 7 7 6 7 6 5</p>	<p>41: 10.0 ↓</p> <p>42: 8.7 →</p> <p>43: 9.8 →</p> <p>44: 9.9 ↑</p> <p>45: 10.1 ←</p> <p>46: 9.9 ↑</p> <p>47: 8.5 ↓</p> <p>48: 10.4x ←</p> <p>49: 10.4x ↑</p> <p>50: 8.9 ↗</p> <hr/> <p>Series 96.6</p> <hr/> <p style="text-align: center;">474.7</p>	<p>60 Shots</p> <p style="text-align: center;">6 7 8 7 6 5</p>	<p>51: 10.4x ↑</p> <p>52: 10.0 ↓</p> <p>53: 10.3x ←</p> <p>54: 8.5 ←</p> <p>55: 10.3x ↓</p> <p>56: 9.6 ↗</p> <p>57: 8.0 →</p> <p>58: 10.1 ↙</p> <p>59: 8.3 →</p> <p>60: 10.6x ↑</p> <hr/> <p>Series 96.1</p> <hr/> <p style="text-align: center;">570.8</p>

<p>60 Shots</p> <p style="text-align: center;">6 7 8 7 7 8 7 7 7 7</p>	<p>1: 9.9 ↘ 2: 10.2x ↘ 3: 9.9 ↘ 4: 9.0 ↗ 5: 9.7 ↘ 6: 10.1 ↙ 7: 10.0 ↘ 8: 8.8 ↘ 9: 9.9 → 10: 10.5x ↘</p> <p>Series 98.0</p>	<p>60 Shots</p> <p style="text-align: center;">6 7 8 7 7 8 7 8 7 7</p>	<p>11: 9.3 ↗ 12: 10.0 ↘ 13: 10.4x ↗ 14: 10.4x ↘ 15: 10.2x ← 16: 9.7 ↘ 17: 10.5x ↘ 18: 10.2x ↗ 19: 9.0 ↙ 20: 9.9 ↘</p> <p>Series 99.6</p>
	98.0		197.6
<p>60 Shots</p> <p style="text-align: center;">6 5 6 7 8 6 7 7 6 6</p>	<p>21: 9.6 ↘ 22: 7.7 → 23: 10.0 ↙ 24: 9.5 → 25: 10.2x ↗ 26: 9.9 ↙ 27: 10.3x ↘ 28: 10.8x ↗ 29: 9.7 ↘ 30: 9.5 ←</p> <p>Series 97.2</p>	<p>60 Shots</p> <p style="text-align: center;">6 6 7 8 7 7 7 7 7 7</p>	<p>31: 10.6x ↘ 32: 9.8 ← 33: 10.3x ↑ 34: 9.5 ↘ 35: 10.3x ↗ 36: 9.7 ↗ 37: 10.0 ↙ 38: 10.4x ← 39: 9.3 ↙ 40: 9.7 ←</p> <p>Series 99.6</p>
	294.8		394.4
<p>60 Shots</p> <p style="text-align: center;">6 7 8 7 7 8 7 7 7 7</p>	<p>41: 10.4x ↙ 42: 8.2 ← 43: 9.7 ↙ 44: 10.1 ↘ 45: 8.9 → 46: 10.5x ↘ 47: 10.2x → 48: 10.6x ↘ 49: 10.8x ↘ 50: 10.4x ↘</p> <p>Series 99.8</p>	<p>60 Shots</p> <p style="text-align: center;">6 6 7 8 7 7 7 7 7 7</p>	<p>51: 9.6 ↗ 52: 10.5x ↘ 53: 10.8x ↙ 54: 8.9 → 55: 10.4x ↘ 56: 10.4x ↙ 57: 10.5x ↗ 58: 10.5x → 59: 9.8 ↑ 60: 9.1 ←</p> <p>Series 100.5</p>
	494.2		594.7

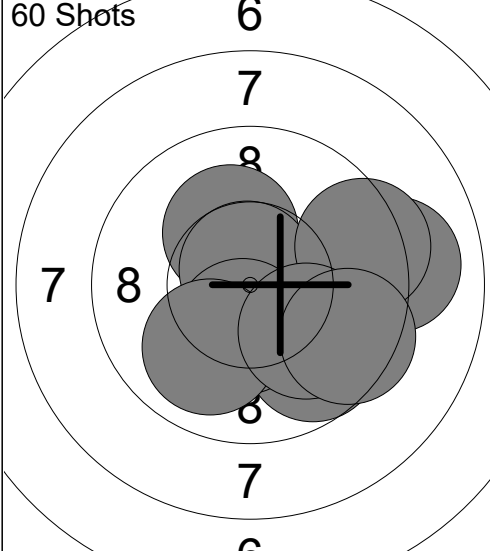
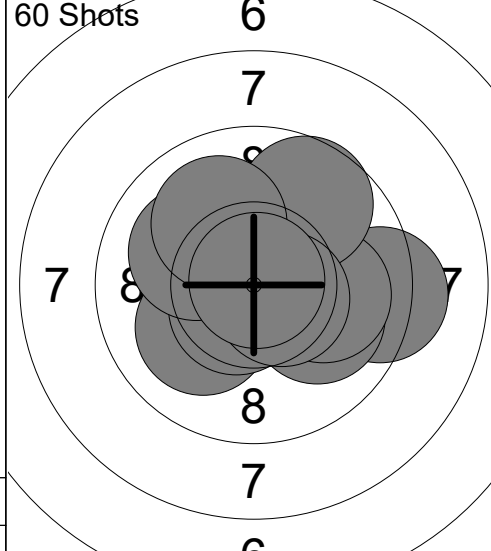
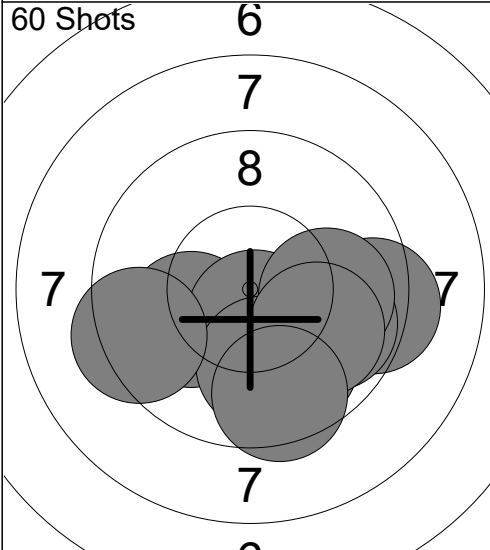
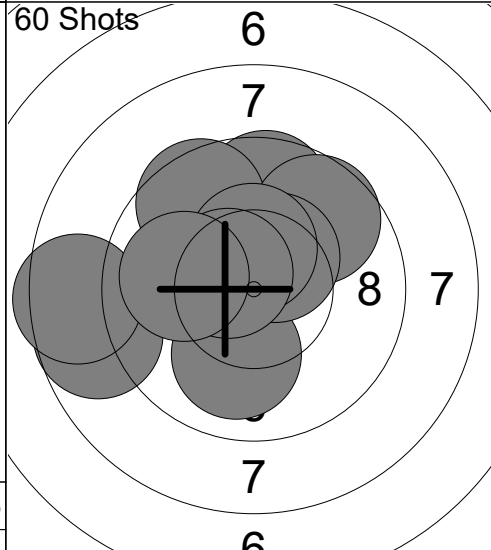
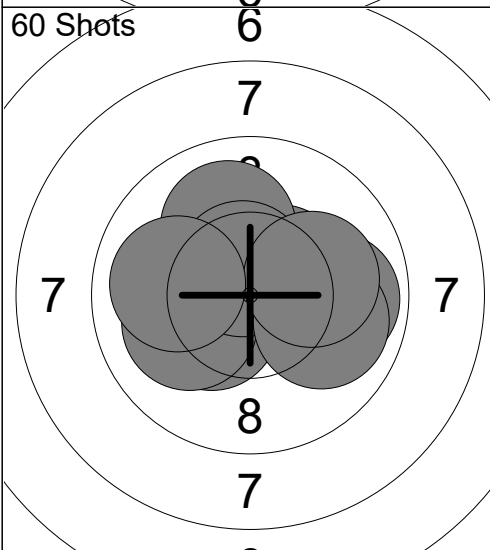
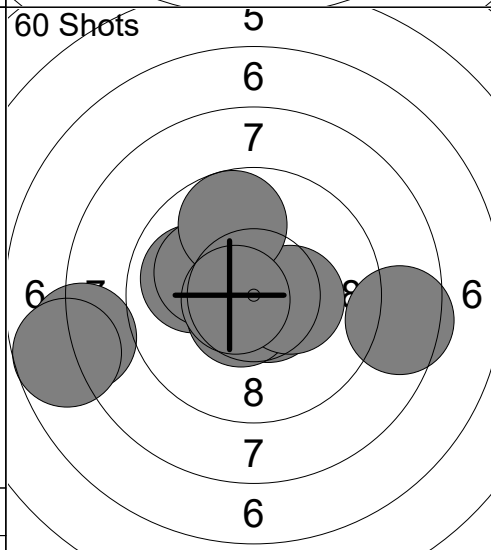
<p>60 Shots</p> 	<p>1: 10.2x ↑ 2: 10.2x → 3: 9.7 ↓ 4: 10.7x ↑ 5: 9.0 → 6: 10.4x ↓ 7: 10.0 ↓ 8: 9.4 → 9: 10.0 ↓ 10: 9.5 →</p> <p>Series 99.1</p>	<p>60 Shots</p> 	<p>11: 9.3 → 12: 10.0 → 13: 10.1 ↙ 14: 10.0 → 15: 10.6x ↙ 16: 9.7 ↗ 17: 10.1 ↖ 18: 10.0 ↗ 19: 10.5x → 20: 10.9x ↗</p> <p>Series 101.2</p>
	99.1		200.3
<p>60 Shots</p> 	<p>21: 9.3 → 22: 10.1 ↖ 23: 9.9 ↓ 24: 10.6x ↓ 25: 9.8 → 26: 9.9 ↓ 27: 9.9 → 28: 9.4 ↖ 29: 9.9 → 30: 9.5 ↓</p> <p>Series 98.3</p>	<p>60 Shots</p> 	<p>31: 9.6 ↑ 32: 9.6 ↖ 33: 9.7 ↗ 34: 8.7 ↖ 35: 8.5 ↖ 36: 10.0 ↓ 37: 10.4x ↗ 38: 10.4x ↑ 39: 10.5x ↖ 40: 10.0 ↖</p> <p>Series 97.4</p>
	298.6		396.0
<p>60 Shots</p> 	<p>41: 10.7x ↑ 42: 10.3x ↖ 43: 10.5x ↗ 44: 10.1 ↖ 45: 9.9 → 46: 10.0 ↑ 47: 10.6x ↑ 48: 9.9 → 49: 10.1 → 50: 10.0 ↖</p> <p>Series 102.1</p>	<p>60 Shots</p> 	<p>51: 9.9 ↖ 52: 8.0 ↖ 53: 10.6x ↘ 54: 10.6x ↙ 55: 10.3x → 56: 10.1 ↖ 57: 8.5 → 58: 9.7 ↑ 59: 7.7 ↖ 60: 10.6x ↖</p> <p>Series 96.0</p>
	498.1		594.1

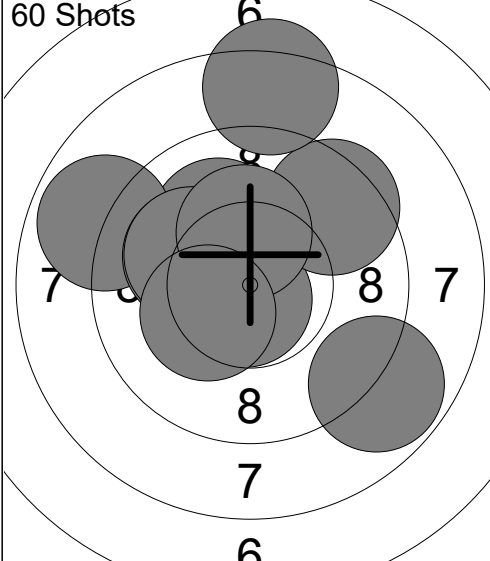
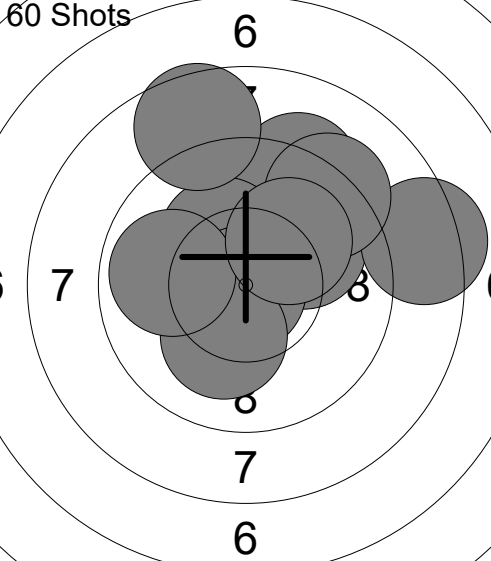
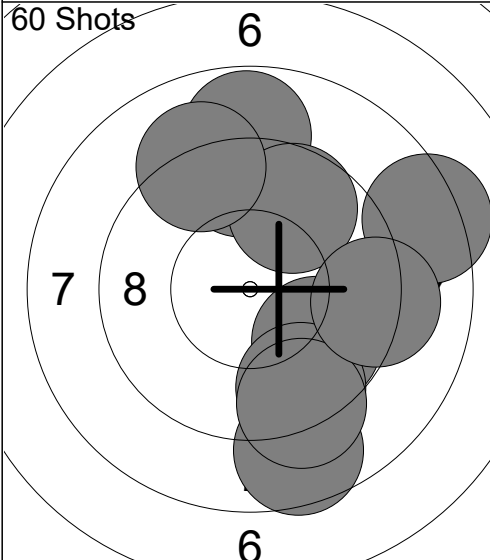
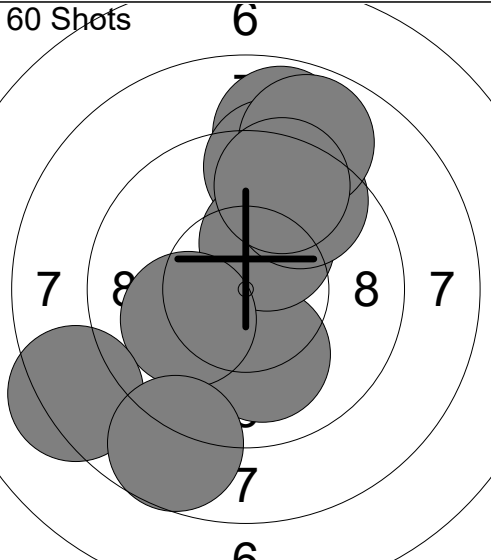
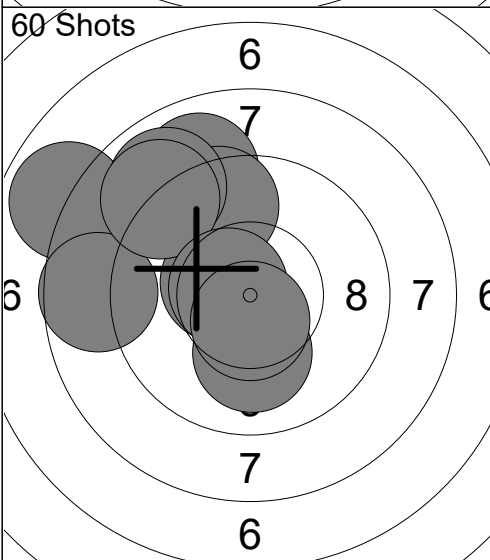
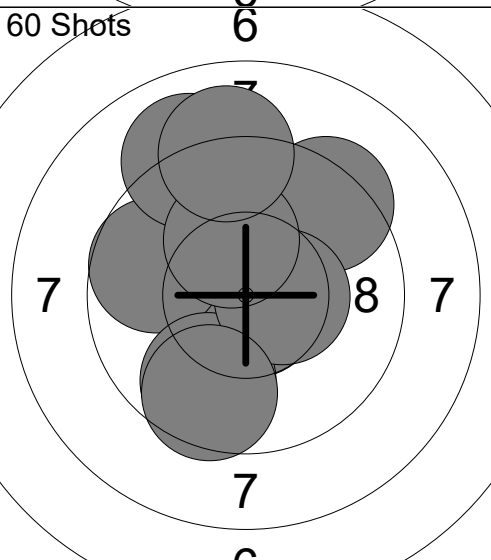
<p>60 Shots</p>  <p style="text-align: center;">6 8 7 8 7 8 7</p>	<p>1: 10.1 ↗ 2: 10.7x ↓ 3: 8.9 ↖ 4: 10.1 ↖ 5: 9.5 ↗ 6: 10.1 ↖ 7: 10.2x ↑ 8: 8.8 ↘ 9: 8.3 ↑ 10: 10.3x ↙</p> <p>Series 97.0 97.0</p>	<p>60 Shots</p>  <p style="text-align: center;">6 7 8 7</p>	<p>11: 10.0 ↗ 12: 8.3 → 13: 9.2 ↑ 14: 10.2x ↖ 15: 9.2 ↗ 16: 10.9x ↓ 17: 10.2x ↓ 18: 8.6 ↑ 19: 9.9 ← 20: 10.1 ↗</p> <p>Series 96.6 193.6</p>
<p>60 Shots</p>  <p style="text-align: center;">6 7 8 6</p>	<p>21: 9.3 ↑ 22: 9.8 ↘ 23: 9.4 ↘ 24: 8.6 ↘ 25: 8.8 ↑ 26: 9.2 ↘ 27: 9.7 ↗ 28: 8.3 → 29: 9.2 → 30: 9.1 ↑</p> <p>Series 91.4 285.0</p>	<p>60 Shots</p>  <p style="text-align: center;">6 7 8 8 7 7</p>	<p>31: 8.8 ↑ 32: 10.1 ↓ 33: 9.3 ↑ 34: 10.3x ↑ 35: 9.6 ↑ 36: 10.1 ← 37: 8.8 ↑ 38: 9.5 ↑ 39: 8.3 ← 40: 8.7 ↓</p> <p>Series 93.5 378.5</p>
<p>60 Shots</p>  <p style="text-align: center;">6 7 6 8 7 6 7 6</p>	<p>41: 10.5x ← 42: 7.9 ↖ 43: 8.7 ← 44: 9.0 ↑ 45: 9.5 ↑ 46: 10.1 ↓ 47: 8.9 ↗ 48: 9.0 ↗ 49: 10.6x ← 50: 10.6x ↓</p> <p>Series 94.8 473.3</p>	<p>60 Shots</p>  <p style="text-align: center;">6 7 7 8 7 7 6</p>	<p>51: 10.4x ↖ 52: 10.7x ↓ 53: 9.7 ← 54: 9.0 ↑ 55: 9.3 ↗ 56: 9.7 ↓ 57: 10.5x → 58: 10.2x ↑ 59: 9.6 ↓ 60: 9.1 ↑</p> <p>Series 98.2 571.5</p>

<p>60 Shots</p>	<p>1: 10.1 ↖ 2: 10.6x ↗ 3: 10.6x ↑ 4: 9.9 ↖ 5: 9.7 ↗ 6: 10.8x ← 7: 10.2x → 8: 10.0 ← 9: 9.5 ↖ 10: 10.4x ↑</p> <p>Series 101.8 101.8</p>	<p>60 Shots</p>	<p>11: 10.0 ↑ 12: 10.1 ↖ 13: 10.6x ← 14: 10.1 → 15: 10.6x ↙ 16: 10.2x ← 17: 10.7x ↑ 18: 10.8x ↗ 19: 10.6x ↓ 20: 10.0 ←</p> <p>Series 103.7 205.5</p>
<p>60 Shots</p>	<p>21: 10.4x ↑ 22: 10.5x ↖ 23: 10.6x ↑ 24: 10.5x → 25: 10.6x ↖ 26: 10.2x ← 27: 10.0 ↗ 28: 10.3x ↑ 29: 10.7x ← 30: 10.2x ←</p> <p>Series 104.0 309.5</p>	<p>60 Shots</p>	<p>31: 10.5x → 32: 10.4x ↖ 33: 9.8 → 34: 10.1 → 35: 10.1 → 36: 10.2x ↘ 37: 10.2x ← 38: 10.6x ↑ 39: 9.8 ← 40: 10.6x ↑</p> <p>Series 102.3 411.8</p>
<p>60 Shots</p>	<p>41: 10.7x ↖ 42: 10.4x ↑ 43: 10.7x ↗ 44: 10.0 ↘ 45: 10.7x ← 46: 10.8x ↑ 47: 10.0 ↗ 48: 9.9 ↑ 49: 9.9 → 50: 9.7 ↗</p> <p>Series 102.8 514.6</p>	<p>60 Shots</p>	<p>51: 10.7x ↖ 52: 10.3x ↓ 53: 10.3x ↖ 54: 10.5x ↑ 55: 10.6x ↓ 56: 10.3x → 57: 10.1 ↑ 58: 10.2x ← 59: 10.4x ↗ 60: 10.0 ↘</p> <p>Series 103.4 618.0</p>

<p>60 Shots</p>	<p>1: 10.4x ↑</p> <p>2: 10.1 ↓</p> <p>3: 10.5x ←</p> <p>4: 9.4 ↘</p> <p>5: 10.8x ↙</p> <p>6: 10.4x →</p> <p>7: 9.5 ←</p> <p>8: 10.6x ↗</p> <p>9: 10.6x ↑</p> <p>10: 9.3 ↖</p> <hr/> <p>Series 101.6</p> <p style="text-align: center;">101.6</p>	<p>60 Shots</p>	<p>11: 10.3x ↑</p> <p>12: 10.7x ←</p> <p>13: 10.1 ↙</p> <p>14: 9.5 →</p> <p>15: 10.6x ↘</p> <p>16: 9.9 →</p> <p>17: 10.6x ←</p> <p>18: 10.0 ↖</p> <p>19: 10.5x →</p> <p>20: 9.4 →</p> <hr/> <p>Series 101.6</p> <p style="text-align: center;">203.2</p>
<p>60 Shots</p>	<p>21: 10.5x →</p> <p>22: 9.0 ←</p> <p>23: 10.6x ↓</p> <p>24: 9.4 ↘</p> <p>25: 10.0 ↗</p> <p>26: 10.8x ←</p> <p>27: 10.3x ↓</p> <p>28: 10.7x →</p> <p>29: 10.9x ↙</p> <p>30: 9.2 ↑</p> <hr/> <p>Series 101.4</p> <p style="text-align: center;">304.6</p>	<p>60 Shots</p>	<p>31: 10.5x ←</p> <p>32: 10.2x ↓</p> <p>33: 10.2x ↓</p> <p>34: 10.2x ↓</p> <p>35: 10.5x ↙</p> <p>36: 10.0 ↗</p> <p>37: 10.4x ↓</p> <p>38: 9.7 →</p> <p>39: 9.2 ←</p> <p>40: 10.2x ↑</p> <hr/> <p>Series 101.1</p> <p style="text-align: center;">405.7</p>
<p>60 Shots</p>	<p>41: 10.7x ↓</p> <p>42: 10.2x ↙</p> <p>43: 10.1 ↑</p> <p>44: 9.5 ↓</p> <p>45: 10.3x ↗</p> <p>46: 10.8x ↙</p> <p>47: 9.9 ↗</p> <p>48: 10.4x ↗</p> <p>49: 10.3x →</p> <p>50: 10.3x ↑</p> <hr/> <p>Series 102.5</p> <p style="text-align: center;">508.2</p>	<p>60 Shots</p>	<p>51: 10.0 ↖</p> <p>52: 9.9 ↖</p> <p>53: 9.8 →</p> <p>54: 9.4 ↑</p> <p>55: 10.2x →</p> <p>56: 9.8 ↓</p> <p>57: 10.0 ↗</p> <p>58: 10.4x ↗</p> <p>59: 10.7x ↓</p> <p>60: 10.6x ↗</p> <hr/> <p>Series 100.8</p> <p style="text-align: center;">609.0</p>

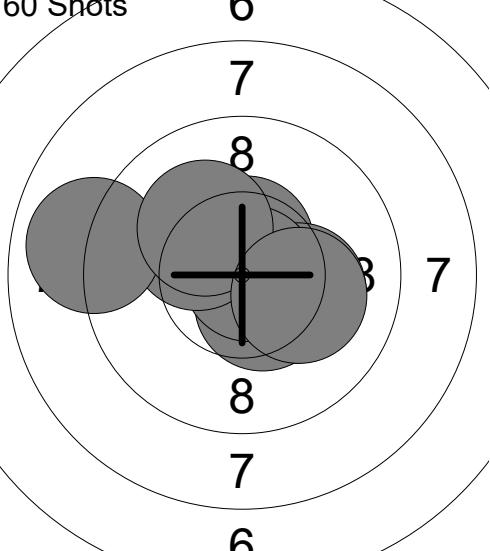
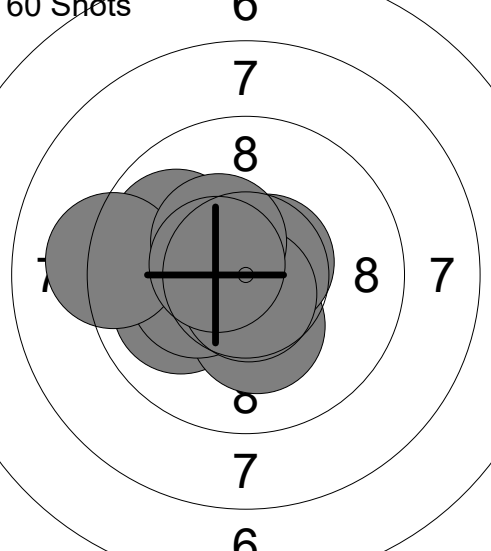
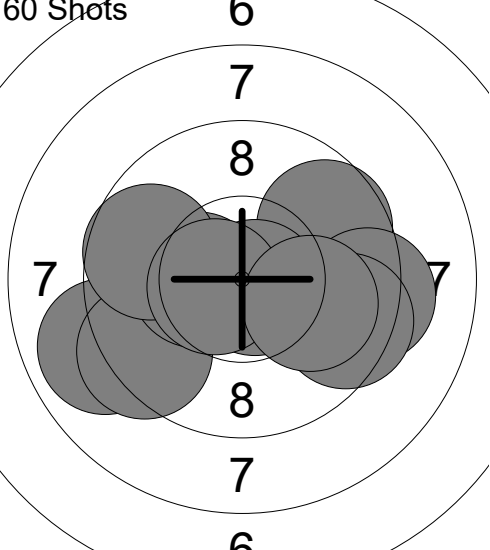
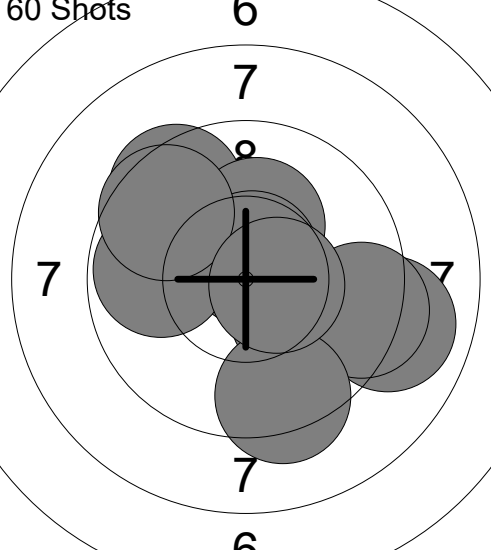
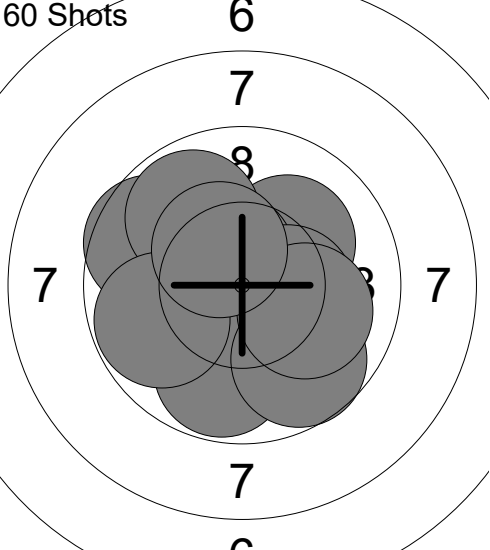
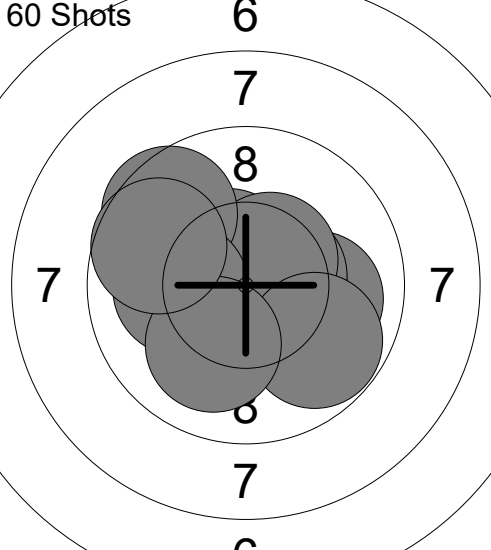
60 Shots 	1: 10.5x ↑ 2: 10.5x ↓ 3: 10.2x → 4: 10.2x → 5: 10.5x ↓ 6: 10.9x → 7: 10.2x ↗ 8: 8.9 ← 9: 10.2x ↗ 10: 10.2x → Series 102.3 102.3	60 Shots 	11: 10.7x ↓ 12: 10.0 ← 13: 9.9 ↖ 14: 10.3x ↓ 15: 10.6x ↗ 16: 10.3x ← 17: 10.7x ↓ 18: 9.2 ← 19: 10.4x ↗ 20: 10.5x ← Series 102.6 204.9
60 Shots 	21: 9.7 ↗ 22: 9.3 → 23: 8.9 ← 24: 9.3 ← 25: 10.8x ↓ 26: 10.4x ← 27: 9.7 ↖ 28: 10.6x ← 29: 9.5 → 30: 10.0 → Series 98.2 303.1	60 Shots 	31: 9.0 → 32: 9.5 ↗ 33: 10.2x ↑ 34: 10.1 → 35: 9.4 → 36: 9.3 ↓ 37: 10.7x ↑ 38: 9.8 ← 39: 9.6 ↗ 40: 10.5x → Series 98.1 401.2
60 Shots 	41: 10.1 ↗ 42: 10.6x ↗ 43: 10.3x → 44: 9.8 ↓ 45: 9.6 ↖ 46: 9.7 ↓ 47: 9.8 ↗ 48: 9.8 ← 49: 10.0 → 50: 10.4x ↗ Series 100.1 501.3	60 Shots 	51: 10.0 → 52: 10.5x → 53: 10.5x → 54: 10.5x ↗ 55: 10.5x ↗ 56: 9.6 ↗ 57: 9.8 → 58: 10.1 ← 59: 10.1 ↓ 60: 9.7 ↖ Series 101.3 602.6

<p>60 Shots</p>	<p>1: 9.6 ← 2: 10.2x ↗ 3: 9.8 ↖ 4: 10.0 ↓ 5: 9.1 → 6: 10.3x ↘ 7: 9.7 ↖ 8: 7.6 → 9: 10.6x ↓ 10: 9.6 ↘</p> <p>Series 96.5 96.5</p>	<p>60 Shots</p>	<p>11: 10.5x ↑ 12: 9.9 ↓ 13: 10.1 → 14: 9.4 ↘ 15: 10.2x ← 16: 9.1 ↘ 17: 9.1 ↓ 18: 9.6 → 19: 10.4x ↘ 20: 10.4x ↖</p> <p>Series 98.7 195.2</p>
<p>60 Shots</p>	<p>21: 10.0 → 22: 10.8x ← 23: 10.2x ← 24: 10.6x ↘ 25: 10.4x ↘ 26: 10.5x ↗ 27: 10.4x ↓ 28: 10.7x ← 29: 9.5 ↑ 30: 9.8 →</p> <p>Series 102.9 298.1</p>	<p>60 Shots</p>	<p>31: 9.9 ↑ 32: 10.2x ↖ 33: 10.8x ↑ 34: 10.1 ↓ 35: 9.4 ↘ 36: 10.6x ↗ 37: 10.2x ↓ 38: 10.0 ← 39: 8.8 ← 40: 10.7x ↘</p> <p>Series 100.7 398.8</p>
<p>60 Shots</p>	<p>41: 9.9 ↑ 42: 10.2x ← 43: 9.2 → 44: 9.8 ↑ 45: 10.2x ↗ 46: 9.1 ← 47: 10.2x ↗ 48: 10.3x ← 49: 10.9x → 50: 10.3x ↓</p> <p>Series 100.1 498.9</p>	<p>60 Shots</p>	<p>51: 9.9 ← 52: 9.9 ↑ 53: 9.3 ↘ 54: 10.3x ← 55: 10.7x → 56: 10.0 ↘ 57: 9.8 → 58: 9.6 ↓ 59: 9.0 → 60: 9.8 →</p> <p>Series 98.3 597.2</p>

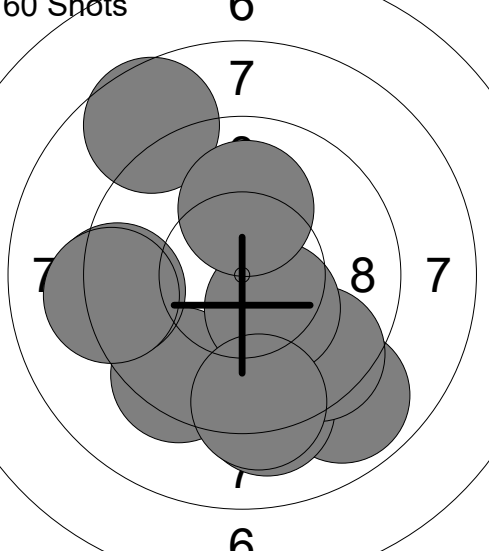
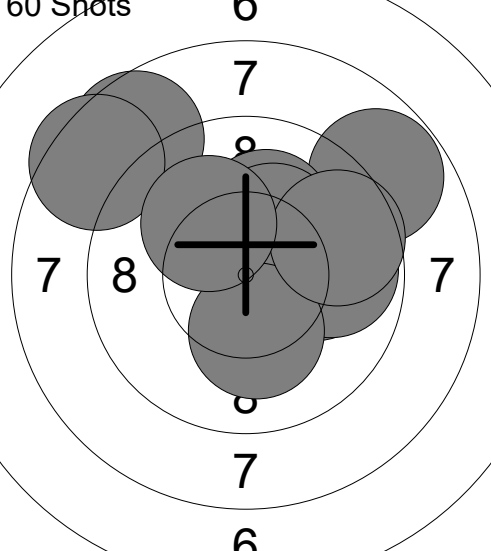
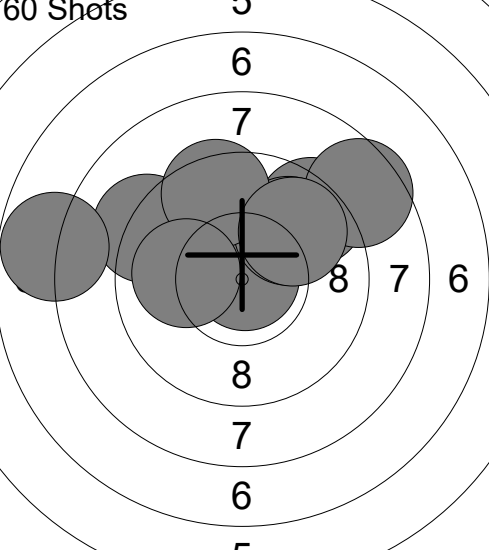
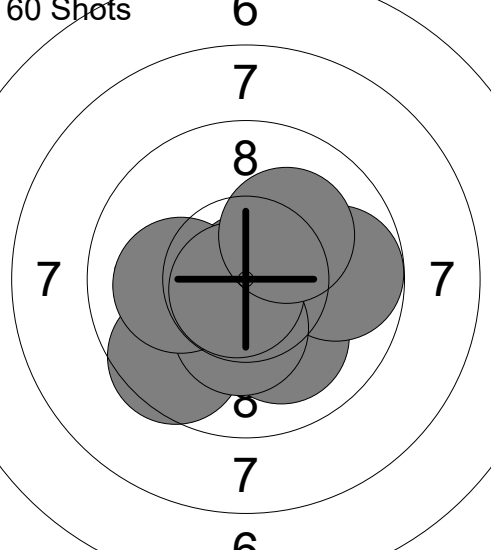
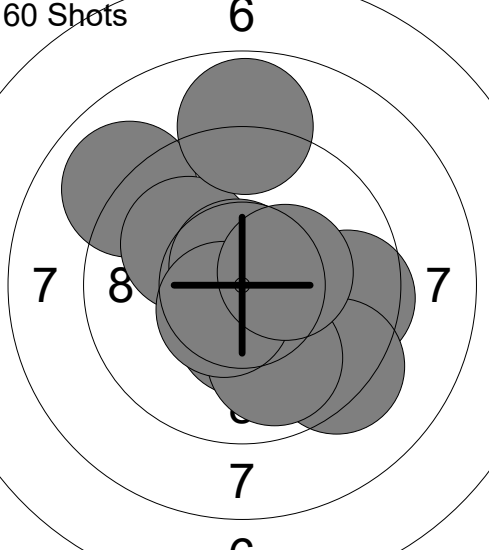
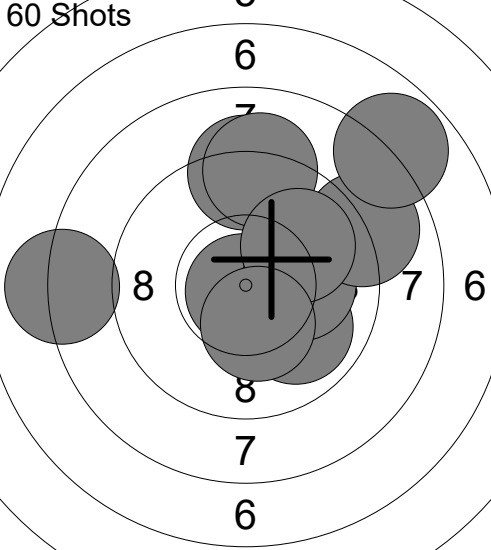
<p>60 Shots 6</p> 	<p>1: 8.9 ↘ 2: 9.4 ↘ 3: 9.3 ← 4: 9.2 ← 5: 9.2 ↘ 6: 9.5 ↘ 7: 10.4x ↘ 8: 8.6 ↗ 9: 10.1 ↑ 10: 9.3 ↘</p> <p>Series 93.9</p>	<p>60 Shots 6</p> 	<p>11: 10.0 → 12: 8.8 ↗ 13: 8.6 ↗ 14: 8.5 ↗ 15: 10.1 ↑ 16: 10.3x ↗ 17: 9.8 → 18: 10.2x ↘ 19: 9.6 → 20: 10.1 ↗</p> <p>Series 96.0</p>
	93.9		189.9
<p>60 Shots 5</p> 	<p>21: 10.2x ↗ 22: 9.2 ↖ 23: 10.9x ↗ 24: 9.4 ↗ 25: 8.5 ↗ 26: 9.8 ↗ 27: 9.5 ↑ 28: 10.0 ← 29: 7.8 ← 30: 9.8 ↗</p> <p>Series 95.1</p>	<p>60 Shots 6</p> 	<p>31: 10.0 ↘ 32: 10.2x → 33: 9.6 ↘ 34: 10.9x → 35: 10.1 ↘ 36: 9.8 → 37: 10.3x ↘ 38: 10.1 ← 39: 10.8x ↘ 40: 10.2x ↗</p> <p>Series 102.0</p>
	285.0		387.0
<p>60 Shots 6</p> 	<p>41: 10.4x ↘ 42: 9.0 ↗ 43: 10.1 ↗ 44: 8.8 ↑ 45: 10.7x ↑ 46: 9.5 → 47: 9.3 ↘ 48: 9.9 ↘ 49: 10.6x ↘ 50: 10.4x →</p> <p>Series 98.7</p>	<p>60 Shots 6</p> 	<p>51: 9.2 ↑ 52: 9.9 ↘ 53: 9.1 ↑ 54: 10.8x ↘ 55: 10.1 → 56: 8.1 ← 57: 8.9 → 58: 7.8 ↗ 59: 9.9 ↗ 60: 10.3x ↘</p> <p>Series 94.1</p>
	485.7		579.8