

<p>60 Shots</p> 	<p>1: 9.9 ↓ 2: 10.1 → 3: 9.5 → 4: 10.1 → 5: 10.6x ← 6: 9.8 ↗ 7: 10.7x ↖ 8: 10.6x → 9: 10.7x → 10: 9.8 →</p> <p>Series 101.8 101.8</p>	<p>60 Shots</p> 	<p>11: 10.5x ↓ 12: 10.5x ↘ 13: 10.2x ↓ 14: 10.2x → 15: 10.5x ← 16: 10.6x ← 17: 10.6x ↑ 18: 9.8 ← 19: 10.4x ↓ 20: 10.3x ↖</p> <p>Series 103.6 205.4</p>
<p>60 Shots</p> 	<p>21: 10.3x ↓ 22: 10.6x ↑ 23: 10.6x ↘ 24: 10.6x ↙ 25: 10.5x ↑ 26: 10.5x ← 27: 10.6x ↘ 28: 10.4x ↑ 29: 10.3x ↓ 30: 10.2x ↑</p> <p>Series 104.6 310.0</p>	<p>60 Shots</p> 	<p>31: 10.4x ↓ 32: 10.7x ↘ 33: 10.7x ↓ 34: 9.9 ↙ 35: 10.8x ↗ 36: 9.3 ↗ 37: 9.6 ↖ 38: 10.0 → 39: 9.9 ← 40: 10.7x ↓</p> <p>Series 102.0 412.0</p>
<p>60 Shots</p> 	<p>41: 10.4x ← 42: 10.0 ↗ 43: 10.8x ↗ 44: 10.7x → 45: 9.1 ↑ 46: 10.7x ↓ 47: 9.9 ↗ 48: 10.2x → 49: 10.0 ↗ 50: 10.5x ↘</p> <p>Series 102.3 514.3</p>	<p>60 Shots</p> 	<p>51: 10.7x ↑ 52: 10.6x ↖ 53: 10.0 ↑ 54: 10.3x ↘ 55: 10.4x ↙ 56: 9.3 ↗ 57: 10.2x ↓ 58: 10.5x ← 59: 10.7x ↙ 60: 10.0 ←</p> <p>Series 102.7 617.0</p>

<p>60 Shots</p>  <p style="text-align: center;">6 7 8 7 7</p> <p style="text-align: right;">Series 97.5 97.5</p>	<p>1: 10.0 ↙ 2: 8.8 → 3: 10.3x → 4: 10.1 ↙ 5: 10.2x ← 6: 10.1 ↘ 7: 9.3 ↗ 8: 9.1 ↗ 9: 10.2x ↓ 10: 9.4 ↗</p> <p style="text-align: right;">Series 97.5 97.5</p>	<p>60 Shots</p>  <p style="text-align: center;">6 7 8 7 6</p> <p style="text-align: right;">Series 94.8 192.3</p>	<p>11: 9.8 → 12: 10.4x ↗ 13: 9.3 → 14: 9.8 → 15: 8.7 ↑ 16: 10.2x ← 17: 8.8 ↗ 18: 8.3 → 19: 9.6 ↖ 20: 9.9 ↑</p>
<p>60 Shots</p>  <p style="text-align: center;">6 7 8 7 7</p> <p style="text-align: right;">Series 97.5 289.8</p>	<p>21: 8.8 → 22: 10.1 ↗ 23: 9.4 → 24: 9.8 → 25: 9.8 → 26: 10.1 ↗ 27: 10.0 ↖ 28: 9.3 → 29: 9.7 → 30: 10.5x ↙</p> <p style="text-align: right;">Series 97.5 289.8</p>	<p>60 Shots</p>  <p style="text-align: center;">6 7 8 7 6</p> <p style="text-align: right;">Series 95.9 385.7</p>	<p>31: 8.9 → 32: 10.4x → 33: 9.3 ← 34: 9.9 ↑ 35: 10.3x → 36: 10.5x ↓ 37: 9.8 → 38: 9.3 → 39: 8.7 → 40: 8.8 →</p>
<p>60 Shots</p>  <p style="text-align: center;">6 7 7 7 6</p> <p style="text-align: right;">Series 94.4 480.1</p>	<p>41: 10.6x ↗ 42: 9.4 ↗ 43: 8.4 → 44: 9.8 ↑ 45: 10.1 ↓ 46: 8.9 ↖ 47: 9.3 → 48: 8.9 ↘ 49: 9.4 ← 50: 9.6 ↓</p> <p style="text-align: right;">Series 94.4 480.1</p>	<p>60 Shots</p>  <p style="text-align: center;">6 7 8 8 7 6</p> <p style="text-align: right;">Series 97.1 577.2</p>	<p>51: 9.0 ↓ 52: 10.1 → 53: 10.2x ↗ 54: 9.3 ↖ 55: 9.9 → 56: 8.0 → 57: 10.3x → 58: 10.3x ← 59: 10.4x → 60: 9.6 ↙</p>

<p>60 Shots</p> 	<p>1: 10.6x ↓ 2: 9.9 ↙ 3: 10.9x → 4: 9.1 → 5: 8.5 ↗ 6: 10.4x ↓ 7: 9.7 ↗ 8: 10.6x ↓ 9: 9.5 ↓ 10: 9.9 →</p> <p>Series 99.1</p>	<p>60 Shots</p> 	<p>11: 10.0 ↘ 12: 10.1 → 13: 9.9 → 14: 9.2 ← 15: 10.2x ↗ 16: 10.1 → 17: 9.8 ↗ 18: 10.6x → 19: 10.3x ↓ 20: 10.4x ↖</p> <p>Series 100.6</p>
	99.1		199.7
<p>60 Shots</p> 	<p>21: 9.8 ↑ 22: 10.5x ↓ 23: 10.5x → 24: 9.7 ← 25: 10.2x ← 26: 10.5x ↗ 27: 10.6x ↓ 28: 10.3x → 29: 10.0 → 30: 9.0 ↑</p> <p>Series 101.1</p>	<p>60 Shots</p> 	<p>31: 9.9 ← 32: 9.9 → 33: 9.5 ↗ 34: 10.1 ↖ 35: 10.0 ↑ 36: 10.5x ← 37: 10.1 ↘ 38: 10.6x ↓ 39: 10.8x ← 40: 10.4x ↓</p> <p>Series 101.8</p>
	300.8		402.6
<p>60 Shots</p> 	<p>41: 10.3x ↓ 42: 10.5x ← 43: 10.8x ↗ 44: 9.9 ← 45: 10.1 ↑ 46: 9.8 ↓ 47: 10.3x ↓ 48: 10.4x ↗ 49: 10.1 ↗ 50: 10.2x ↓</p> <p>Series 102.4</p>	<p>60 Shots</p> 	<p>51: 9.5 → 52: 10.4x ← 53: 9.6 → 54: 9.9 ← 55: 10.0 ↖ 56: 10.6x → 57: 10.3x → 58: 10.6x ↓ 59: 10.5x ← 60: 10.3x ↓</p> <p>Series 101.7</p>
	505.0		606.7

Comment	Signature		
---------	-----------	--	--

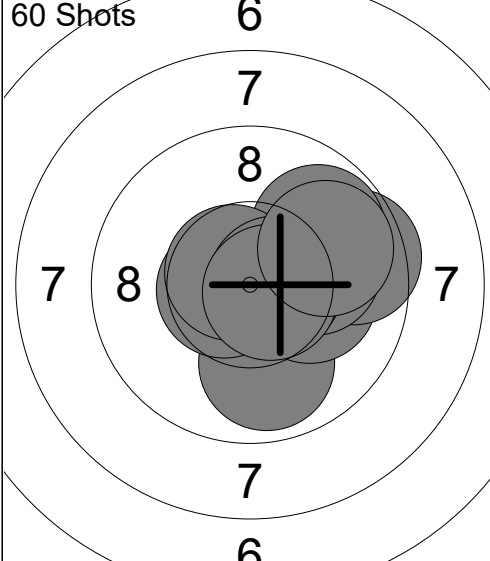
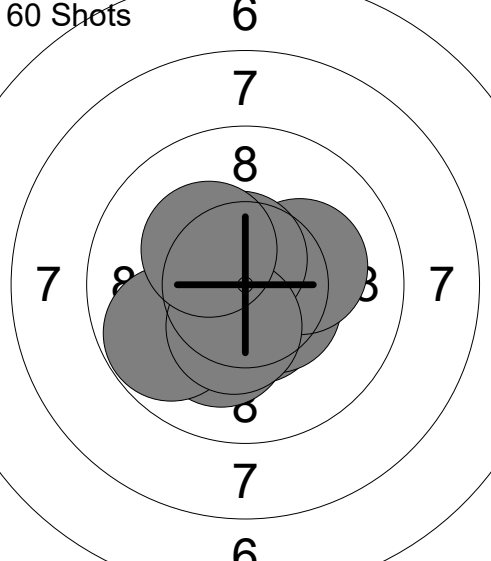
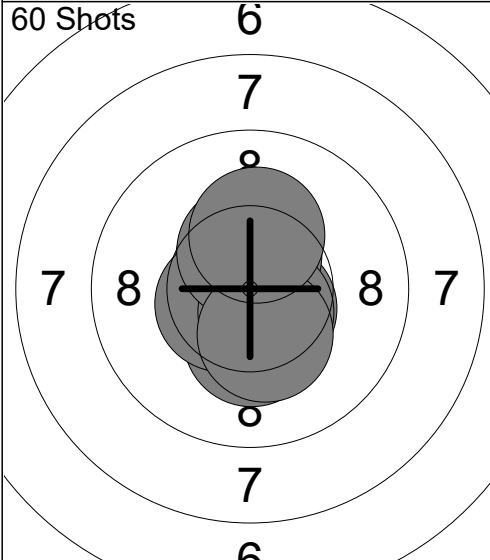
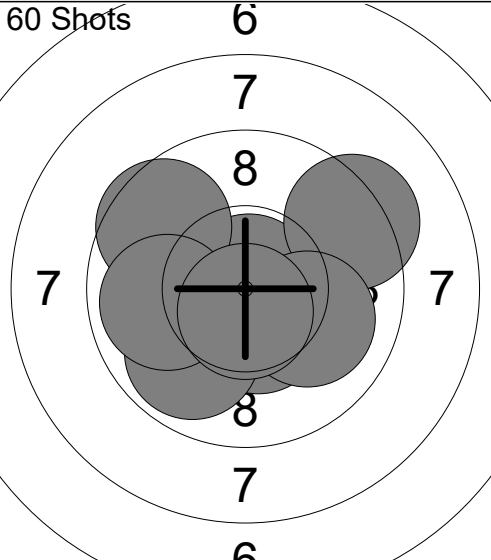
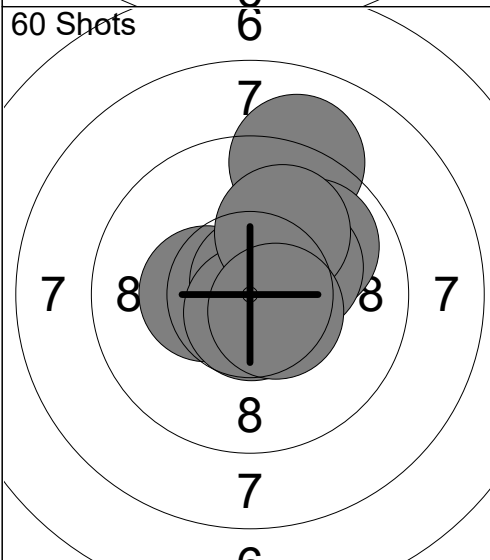
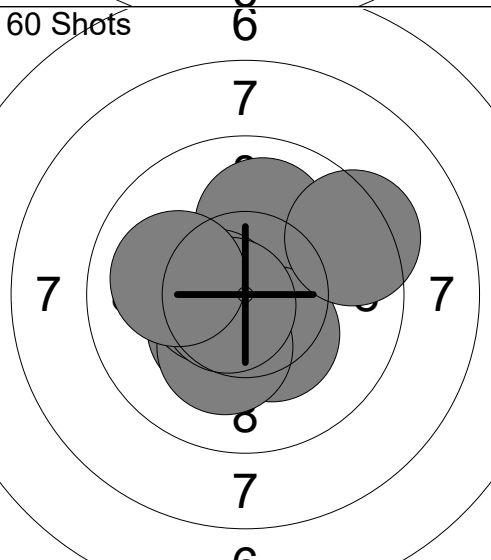
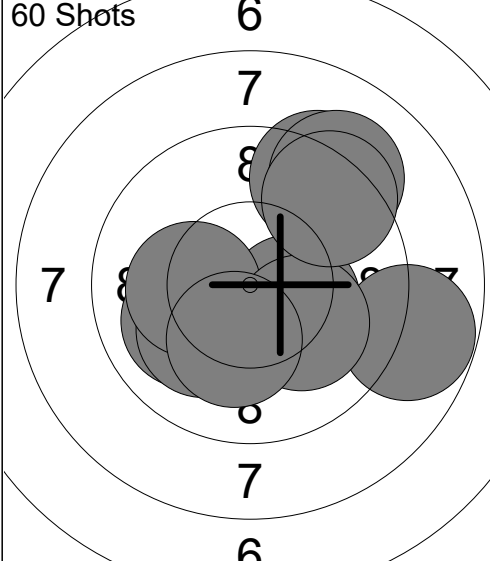
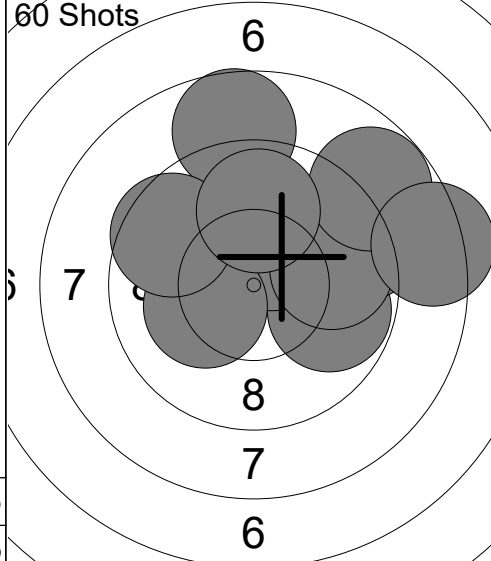
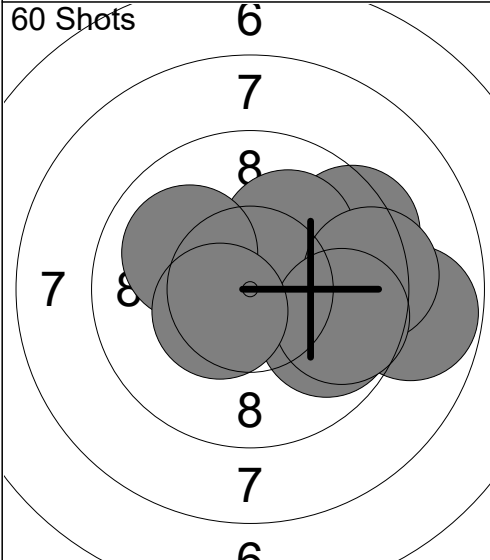
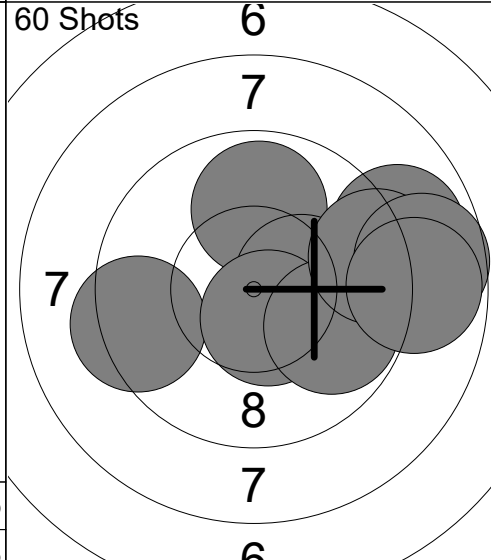
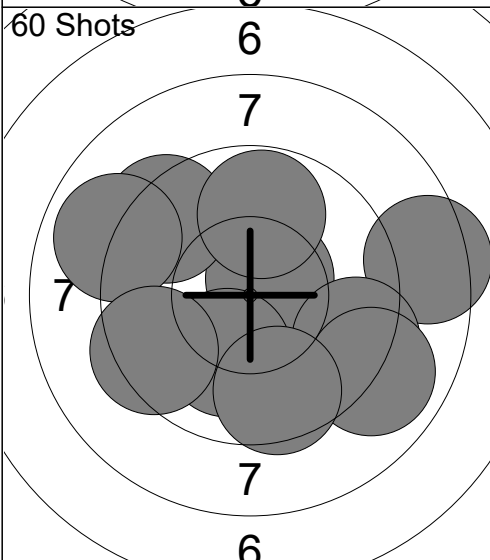
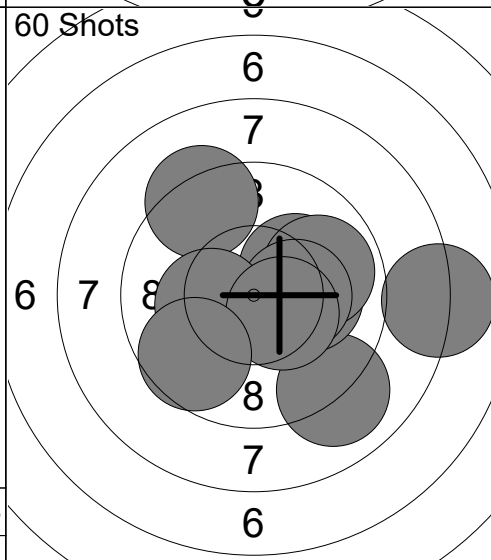
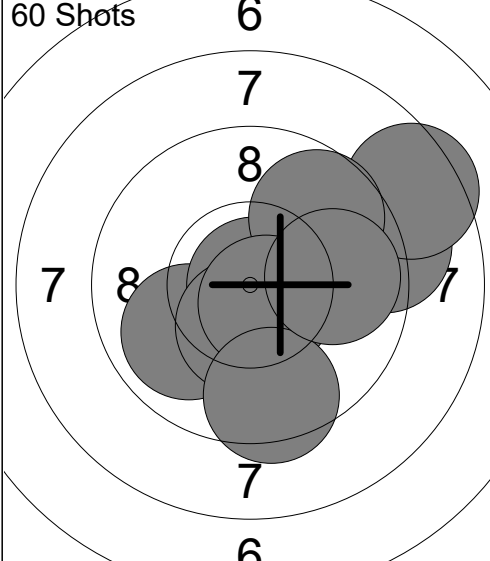
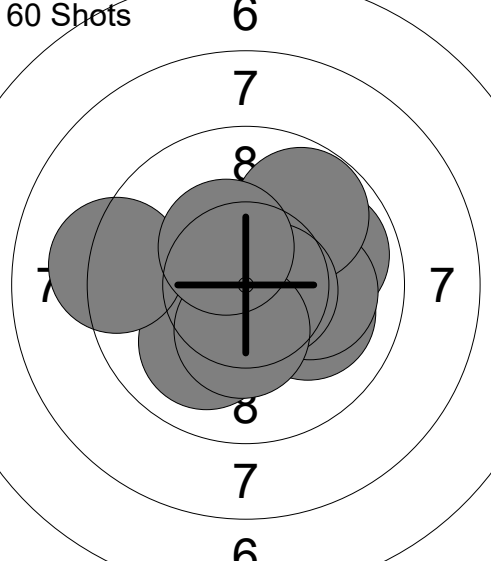
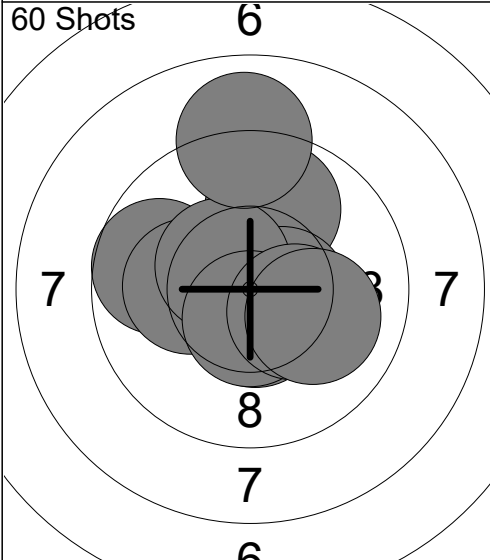
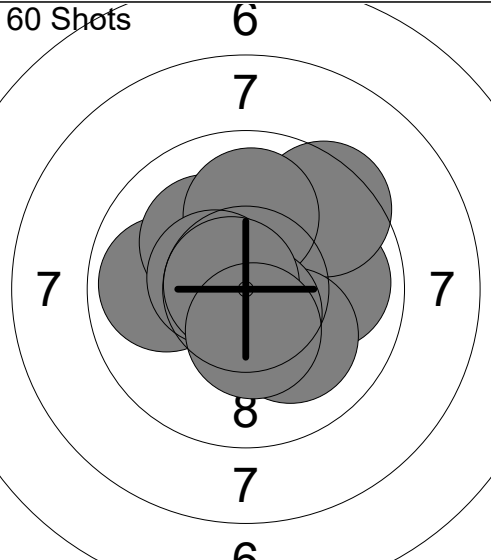
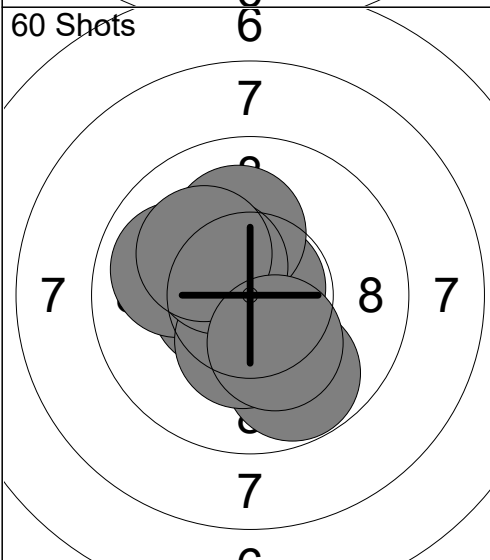
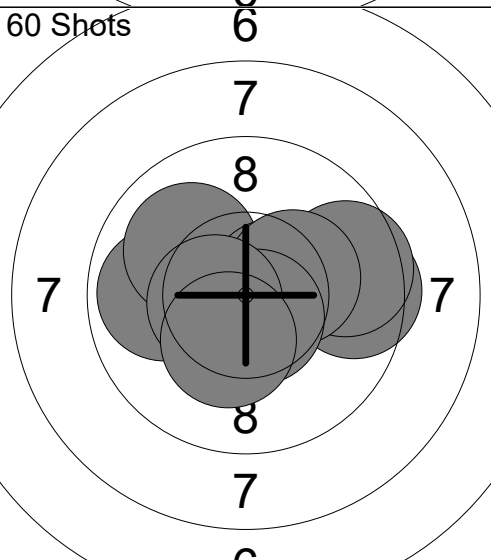
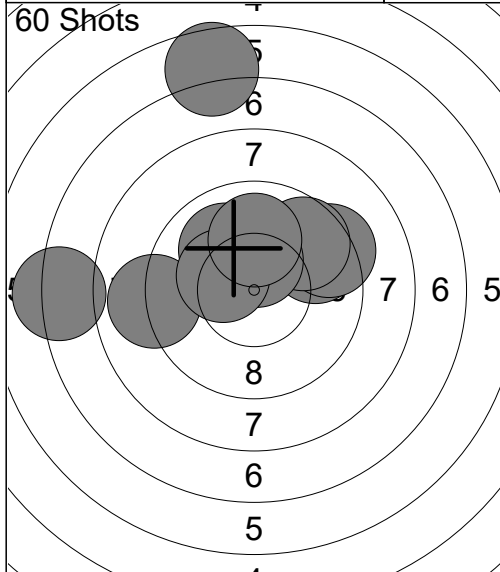

1:	9.6	→
2:	6.6	↑
3:	9.3	→
4:	9.6	→
5:	10.4x	↑
6:	9.0	←
7:	10.0	↑
8:	7.2	←
9:	10.3x	←
10:	10.0	↑
Series		92.0
		92.0

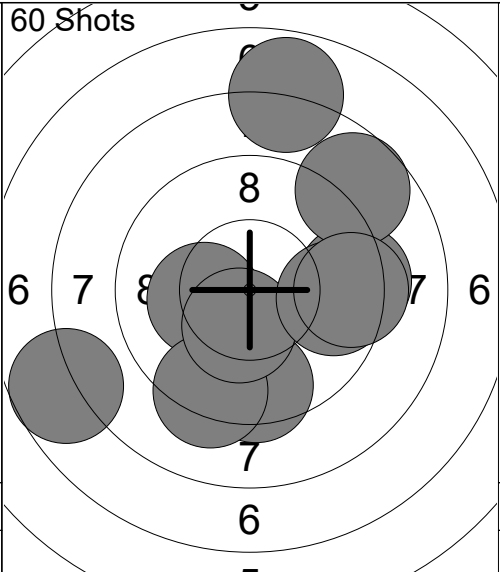

11:	9.5	↓
12:	10.2x	←
13:	9.3	→
14:	7.7	←
15:	7.9	↑
16:	9.3	↓
17:	8.7	→
18:	10.4x	↓
19:	9.6	→
20:	9.4	→
Series		92.0
		184.0

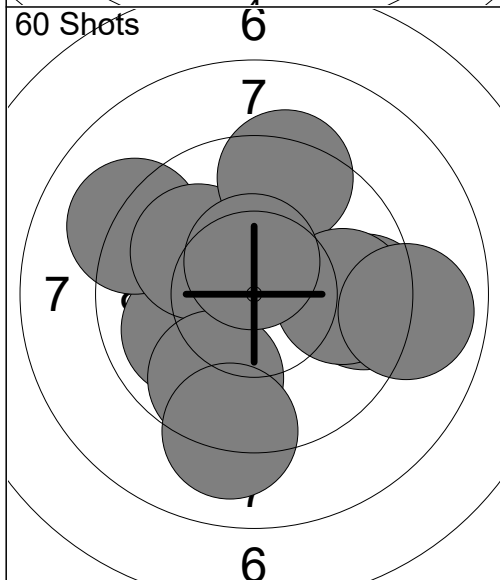

21:	10.0	←
22:	9.1	←
23:	10.0	←
24:	9.7	↓
25:	9.1	↓
26:	9.5	→
27:	9.4	↑
28:	9.8	→
29:	10.5x	↑
30:	8.9	→
Series		96.0
		280.0

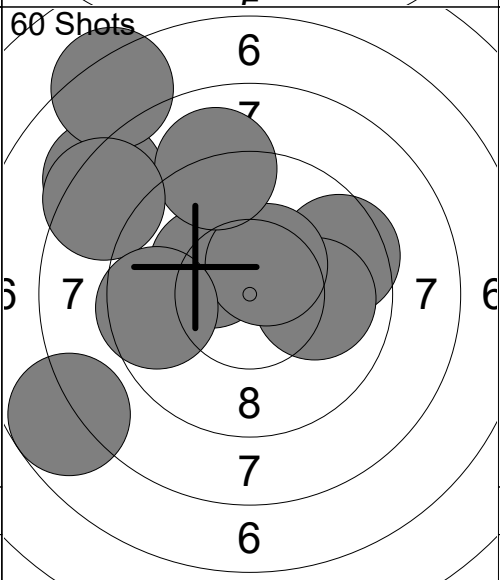

31:	9.5	→
32:	8.2	←
33:	10.0	→
34:	10.2x	←
35:	10.5x	↑
36:	7.8	←
37:	9.0	↑
38:	7.3	↑
39:	8.4	←
40:	9.6	←
Series		90.5
		370.5

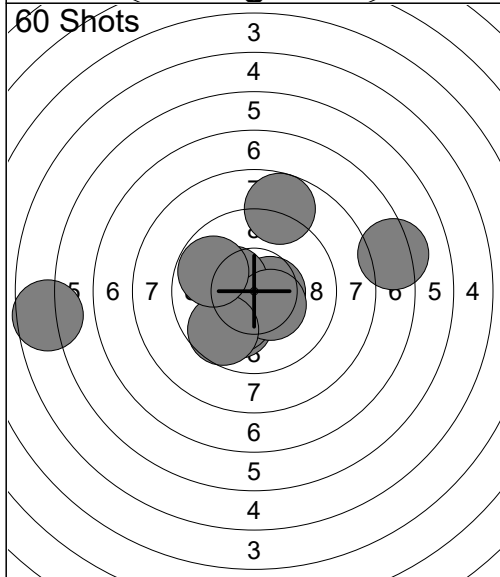

41:	5.7	←
42:	7.3	→
43:	10.6x	→
44:	10.3x	←
45:	10.0	↓
46:	10.2x	↓
47:	10.4x	↓
48:	9.7	↓
49:	9.8	←
50:	8.8	↑
Series		92.8
		463.3

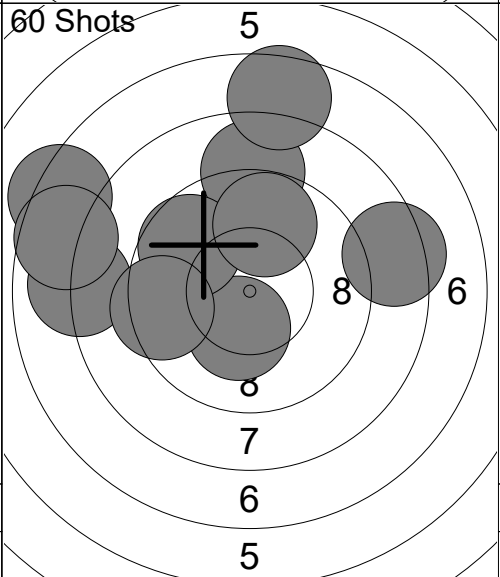

51:	8.0	←
52:	10.3x	↓
53:	8.9	↑
54:	9.7	←
55:	9.8	↑
56:	7.3	←
57:	7.6	←
58:	9.4	←
59:	7.6	↑
60:	8.4	→
Series		87.0
		550.3

Relay 3	Lane 6	EVERETTE Preston
-------------------	------------------	-------------------------

1-80	Patriots Shooting Club	Precision	
------	------------------------	-----------	--

31.01.2025	2025 AirNats by X Count	Civilian Marksmanship Program	
------------	-------------------------	-------------------------------	--

Comment	Signature		
---------	-----------	--	--

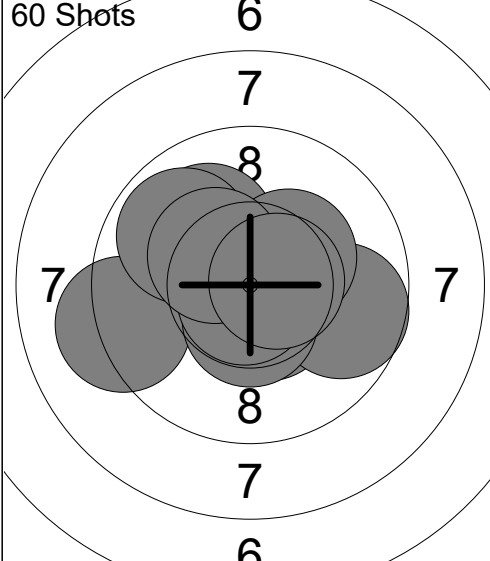
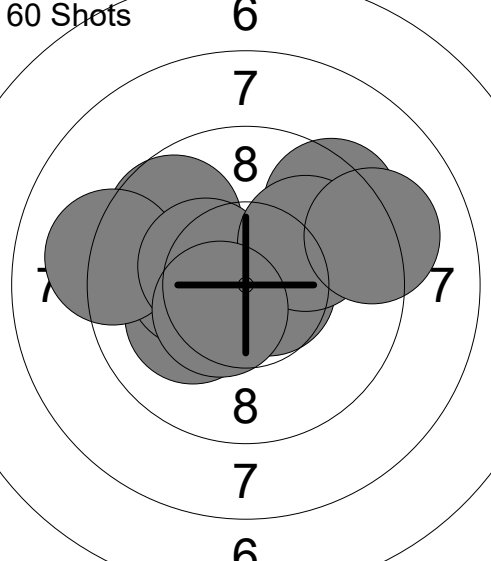
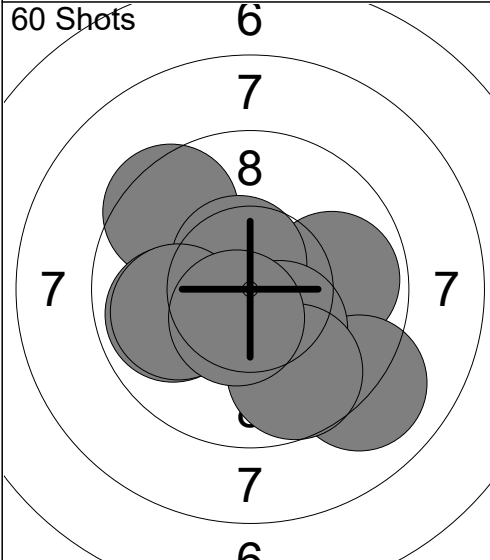
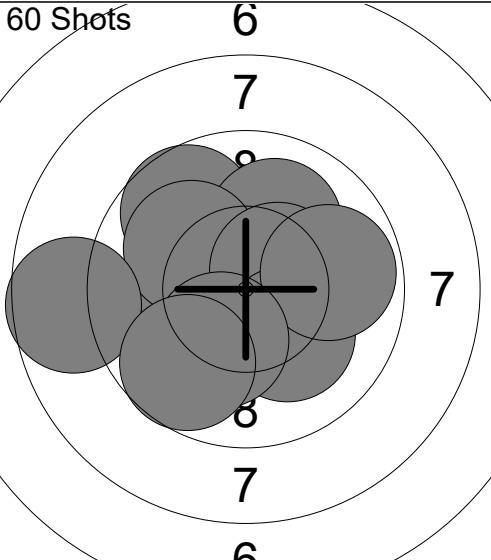
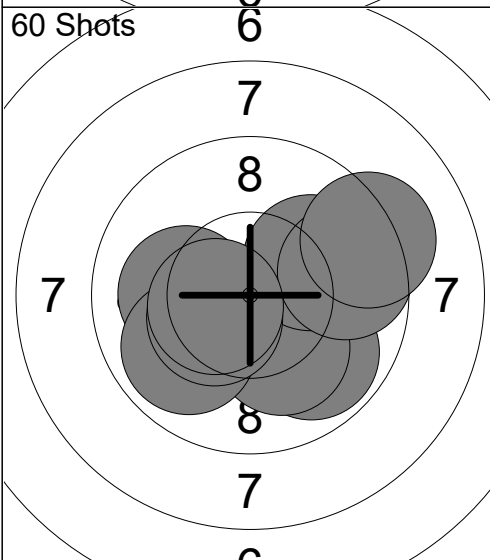
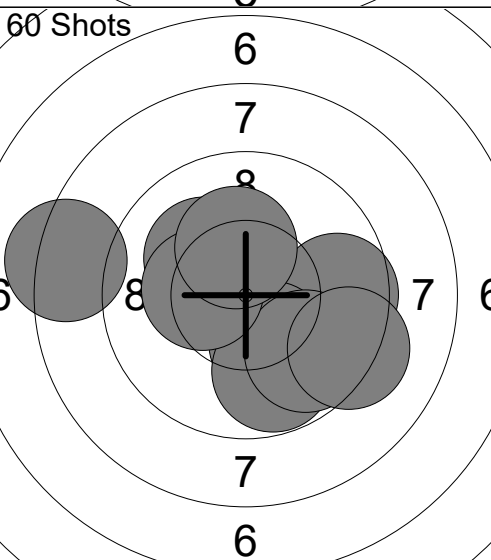
<p>60 Shots</p> 	<p>1: 9.2 ←</p> <p>2: 10.1 ↗</p> <p>3: 10.5x ↓</p> <p>4: 9.7 →</p> <p>5: 10.5x ↓</p> <p>6: 10.8x ↓</p> <p>7: 9.9 ↗</p> <p>8: 10.3x ↗</p> <p>9: 10.3x ↗</p> <p>10: 10.6x →</p> <hr/> <p>Series 101.9</p> <p style="text-align: center;">101.9</p>	<p>60 Shots</p> 	<p>11: 10.7x →</p> <p>12: 9.7 ↖</p> <p>13: 10.1 ←</p> <p>14: 10.3x ←</p> <p>15: 9.4 ↗</p> <p>16: 9.1 ←</p> <p>17: 10.4x ←</p> <p>18: 10.0 ↗</p> <p>19: 10.5x ↖</p> <p>20: 9.2 →</p> <hr/> <p>Series 99.4</p> <p style="text-align: center;">201.3</p>
<p>60 Shots</p> 	<p>21: 10.7x →</p> <p>22: 9.9 →</p> <p>23: 9.5 ↗</p> <p>24: 10.6x ↗</p> <p>25: 9.9 ←</p> <p>26: 9.0 ↓</p> <p>27: 10.0 ←</p> <p>28: 10.3x ↓</p> <p>29: 9.7 ↓</p> <p>30: 10.5x ↓</p> <hr/> <p>Series 100.1</p> <p style="text-align: center;">301.4</p>	<p>60 Shots</p> 	<p>31: 9.7 ↖</p> <p>32: 10.3x ←</p> <p>33: 10.0 ↗</p> <p>34: 10.1 ↖</p> <p>35: 10.5x ↗</p> <p>36: 10.1 ↓</p> <p>37: 9.8 →</p> <p>38: 8.7 ←</p> <p>39: 10.2x ↓</p> <p>40: 9.7 ↖</p> <hr/> <p>Series 99.1</p> <p style="text-align: center;">400.5</p>
<p>60 Shots</p> 	<p>41: 10.1 ↗</p> <p>42: 9.8 ↓</p> <p>43: 10.1 ↓</p> <p>44: 10.0 ↗</p> <p>45: 10.1 ←</p> <p>46: 9.7 →</p> <p>47: 9.9 ↖</p> <p>48: 10.4x ↖</p> <p>49: 10.5x ↖</p> <p>50: 9.2 →</p> <hr/> <p>Series 99.8</p> <p style="text-align: center;">500.3</p>	<p>60 Shots</p> 	<p>51: 10.2x ↓</p> <p>52: 9.6 →</p> <p>53: 10.2x ↓</p> <p>54: 9.8 ↓</p> <p>55: 9.8 ↓</p> <p>56: 10.1 ↗</p> <p>57: 10.3x ←</p> <p>58: 9.3 →</p> <p>59: 10.2x ↗</p> <p>60: 8.3 ←</p> <hr/> <p>Series 97.8</p> <p style="text-align: center;">598.1</p>

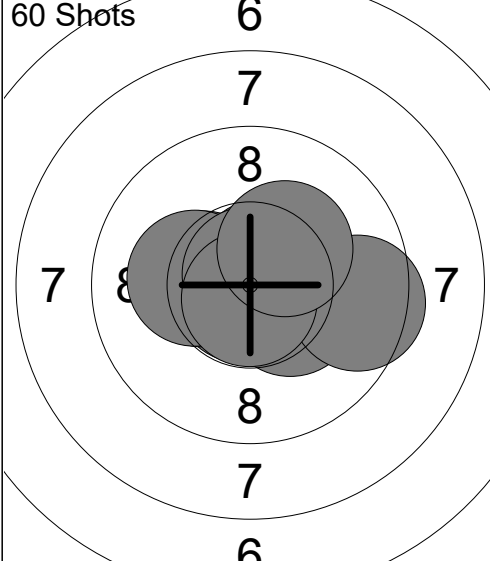
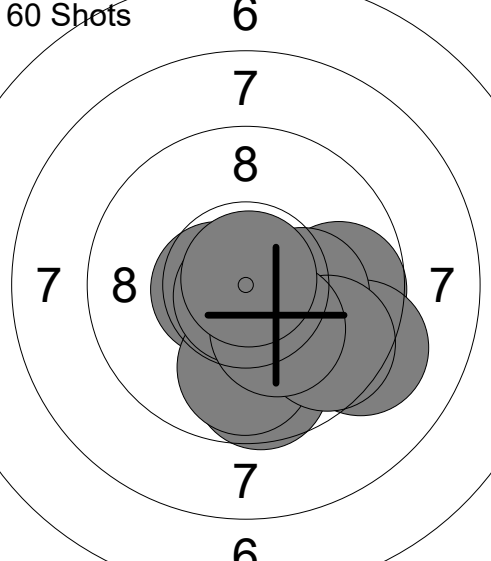
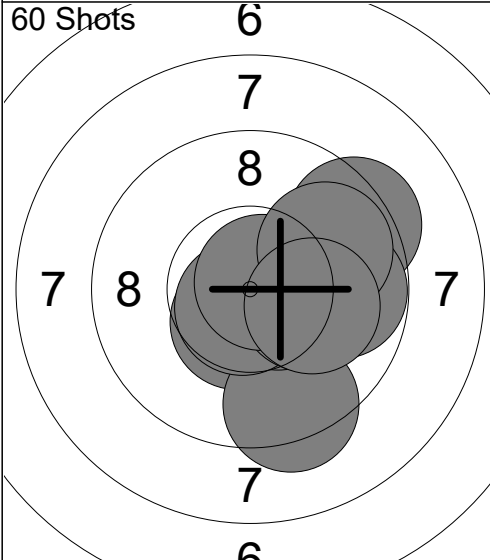
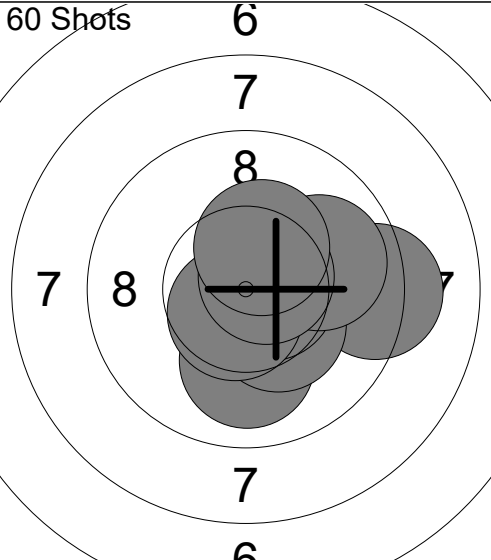
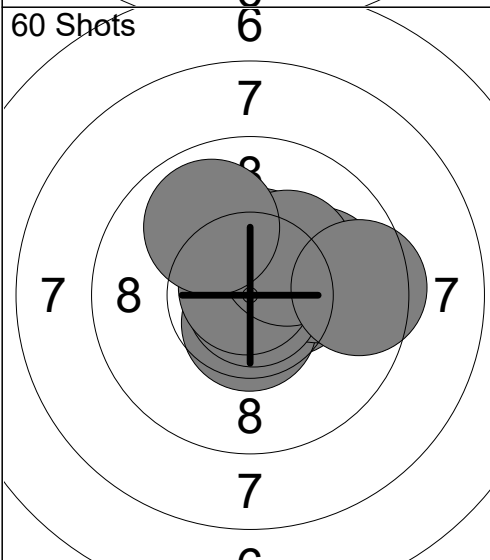
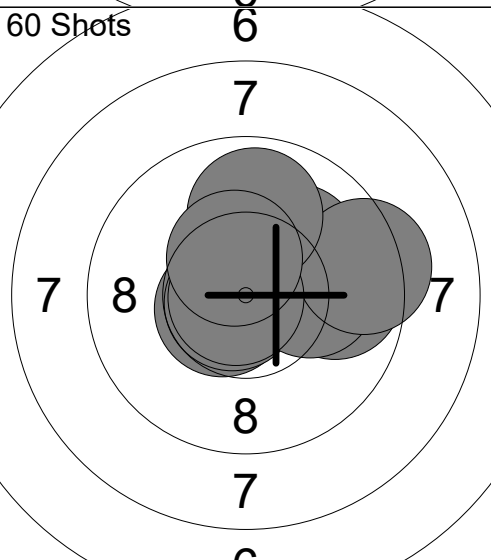
<p>60 Shots</p>  <p style="text-align: center;">6 7 8 7 8 7</p>	<p>1: 10.7x ↘ 2: 10.8x ↙ 3: 10.7x ↗ 4: 10.3x ← 5: 10.2x ← 6: 10.8x ↑ 7: 10.3x ⇒ 8: 9.5 ⇒ 9: 10.8x ↓ 10: 10.3x ↗</p> <p>Series 104.4 104.4</p>	<p>60 Shots</p>  <p style="text-align: center;">6 7 8 7 8 7</p>	<p>11: 10.6x ← 12: 9.7 ⇒ 13: 9.7 ↓ 14: 9.2 ⇒ 15: 9.9 ↓ 16: 10.2x ⇒ 17: 9.6 ⇒ 18: 10.8x ↓ 19: 10.2x ↓ 20: 10.9x ↗</p> <p>Series 100.8 205.2</p>
<p>60 Shots</p>  <p style="text-align: center;">6 7 8 7 8 7</p>	<p>21: 10.5x ↓ 22: 9.3 ↓ 23: 9.3 ↗ 24: 9.8 ⇒ 25: 10.5x ⇒ 26: 10.7x ↓ 27: 10.2x ⇒ 28: 10.8x ↗ 29: 9.8 ↗ 30: 10.1 ⇒</p> <p>Series 101.0 306.2</p>	<p>60 Shots</p>  <p style="text-align: center;">6 7 8 7 8 7</p>	<p>31: 10.0 ↓ 32: 10.3x ⇒ 33: 9.2 ⇒ 34: 10.2x ⇒ 35: 10.3x ↓ 36: 10.6x ⇒ 37: 9.9 ⇒ 38: 10.6x ↓ 39: 10.6x ↗ 40: 10.4x ↗</p> <p>Series 102.1 408.3</p>
<p>60 Shots</p>  <p style="text-align: center;">6 7 8 7 8 7 6</p>	<p>41: 10.5x ⇒ 42: 10.6x ↓ 43: 10.4x ↑ 44: 10.0 ⇒ 45: 10.4x ↗ 46: 10.9x ⇒ 47: 10.8x ↑ 48: 10.3x ↗ 49: 9.9 ↗ 50: 9.5 ⇒</p> <p>Series 103.3 511.6</p>	<p>60 Shots</p>  <p style="text-align: center;">6 7 8 7 8 7 6</p>	<p>51: 10.6x ← 52: 10.1 ↗ 53: 10.7x ← 54: 9.9 ⇒ 55: 9.8 ⇒ 56: 10.1 ⇒ 57: 9.3 ⇒ 58: 10.8x ← 59: 9.9 ↑ 60: 10.4x ↗</p> <p>Series 101.6 613.2</p>

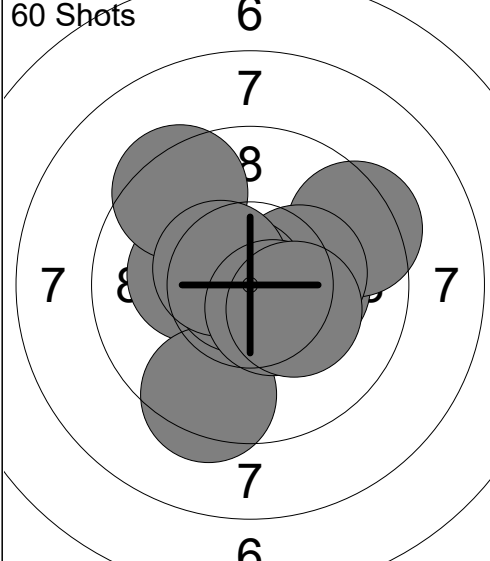
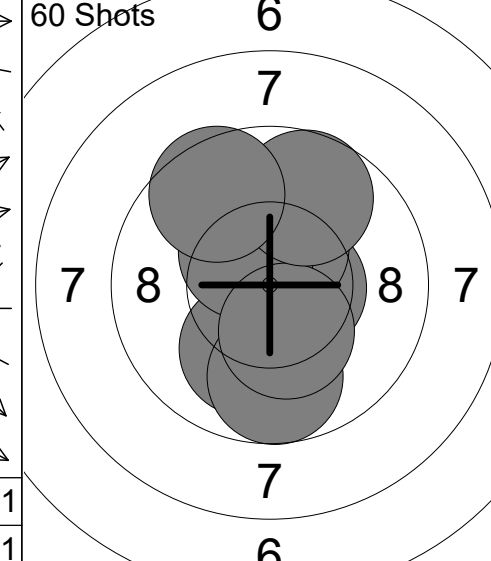
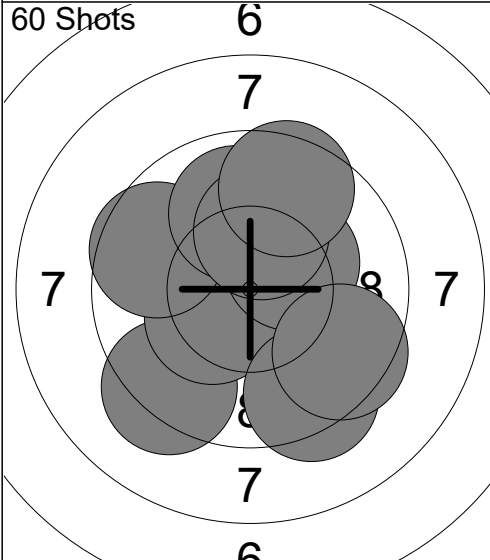
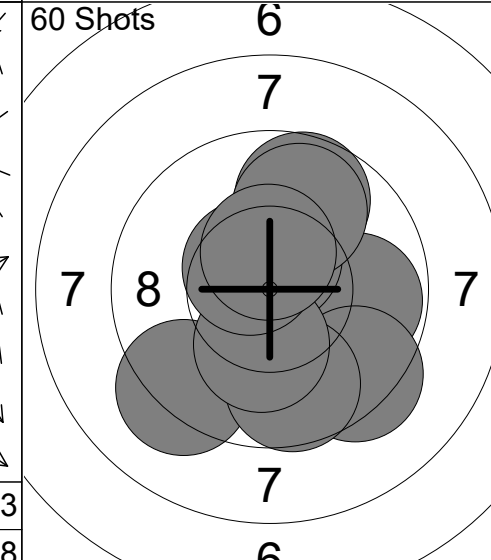
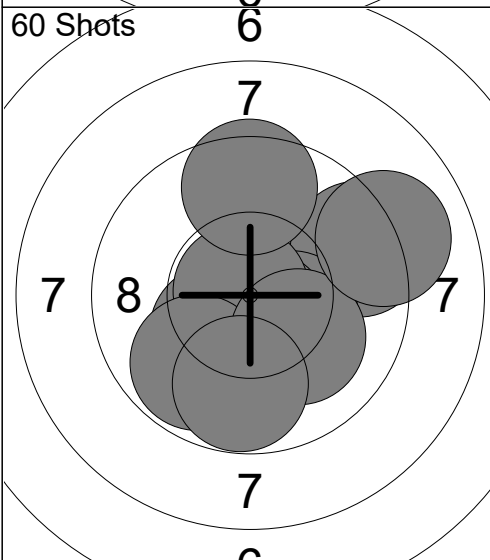
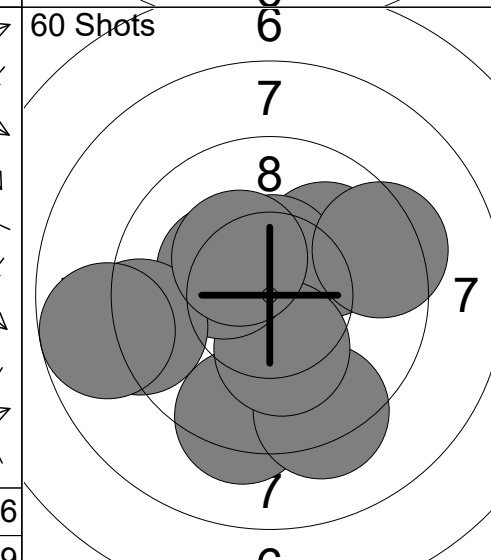
<p>60 Shots</p>  <p style="text-align: center;">6 7 8 7 7 7 7 7 7 7</p>	<p>1: 10.3x →</p> <p>2: 10.2x ←</p> <p>3: 9.4 ↗</p> <p>4: 9.4 ↘</p> <p>5: 10.3x →</p> <p>6: 9.4 ↓</p> <p>7: 10.8x ←</p> <p>8: 10.5x ↖</p> <p>9: 10.5x ↘</p> <p>10: 10.3x →</p> <hr/> <p>Series 101.1</p> <p style="text-align: center;">101.1</p>	<p>60 Shots</p>  <p style="text-align: center;">6 7 8 8 7 7 7 7 7 7</p>	<p>11: 10.1 ↓</p> <p>12: 9.7 ↓</p> <p>13: 9.9 ↑</p> <p>14: 10.7x →</p> <p>15: 10.6x →</p> <p>16: 10.4x ↑</p> <p>17: 10.4x ↖</p> <p>18: 10.3x ↓</p> <p>19: 9.7 ↑</p> <p>20: 9.6 ↖</p> <hr/> <p>Series 101.4</p> <p style="text-align: center;">202.5</p>
<p>60 Shots</p>  <p style="text-align: center;">6 7 8 7 7 7 7 7 7 7</p>	<p>21: 9.3 ↓</p> <p>22: 10.4x ↑</p> <p>23: 10.3x ↙</p> <p>24: 9.6 ↖</p> <p>25: 9.9 ↑</p> <p>26: 10.3x ↘</p> <p>27: 10.2x ↑</p> <p>28: 9.5 ↑</p> <p>29: 9.3 ↓</p> <p>30: 9.5 ↘</p> <hr/> <p>Series 98.3</p> <p style="text-align: center;">300.8</p>	<p>60 Shots</p>  <p style="text-align: center;">6 7 8 7 7 7 7 7 7 7</p>	<p>31: 9.8 →</p> <p>32: 9.7 ↑</p> <p>33: 10.5x ↑</p> <p>34: 9.9 ↑</p> <p>35: 9.4 ↘</p> <p>36: 9.2 ↙</p> <p>37: 9.7 ↓</p> <p>38: 10.2x ↓</p> <p>39: 10.6x ↖</p> <p>40: 10.5x ↑</p> <hr/> <p>Series 99.5</p> <p style="text-align: center;">400.3</p>
<p>60 Shots</p>  <p style="text-align: center;">6 7 8 7 7 7 7 7 7 7</p>	<p>41: 9.4 →</p> <p>42: 10.3x ↙</p> <p>43: 10.3x →</p> <p>44: 10.6x ↓</p> <p>45: 10.8x ↖</p> <p>46: 9.8 ↙</p> <p>47: 10.1 ↓</p> <p>48: 9.8 ↓</p> <p>49: 9.0 →</p> <p>50: 9.5 ↑</p> <hr/> <p>Series 99.6</p> <p style="text-align: center;">499.9</p>	<p>60 Shots</p>  <p style="text-align: center;">6 7 8 7 7 7 7 7 7 7</p>	<p>51: 10.0 ↗</p> <p>52: 9.3 ↓</p> <p>53: 10.5x ↑</p> <p>54: 9.4 →</p> <p>55: 9.3 ↓</p> <p>56: 10.2x ↓</p> <p>57: 10.3x ↖</p> <p>58: 9.2 ←</p> <p>59: 8.7 ←</p> <p>60: 10.3x ↖</p> <hr/> <p>Series 97.2</p> <p style="text-align: center;">597.1</p>

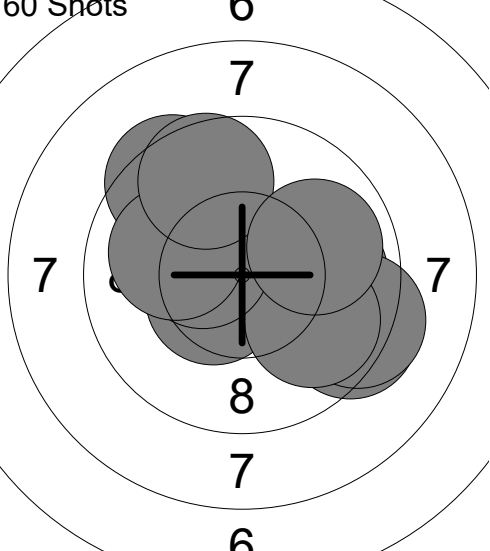
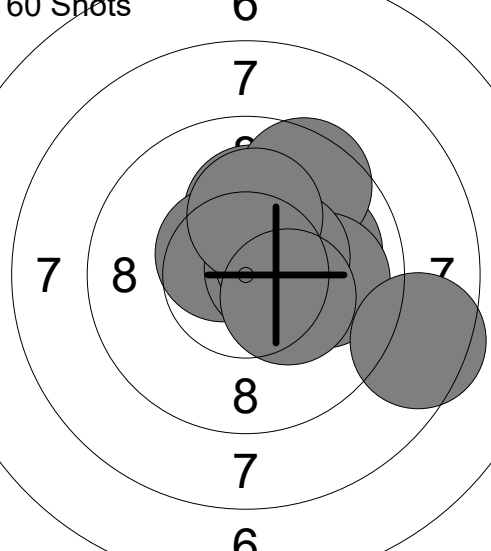
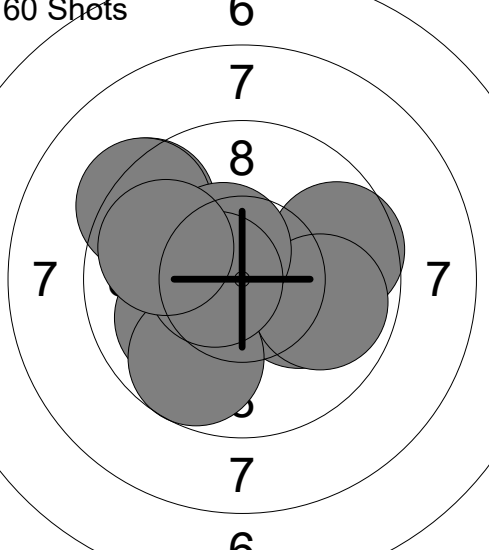
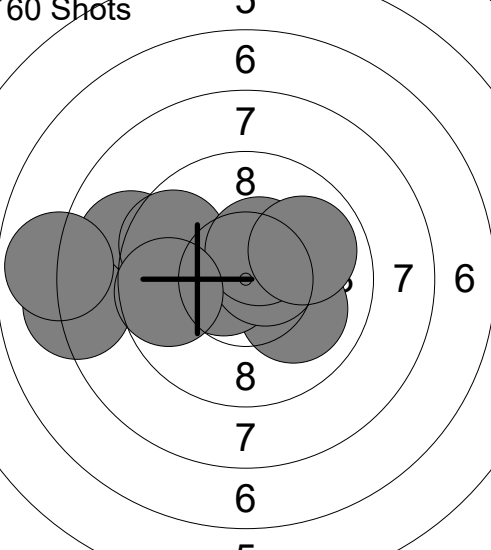
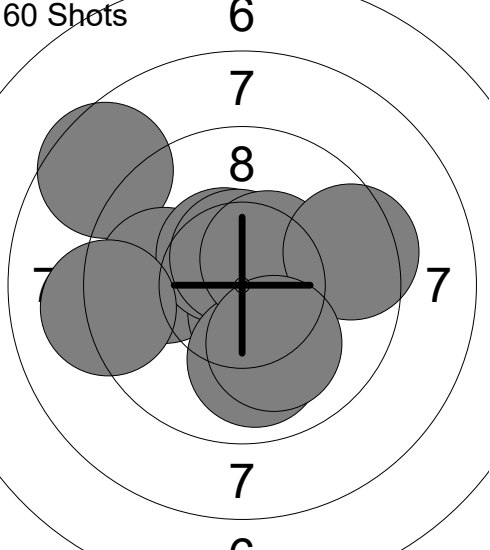
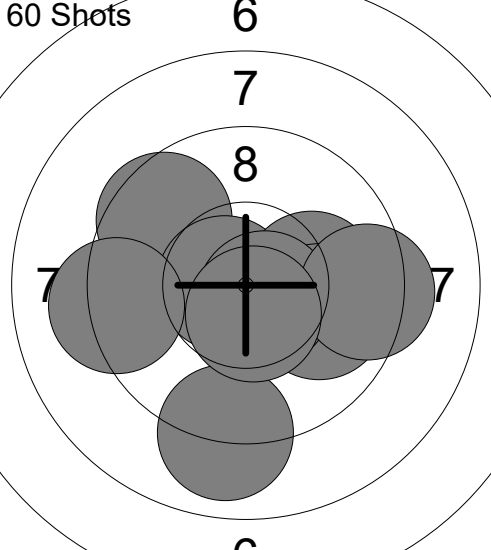
<p>60 Shots</p> 	<p>1: 10.5x ↙</p> <p>2: 9.3 ➤</p> <p>3: 9.9 ➔</p> <p>4: 9.3 ➤</p> <p>5: 9.9 ↘</p> <p>6: 10.4x ↖</p> <p>7: 9.4 ↗</p> <p>8: 10.0 ↖</p> <p>9: 9.6 ↗</p> <p>10: 9.9 ➔</p> <hr/> <p>Series 98.2</p> <hr/> <p>98.2</p>	<p>60 Shots</p> 	<p>11: 10.0 ➔</p> <p>12: 10.1 ↑</p> <p>13: 10.5x ↖</p> <p>14: 9.5 ↗</p> <p>15: 9.9 ➔</p> <p>16: 10.6x ➔</p> <p>17: 10.4x ↗</p> <p>18: 10.2x ↑</p> <p>19: 10.3x ➤</p> <p>20: 8.5 ➤</p> <hr/> <p>Series 100.0</p> <hr/> <p>198.2</p>
<p>60 Shots</p> 	<p>21: 10.1 ➤</p> <p>22: 9.6 ➔</p> <p>23: 9.9 ➤</p> <p>24: 10.0 ↖</p> <p>25: 9.4 ↗</p> <p>26: 9.3 ↗</p> <p>27: 9.7 ↘</p> <p>28: 10.5x ↗</p> <p>29: 10.6x ↖</p> <p>30: 9.9 ↖</p> <hr/> <p>Series 99.0</p> <hr/> <p>297.2</p>	<p>60 Shots</p> 	<p>31: 9.0 ↖</p> <p>32: 10.0 ➤</p> <p>33: 10.6x ↖</p> <p>34: 9.6 ↖</p> <p>35: 10.6x ➔</p> <p>36: 8.1 ↖</p> <p>37: 10.4x ↗</p> <p>38: 9.9 ➔</p> <p>39: 9.7 ↖</p> <p>40: 7.9 ↖</p> <hr/> <p>Series 95.8</p> <hr/> <p>393.0</p>
<p>60 Shots</p> 	<p>41: 8.6 ↖</p> <p>42: 9.9 ↖</p> <p>43: 10.6x ↘</p> <p>44: 10.5x ↗</p> <p>45: 10.6x ↗</p> <p>46: 9.2 ↖</p> <p>47: 10.0 ↘</p> <p>48: 10.5x ↗</p> <p>49: 9.4 ➔</p> <p>50: 10.1 ↘</p> <hr/> <p>Series 99.4</p> <hr/> <p>492.4</p>	<p>60 Shots</p> 	<p>51: 9.6 ↖</p> <p>52: 10.7x ↖</p> <p>53: 10.3x ➤</p> <p>54: 10.1 ➔</p> <p>55: 9.9 ➤</p> <p>56: 10.6x ↘</p> <p>57: 9.2 ↖</p> <p>58: 9.0 ↘</p> <p>59: 9.3 ➔</p> <p>60: 10.6x ↘</p> <hr/> <p>Series 99.3</p> <hr/> <p>591.7</p>

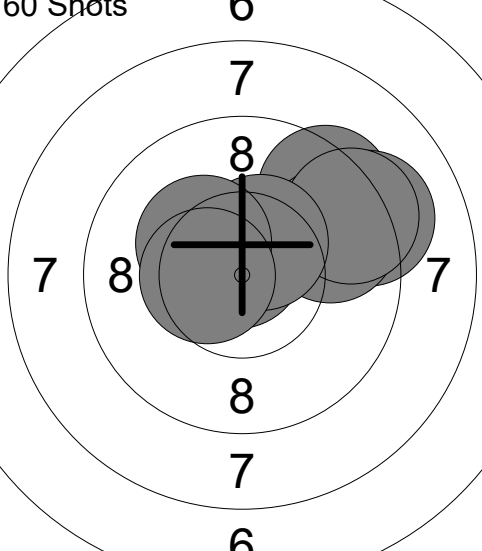
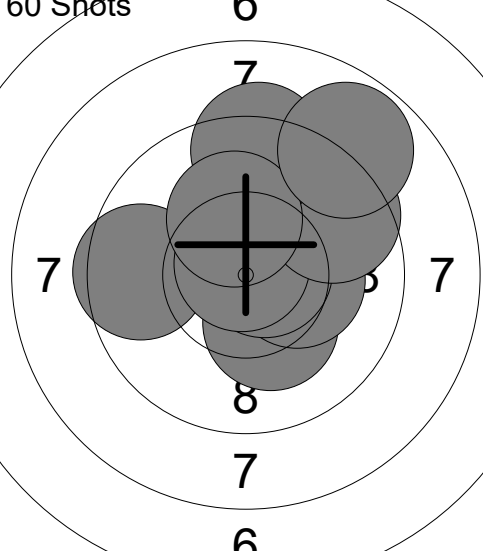
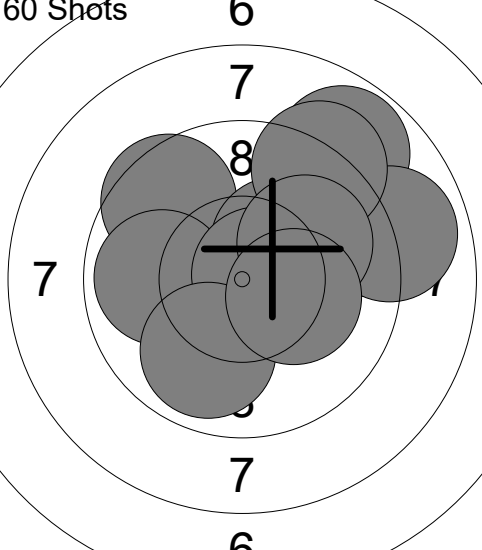
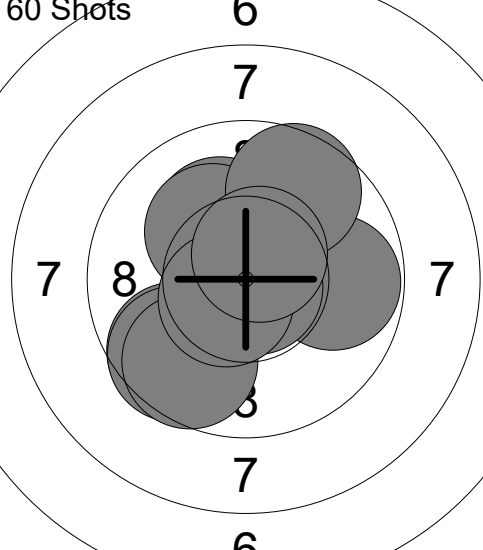
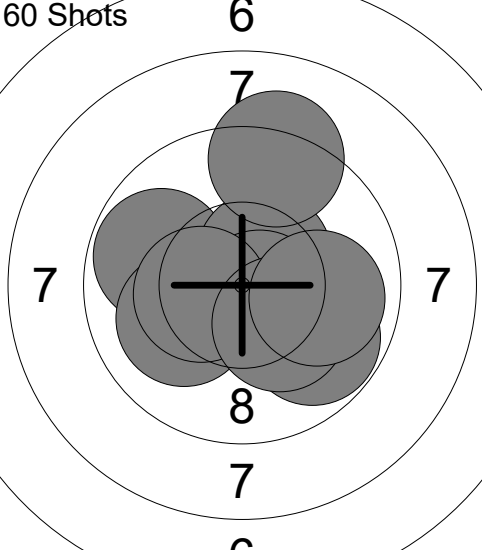
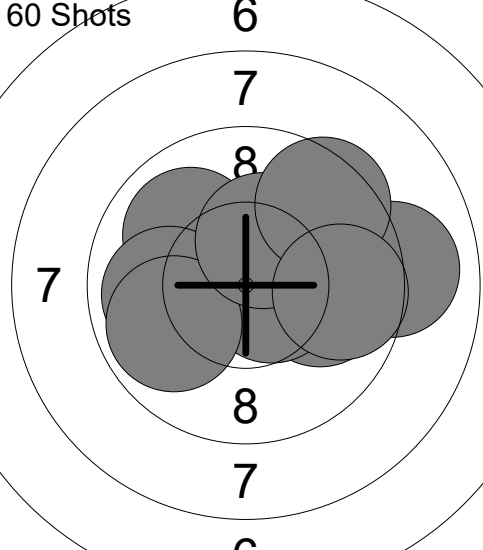
<p>60 Shots</p>  <p style="text-align: center;">6 7 8 7 8 7 7 8 7 7</p>	<p>1: 10.7x ↗</p> <p>2: 9.4 ↗</p> <p>3: 10.5x ↖</p> <p>4: 10.6x ↖</p> <p>5: 9.1 →</p> <p>6: 9.7 →</p> <p>7: 9.3 →</p> <p>8: 10.5x ↗</p> <p>9: 10.3x ↖</p> <p>10: 10.5x ←</p> <hr/> <p>Series 100.6</p>	<p>60 Shots</p>  <p style="text-align: center;">6 7 8 7 8 7 7 8 7 7</p>	<p>11: 10.2x ↘</p> <p>12: 10.3x →</p> <p>13: 9.8 ↗</p> <p>14: 10.7x →</p> <p>15: 9.6 ←</p> <p>16: 10.8x ↗</p> <p>17: 9.6 ↗</p> <p>18: 9.3 ↗</p> <p>19: 10.2x ↗</p> <p>20: 8.8 ↗</p> <hr/> <p>Series 99.3</p>
6 6	21: 9.5 ↖	6 6	31: 9.8 →
<p>60 Shots</p>  <p style="text-align: center;">6 7 8 7 8 7 7 8 7 7</p>	<p>22: 10.3x ↗</p> <p>23: 8.8 ↗</p> <p>24: 9.9 ←</p> <p>25: 8.9 →</p> <p>26: 9.2 ↗</p> <p>27: 10.7x →</p> <p>28: 10.0 →</p> <p>29: 9.9 ↘</p> <p>30: 10.2x →</p> <hr/> <p>Series 97.4</p>	<p>60 Shots</p>  <p style="text-align: center;">6 7 8 7 8 7 7 8 7 7</p>	<p>32: 10.2x ↗</p> <p>33: 10.2x ↖</p> <p>34: 9.6 ↗</p> <p>35: 9.6 ↘</p> <p>36: 9.6 ↘</p> <p>37: 9.6 ↘</p> <p>38: 10.8x ↘</p> <p>39: 10.6x ↘</p> <p>40: 10.6x ↗</p> <hr/> <p>Series 100.6</p>
6 6	297.3	6 6	397.9
<p>60 Shots</p>  <p style="text-align: center;">6 7 8 7 8 7 7 8 7 7</p>	<p>41: 9.8 ←</p> <p>42: 10.1 ←</p> <p>43: 10.9x →</p> <p>44: 10.5x ↗</p> <p>45: 9.8 ↘</p> <p>46: 9.2 ↗</p> <p>47: 10.7x ↘</p> <p>48: 10.4x ←</p> <p>49: 10.2x ↘</p> <p>50: 9.9 →</p> <hr/> <p>Series 101.5</p>	<p>60 Shots</p>  <p style="text-align: center;">6 7 8 7 8 7 7 8 7 7</p>	<p>51: 10.4x ←</p> <p>52: 10.0 ↖</p> <p>53: 9.9 ←</p> <p>54: 10.0 →</p> <p>55: 9.0 →</p> <p>56: 10.6x →</p> <p>57: 9.9 ←</p> <p>58: 10.3x ↗</p> <p>59: 9.5 ↗</p> <p>60: 9.7 →</p> <hr/> <p>Series 99.3</p>
6	499.4	6	598.7

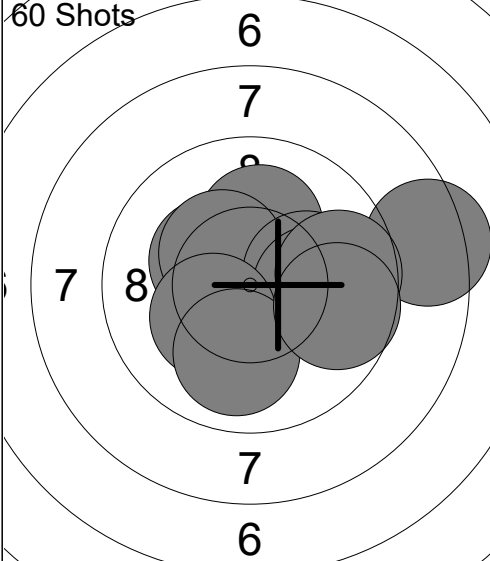
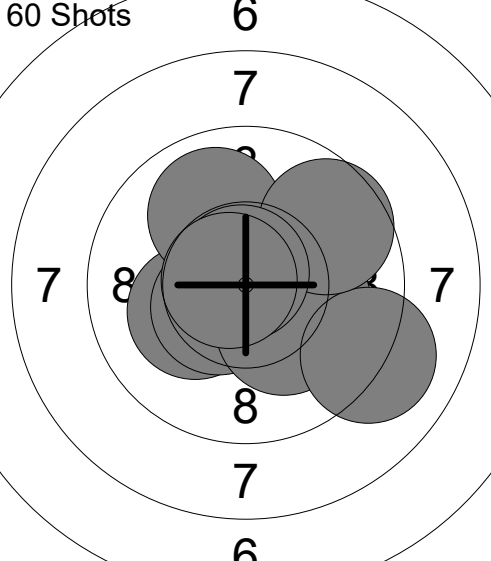
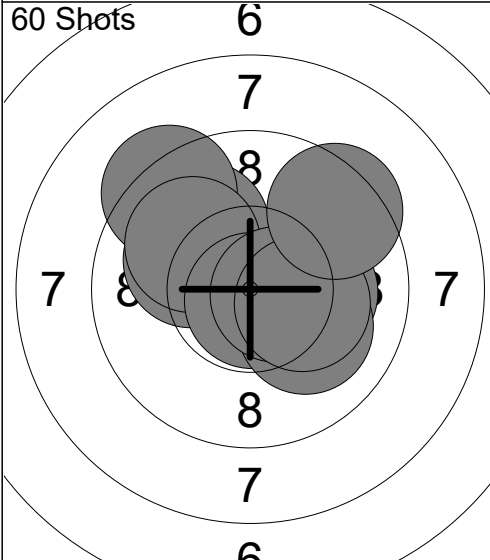
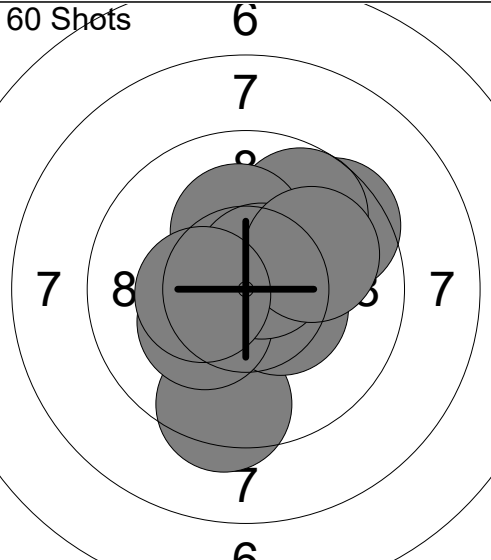
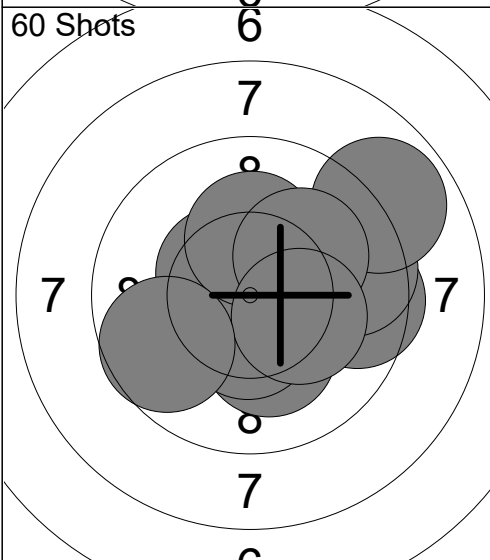
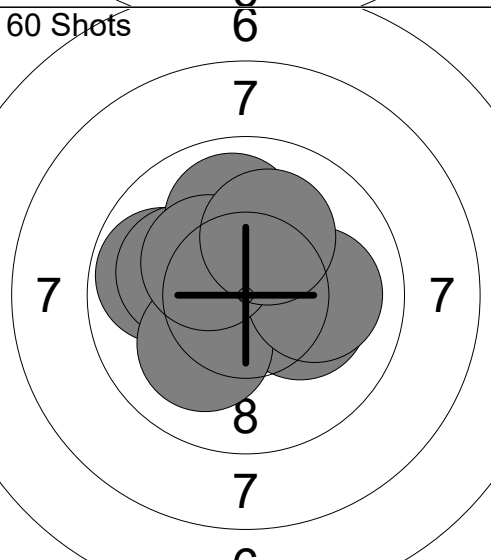
<p>60 Shots</p>  <p style="text-align: center;">6 7 8 7 6</p>	<p>1: 10.3x ↖ 2: 10.1 ↑ 3: 10.4x ↗ 4: 8.4 → 5: 10.1 → 6: 10.0 → 7: 10.3x ↙ 8: 10.0 ↓ 9: 9.7 → 10: 9.7 →</p> <p>Series 99.0 99.0</p>	<p>60 Shots</p>  <p style="text-align: center;">6 7 8 7 6</p>	<p>11: 10.8x ↘ 12: 10.2x ↙ 13: 10.1 → 14: 10.5x ↙ 15: 10.2x ↘ 16: 9.9 ↑ 17: 9.1 → 18: 9.6 ↗ 19: 10.8x ↑ 20: 10.7x ↙</p> <p>Series 101.9 200.9</p>
<p>60 Shots</p>  <p style="text-align: center;">6 7 8 7 6</p>	<p>21: 9.9 ↗ 22: 9.3 ↗ 23: 10.1 ↗ 24: 10.0 ↗ 25: 10.2x → 26: 10.8x ↓ 27: 10.1 ↘ 28: 10.6x → 29: 10.2x → 30: 9.4 ↗</p> <p>Series 100.6 301.5</p>	<p>60 Shots</p>  <p style="text-align: center;">6 7 8 7 6</p>	<p>31: 10.8x ↙ 32: 9.4 ↓ 33: 9.5 ↗ 34: 9.7 ↗ 35: 10.2x ↑ 36: 10.4x → 37: 10.3x ↙ 38: 10.6x ↗ 39: 10.0 ↗ 40: 10.4x ↙</p> <p>Series 101.3 402.8</p>
<p>60 Shots</p>  <p style="text-align: center;">6 7 8 7 6</p>	<p>41: 9.5 → 42: 10.2x ↓ 43: 10.5x ↓ 44: 10.5x ↖ 45: 10.2x ↑ 46: 9.6 → 47: 8.9 ↗ 48: 10.1 ↗ 49: 10.2x → 50: 9.7 ↙</p> <p>Series 99.4 502.2</p>	<p>60 Shots</p>  <p style="text-align: center;">6 7 8 7 6</p>	<p>51: 10.8x ↓ 52: 10.4x ↙ 53: 10.2x → 54: 9.8 ← 55: 10.1 ← 56: 9.9 ↑ 57: 10.1 ↙ 58: 10.0 → 59: 10.3x ↖ 60: 10.1 ↑</p> <p>Series 101.7 603.9</p>

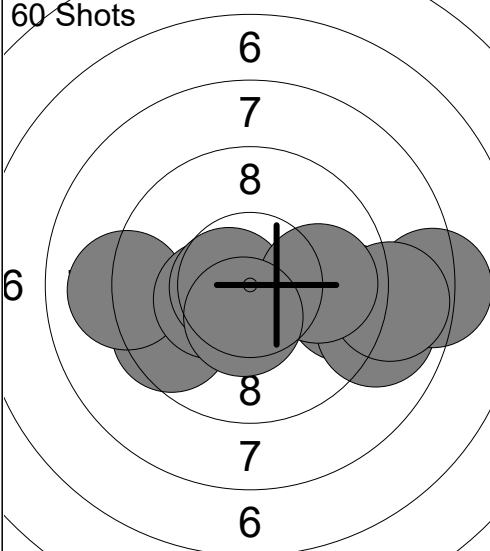
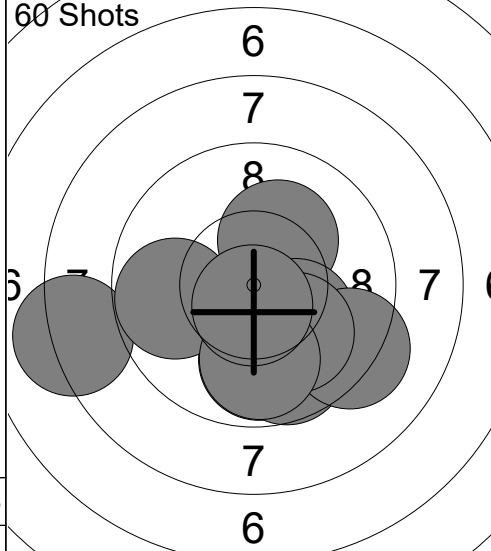
<p>60 Shots</p>  <p style="text-align: center;">6 7 8 8 7 6</p> <p style="text-align: center;">Series 95.4 95.4</p>	<p>1: 9.5 → 2: 9.6 ← 3: 9.1 ← 4: 10.3x ← 5: 8.9 → 6: 8.2 → 7: 8.8 → 8: 10.6x ← 9: 9.9 → 10: 10.5x ↓</p> <p style="text-align: center;">Series 95.4 95.4</p>	<p>60 Shots</p>  <p style="text-align: center;">6 7 8 8 7 6</p> <p style="text-align: center;">Series 97.6 193.0</p>	<p>11: 9.8 ↓ 12: 10.2x ↗ 13: 8.2 ← 14: 9.8 ← 15: 9.7 ↓ 16: 10.2x ↓ 17: 9.2 ↘ 18: 10.0 ↓ 19: 9.9 ↓ 20: 10.6x ↓</p> <p style="text-align: center;">Series 97.6 193.0</p>
---	---	--	--

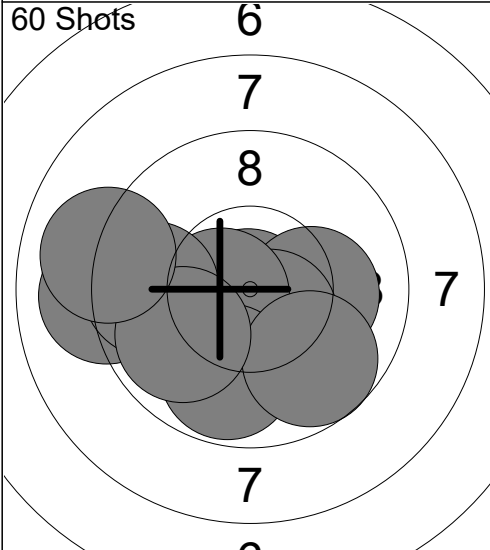
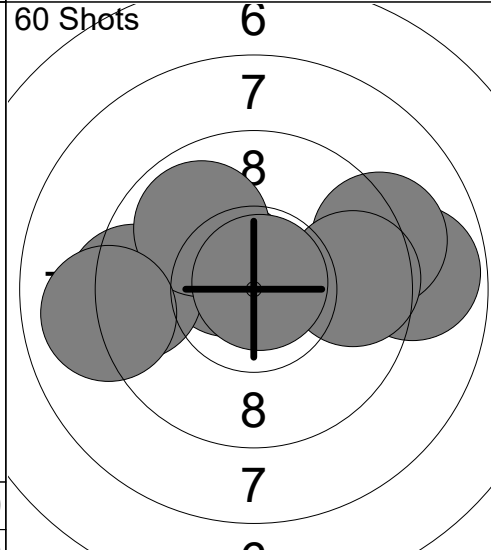
<p>60 Shots</p>  <p style="text-align: center;">6 7 8 7 7</p> <p style="text-align: center;">Series 99.0 292.0</p>	<p>21: 10.8x ↓ 22: 10.1 → 23: 10.5x ↓ 24: 9.0 ← 25: 10.6x ← 26: 9.8 ↓ 27: 9.6 ← 28: 9.7 ↓ 29: 9.9 ← 30: 9.0 ←</p> <p style="text-align: center;">Series 99.0 292.0</p>	<p>60 Shots</p>  <p style="text-align: center;">6 7 8 8 7 6</p> <p style="text-align: center;">Series 97.5 389.5</p>	<p>31: 10.2x ← 32: 8.8 → 33: 10.1 ← 34: 10.5x ↖ 35: 9.2 → 36: 9.4 ← 37: 9.9 ↗ 38: 9.0 ← 39: 9.6 → 40: 10.8x ↗</p> <p style="text-align: center;">Series 97.5 389.5</p>
---	--	---	--

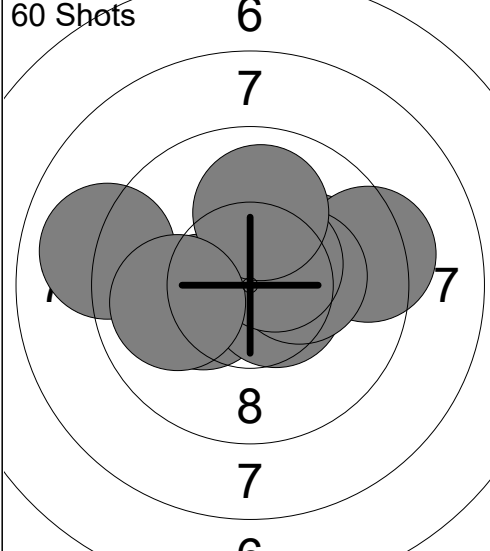
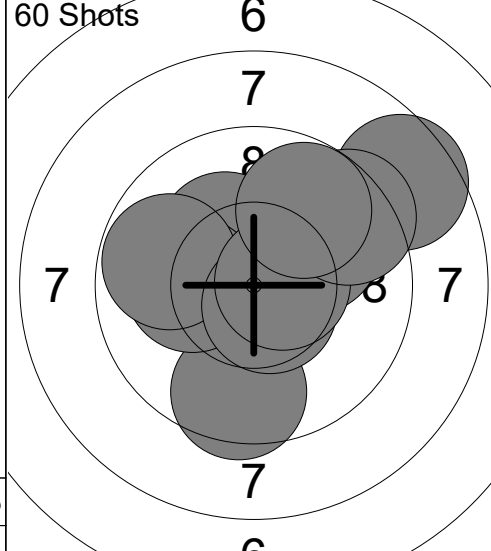
<p>60 Shots</p>  <p style="text-align: center;">6 7 8 7 6</p> <p style="text-align: center;">Series 100.8 490.3</p>	<p>41: 10.7x → 42: 10.3x ← 43: 10.6x ↘ 44: 10.1 → 45: 9.3 → 46: 9.0 ← 47: 10.3x → 48: 10.5x ↗ 49: 10.0 ↑ 50: 10.0 ←</p> <p style="text-align: center;">Series 100.8 490.3</p>	<p>60 Shots</p>  <p style="text-align: center;">6 7 8 8 7 6</p> <p style="text-align: center;">Series 98.6 588.9</p>	<p>51: 9.5 ↓ 52: 10.2x ↖ 53: 10.0 ↗ 54: 10.1 ← 55: 9.8 ← 56: 10.6x ↓ 57: 8.6 ↗ 58: 10.6x → 59: 9.4 ↗ 60: 9.8 ↗</p> <p style="text-align: center;">Series 98.6 588.9</p>
---	---	--	---

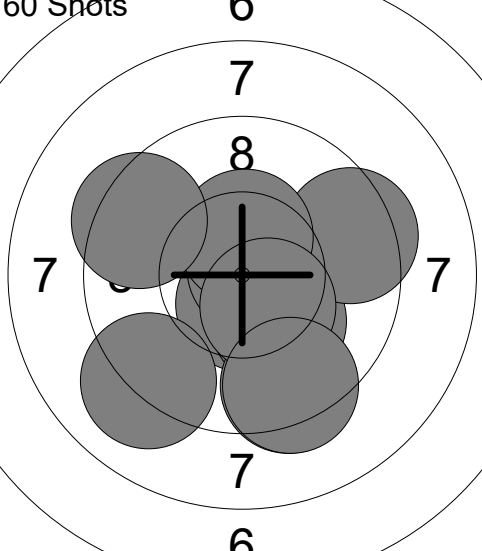
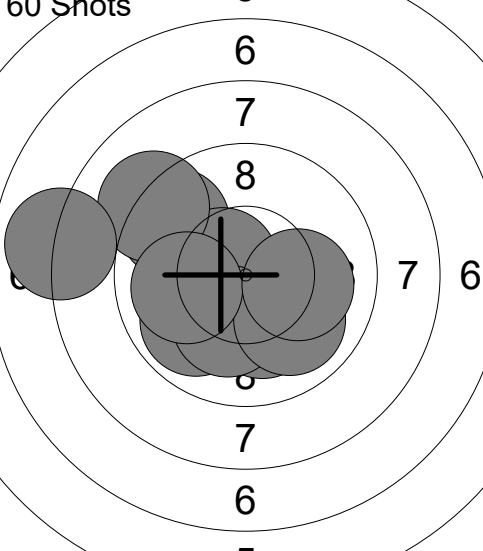
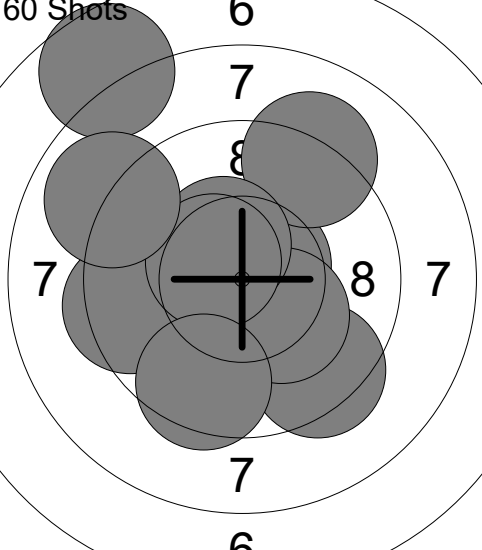
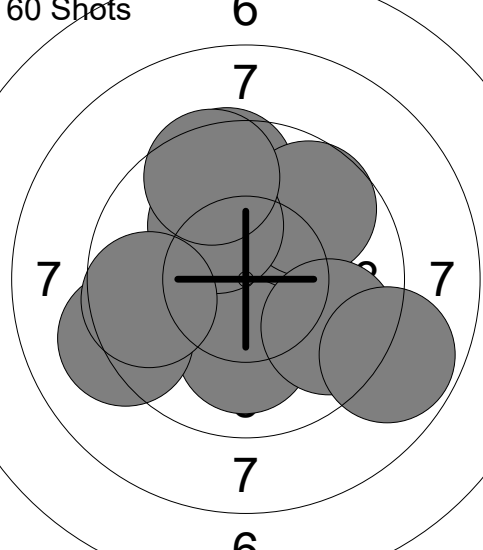
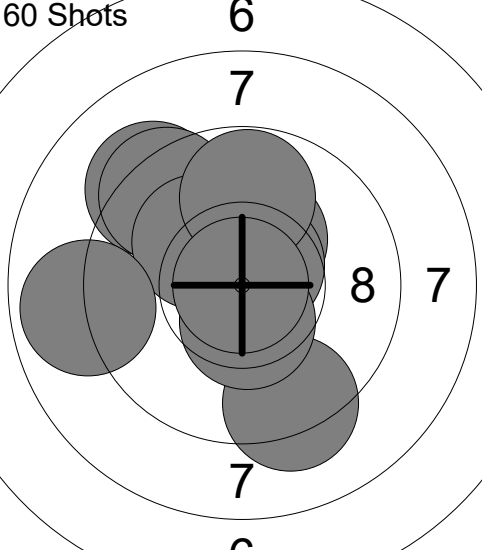
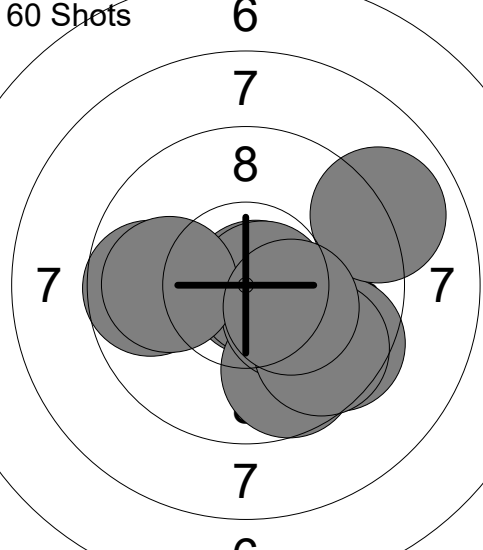
<p>60 Shots</p> 	<p>1: 10.6x ↓ 2: 10.2x ↓ 3: 10.8x ↗ 4: 9.4 → 5: 9.4 ↓ 6: 9.1 ↙ 7: 10.4x ↑ 8: 10.4x ↓ 9: 9.4 ↖ 10: 9.4 ↓</p> <p>Series 99.1 99.1</p>	<p>60 Shots</p> 	<p>11: 9.5 ↗ 12: 10.1 ↓ 13: 9.9 ↙ 14: 10.5x ↖ 15: 9.1 ↗ 16: 7.9 ← 17: 10.2x ↓ 18: 9.9 ↓ 19: 10.0 ← 20: 10.1 →</p> <p>Series 97.2 196.3</p>
<p>60 Shots</p> 	<p>21: 9.4 ↓ 22: 10.6x ↗ 23: 9.1 ↑ 24: 7.7 ↗ 25: 9.4 ← 26: 10.2x ↓ 27: 10.4x ↗ 28: 10.5x ↖ 29: 8.9 ↖ 30: 9.5 ↓</p> <p>Series 95.7 292.0</p>	<p>60 Shots</p> 	<p>31: 10.3x ⇒ 32: 9.6 ↑ 33: 10.1 ↓ 34: 9.7 ↗ 35: 10.1 ↗ 36: 9.2 ← 37: 9.7 ⇒ 38: 9.5 ↑ 39: 9.6 ← 40: 8.8 ⇒</p> <p>Series 96.6 388.6</p>
<p>60 Shots</p> 	<p>41: 9.2 ↗ 42: 9.4 ↗ 43: 10.3x ↑ 44: 9.3 ↓ 45: 10.6x ↗ 46: 10.1 ↗ 47: 10.5x ↓ 48: 9.8 ↑ 49: 8.9 ← 50: 10.9x ←</p> <p>Series 99.0 487.6</p>	<p>60 Shots</p> 	<p>51: 9.7 ← 52: 10.8x ⇒ 53: 10.7x ⇒ 54: 9.7 ↓ 55: 9.5 ↓ 56: 10.3x ⇒ 57: 9.9 ← 58: 9.6 ↓ 59: 9.0 ↗ 60: 10.3x ⇒</p> <p>Series 99.5 587.1</p>

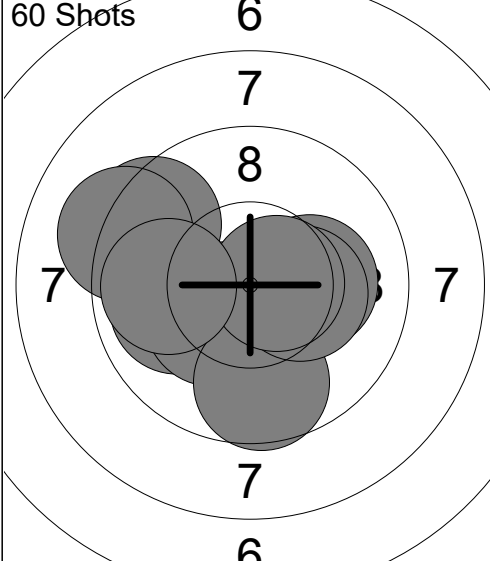
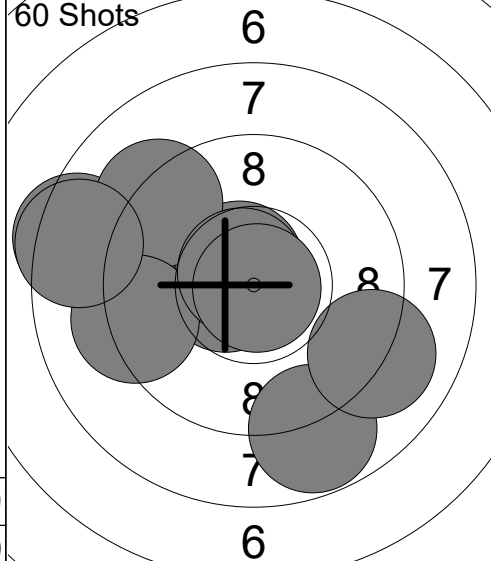
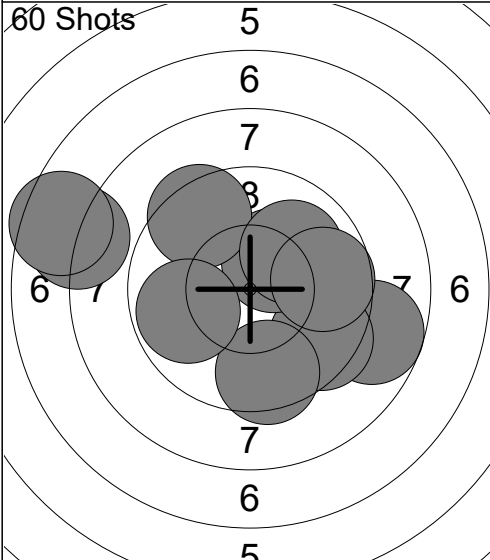
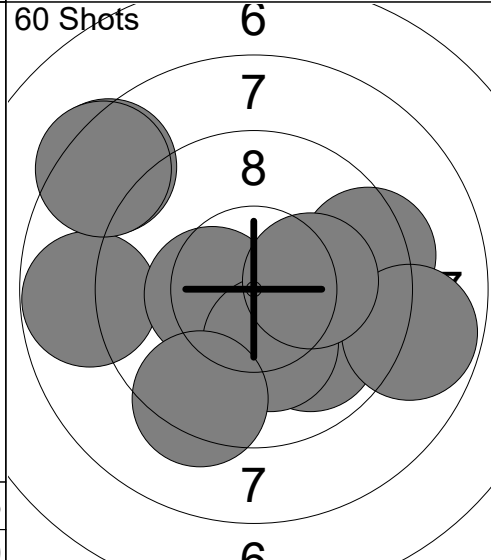
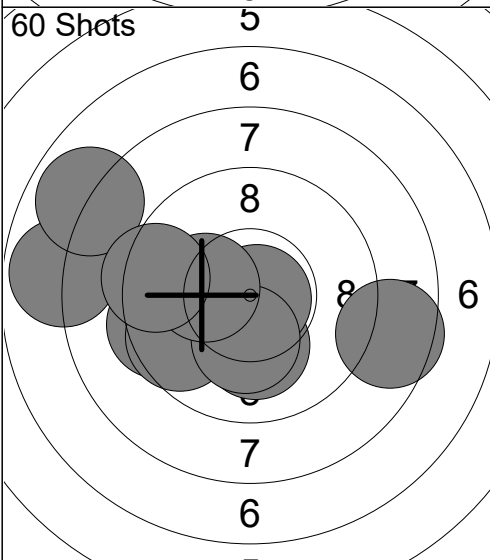
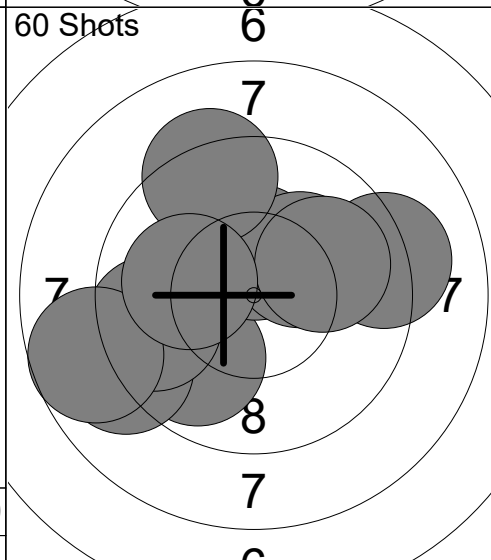
<p>60 Shots</p>  <p style="text-align: center;">6 7 8 7</p>	<p>1: 10.4x ↙ 2: 10.2x → 3: 10.0 ← 4: 9.4 ↖ 5: 10.3x ↙ 6: 9.6 ↓ 7: 10.3x → 8: 9.2 ↖ 9: 10.6x → 10: 9.9 ←</p> <p>Series 99.9</p> <p style="text-align: center;">99.9</p>	<p>60 Shots</p>  <p style="text-align: center;">6 7 8 7</p>	<p>11: 10.6x ← 12: 8.8 ↓ 13: 10.6x ↗ 14: 8.4 ← 15: 9.2 ↗ 16: 9.2 ← 17: 9.0 ↘ 18: 8.4 ← 19: 10.7x ↗ 20: 10.9x ↘</p> <p>Series 95.8</p> <p style="text-align: center;">195.7</p>
<p>60 Shots</p>  <p style="text-align: center;">6 5 6 7 8 7 6</p>	<p>21: 7.9 ← 22: 8.7 → 23: 9.5 ↘ 24: 10.3x ↗ 25: 9.5 ↓ 26: 7.5 ← 27: 9.4 ↗ 28: 10.0 ↗ 29: 9.8 ← 30: 9.7 →</p> <p>Series 92.3</p> <p style="text-align: center;">288.0</p>	<p>60 Shots</p>  <p style="text-align: center;">6 7 8 7</p>	<p>31: 8.8 ← 32: 9.9 ↓ 33: 10.4x ← 34: 10.2x ↓ 35: 9.4 → 36: 8.4 ↗ 37: 8.8 → 38: 8.4 ↗ 39: 10.2x → 40: 9.3 ↓</p> <p>Series 93.8</p> <p style="text-align: center;">381.8</p>
<p>60 Shots</p>  <p style="text-align: center;">5 6 7 8 7 6 5</p>	<p>41: 9.4 ← 42: 9.6 ← 43: 7.8 ← 44: 10.1 ↓ 45: 10.8x ↘ 46: 8.6 → 47: 10.2x ↓ 48: 7.9 ↖ 49: 10.2x ← 50: 9.4 ←</p> <p>Series 94.0</p> <p style="text-align: center;">475.8</p>	<p>60 Shots</p>  <p style="text-align: center;">6 7 8 7 6</p>	<p>51: 9.8 ↙ 52: 9.0 ← 53: 9.2 → 54: 9.6 ← 55: 10.4x ↑ 56: 10.2x ↗ 57: 10.0 → 58: 8.7 ← 59: 9.3 ↑ 60: 10.1 ←</p> <p>Series 96.3</p> <p style="text-align: center;">572.1</p>

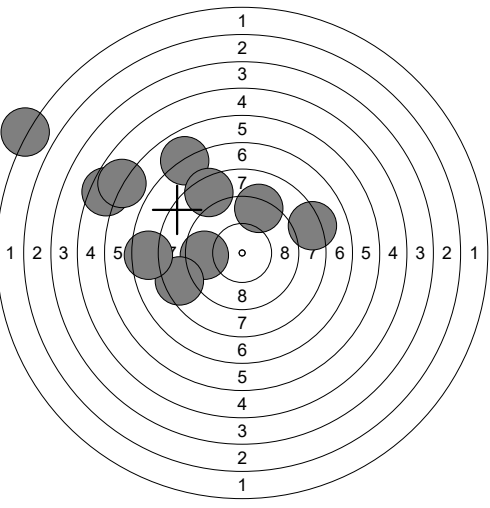
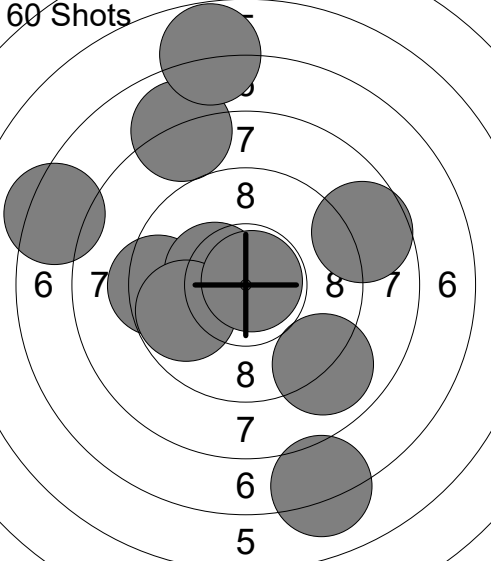
<p>60 Shots</p> 	<p>1: 6.9 ↗ 2: 9.2 ↑ 3: 5.4 ← 4: 9.5 ← 5: 8.1 → 6: 5.8 ↖ 7: 8.4 ← 8: 1.7 ↖ 9: 7.5 ← 10: 8.4 ↗</p> <p>Series 70.9 70.9</p>	<p>60 Shots</p> 	<p>11: 8.0 ↗ 12: 9.4 ← 13: 10.3x ← 14: 6.8 ↑ 15: 7.3 ← 16: 8.7 → 17: 9.0 ↘ 18: 9.8 ← 19: 7.1 ↘ 20: 10.8x ↗</p> <p>Series 87.2 158.1</p>
--	---	--	---

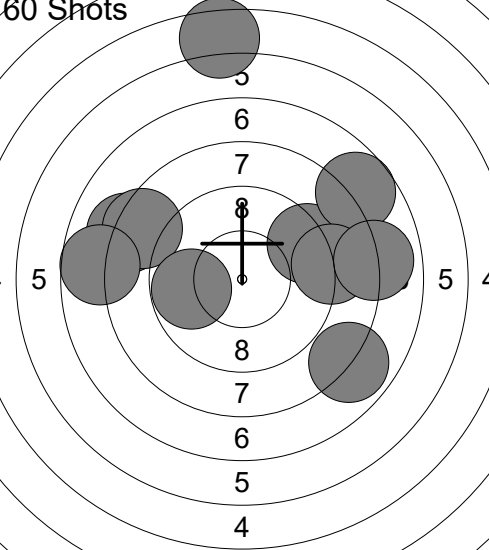
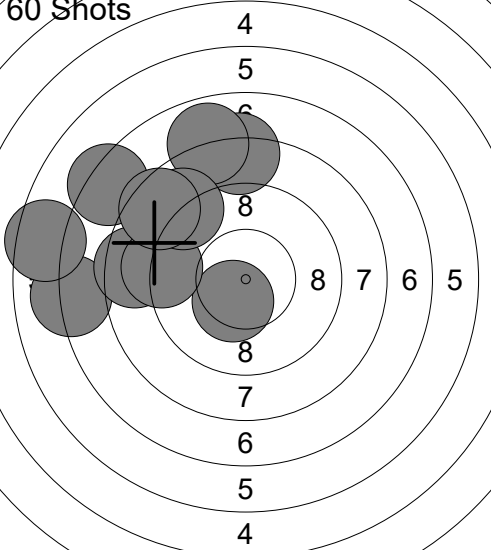
<p>60 Shots</p> 	<p>21: 8.1 ← 22: 8.4 ← 23: 5.5 ↑ 24: 9.3 → 25: 7.7 → 26: 8.9 → 27: 7.9 ↘ 28: 8.0 → 29: 7.7 ← 30: 9.8 ←</p> <p>Series 81.3 239.4</p>	<p>60 Shots</p> 	<p>31: 8.2 ↑ 32: 7.9 ↑ 33: 7.1 ← 34: 8.5 ← 35: 7.3 ↖ 36: 6.5 ← 37: 10.4x ↘ 38: 9.1 ← 39: 8.9 ↗ 40: 8.5 ↖</p> <p>Series 82.4 321.8</p>
---	---	---	---

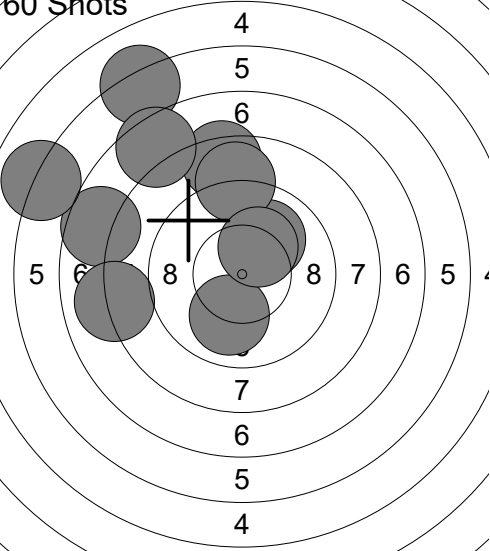
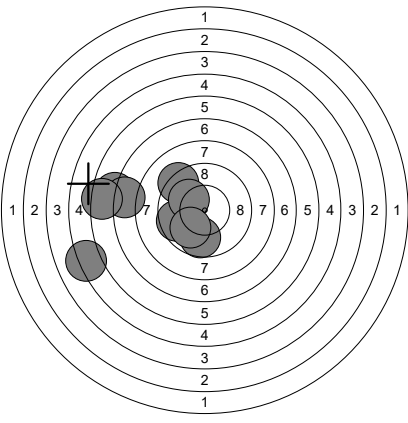
<p>60 Shots</p> 	<p>41: 10.0 ↗ 42: 7.6 ← 43: 8.0 ← 44: 8.4 ↑ 45: 10.0 ↘ 46: 6.2 ↗ 47: 8.9 ↑ 48: 6.0 ← 49: 7.5 ↗ 50: 10.2x ↗</p> <p>Series 82.8 404.6</p>	<p>60 Shots</p> 	<p>51: 0.0 ← 52: 6.8 ← 53: 9.2 ↗ 54: 9.7 ↘ 55: 9.6 ← 56: 10.1 ↖ 57: 7.3 ← 58: 5.2 ← 59: 6.3 ← 60: 9.9 ↘</p> <p>Series 74.1 478.7</p>
--	---	--	--

Relay 3	Lane 16	GUEVARA Anderson
-------------------	-------------------	-------------------------

1-80	Marion 1	Precision	
------	----------	-----------	--

31.01.2025	2025 AirNats by X Count	Civilian Marksmanship Program	
------------	-------------------------	-------------------------------	--

Comment	Signature		
---------	-----------	--	--

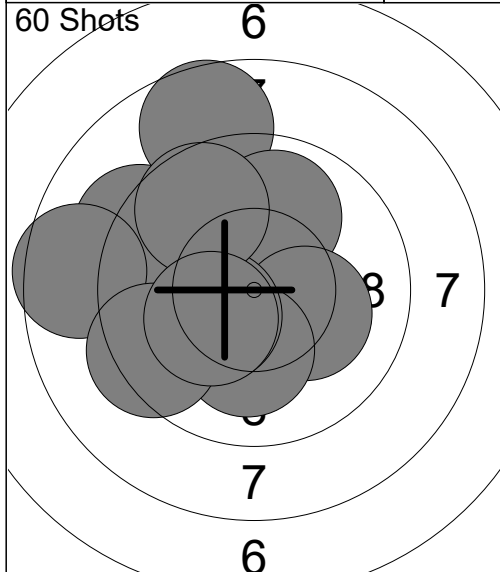

1:	8.7	↑
2:	9.2	↖
3:	9.9	↑
4:	10.2x	↘
5:	8.6	←
6:	10.1	↓
7:	10.3x	↙
8:	9.7	↗
9:	9.4	↖
10:	10.3x	↙
Series	96.4	
	96.4	

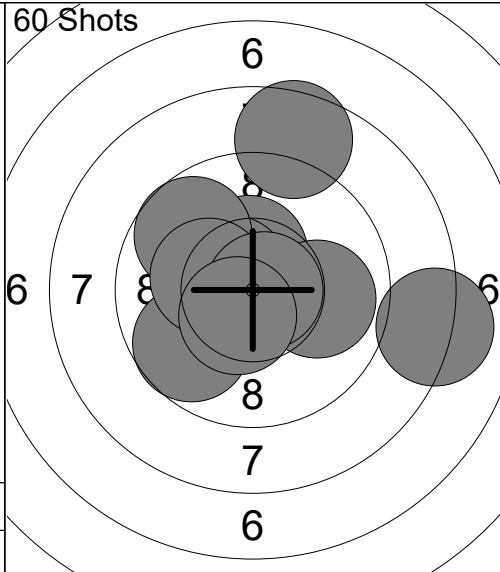

11:	10.4x	↑
12:	10.0	→
13:	8.6	↑
14:	10.5x	↖
15:	8.1	→
16:	9.7	↙
17:	9.7	↖
18:	10.3x	↖
19:	10.8x	→
20:	10.5x	↙
Series	98.6	
	195.0	

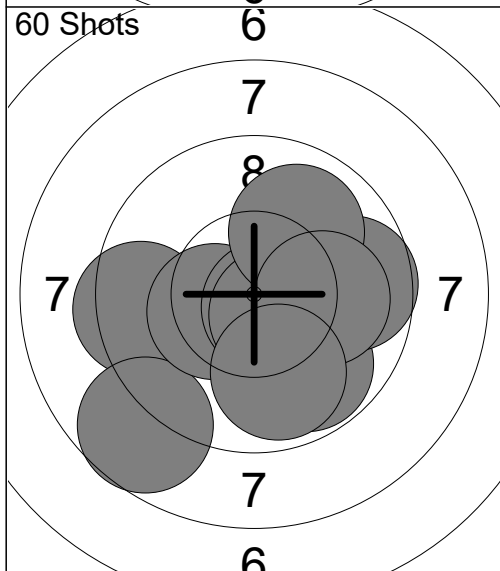

21:	9.4	←
22:	8.7	↙
23:	9.8	↘
24:	10.4x	↙
25:	10.7x	↘
26:	9.7	→
27:	10.5x	↘
28:	10.0	↗
29:	10.0	→
30:	9.9	↓
Series	99.1	
	294.1	

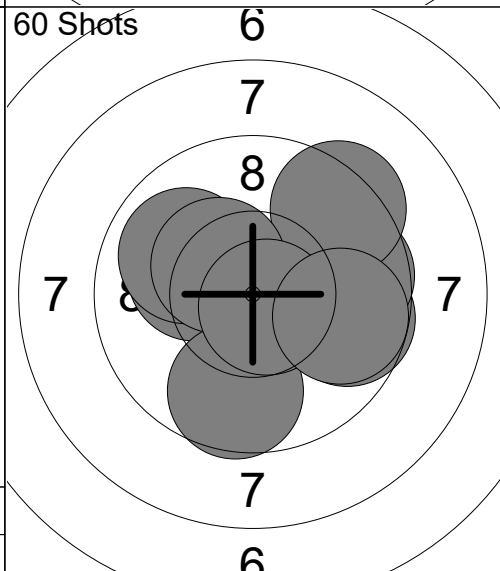

31:	10.2x	→
32:	10.1	↖
33:	9.9	↖
34:	9.7	→
35:	9.7	→
36:	9.7	↓
37:	9.3	↗
38:	10.4x	↖
39:	10.7x	↘
40:	9.8	→
Series	99.5	
	393.6	

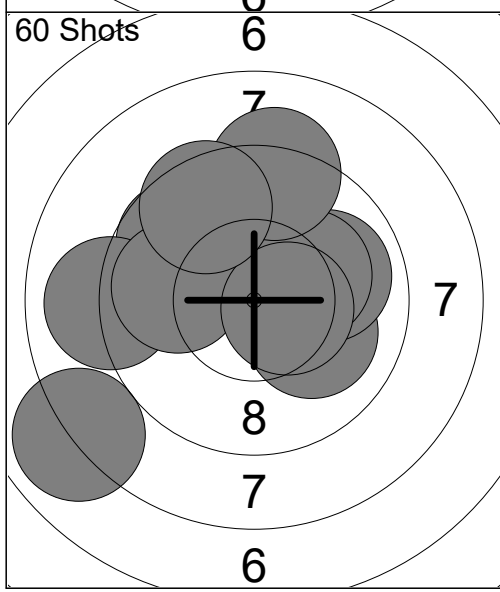

41:	8.0	↙
42:	10.1	↘
43:	9.7	↗
44:	9.9	→
45:	9.0	←
46:	10.2x	↗
47:	9.9	←
48:	9.2	↑
49:	10.5x	→
50:	9.5	↗
Series	96.0	
	489.6	

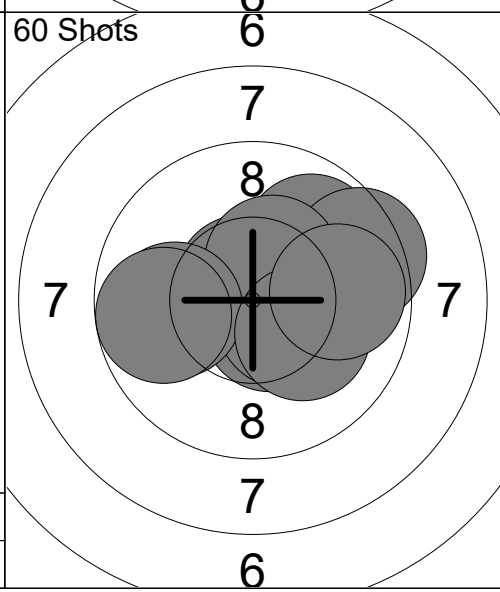

51:	9.9	↗
52:	10.6x	↘
53:	10.7x	↗
54:	9.4	→
55:	10.5x	↘
56:	10.4x	↗
57:	9.9	←
58:	9.8	←
59:	10.2x	↘
60:	9.8	→
Series	101.2	
	590.8	

Relay	Lane	PURDY Nicholas						
3	17							

1-80	Marion 1	Precision	
------	----------	-----------	--

31.01.2025	2025 AirNats by X Count	Civilian Marksmanship Program		
------------	-------------------------	-------------------------------	--	--

Comment	Signature			
---------	-----------	--	--	--

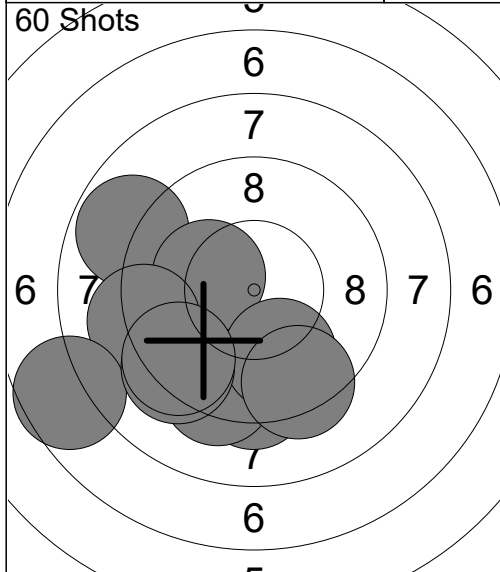

1: 8.8 ↖
2: 10.2x ↖
3: 9.3 ↓
4: 9.3 ↓
5: 9.8 ↓
6: 9.1 ←
7: 7.6 ←
8: 9.2 ↙
9: 9.3 ↙
10: 9.3 ↓
Series 91.9
91.9

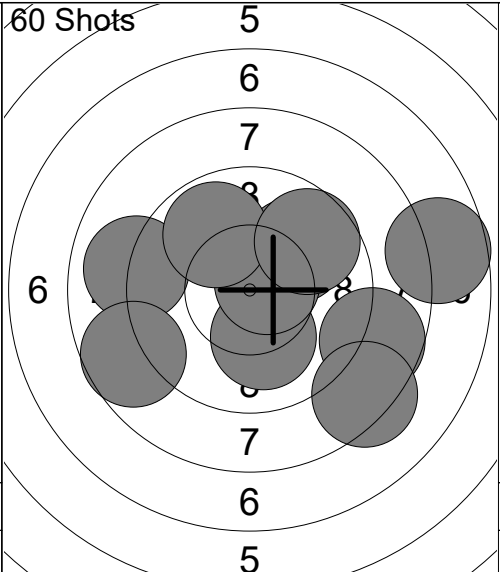

11: 7.7 →
12: 9.0 ←
13: 10.0 ↗
14: 8.7 →
15: 10.1 ↓
16: 8.3 ↓
17: 10.6x →
18: 9.8 ↗
19: 9.7 ↗
20: 8.7 ←
Series 92.6
184.5

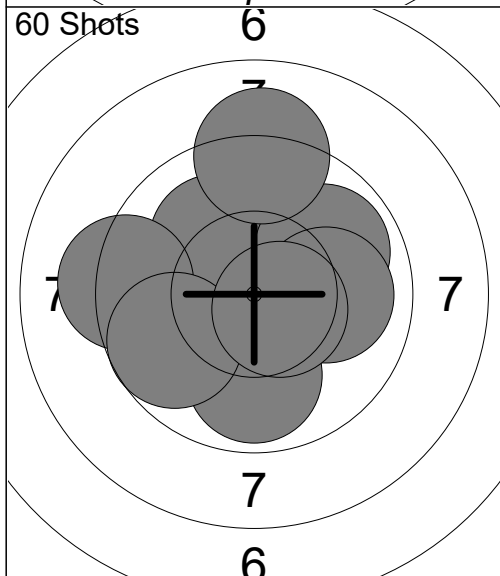

21: 10.5x ↑
22: 9.9 ↓
23: 10.5x ←
24: 10.1 ↗
25: 9.9 ↗
26: 10.0 →
27: 9.2 ←
28: 9.7 ←
29: 10.6x →
30: 9.1 ↑
Series 99.5
284.0

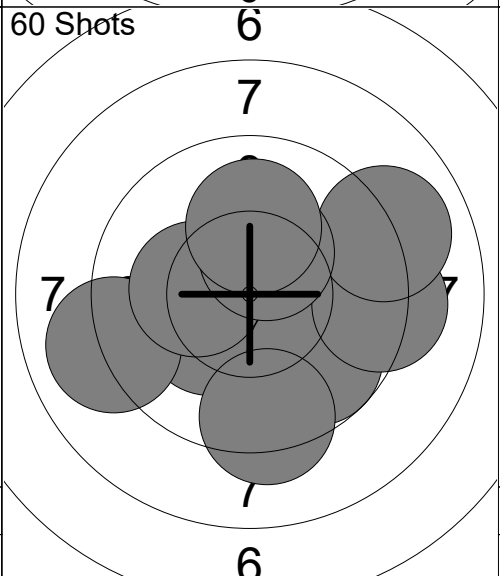

31: 10.3x ↙
32: 9.0 ←
33: 9.5 →
34: 9.7 ↓
35: 9.3 ↓
36: 10.2x ←
37: 9.2 →
38: 9.0 ↗
39: 10.4x ↑
40: 10.1 ↑
Series 96.7
380.7

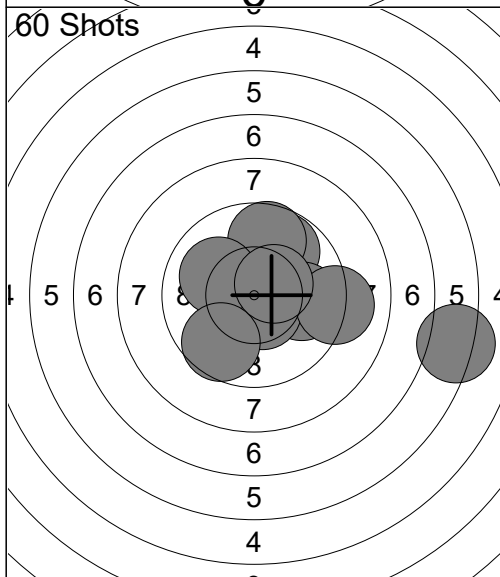

41: 9.8 ↗
42: 9.9 →
43: 10.6x ←
44: 10.6x ↓
45: 9.7 ↑
46: 9.1 →
47: 6.2 →
48: 10.0 ←
49: 9.6 ↓
50: 10.4x ↗
Series 95.9
476.6

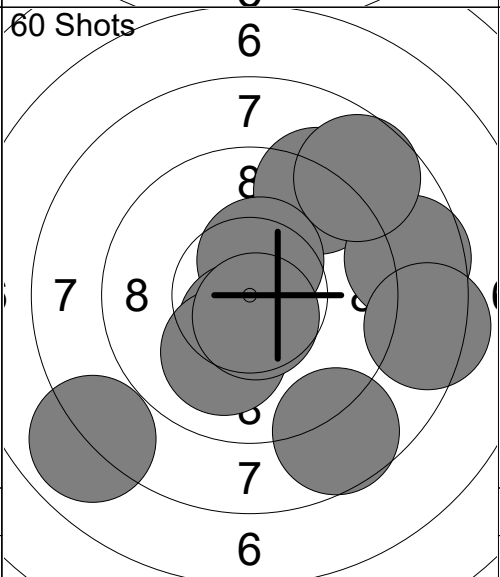

51: 9.2 ↗
52: 7.9 ↙
53: 8.7 →
54: 8.4 →
55: 8.7 ↓
56: 10.4x ↑
57: 10.5x ↓
58: 8.7 ↗
59: 10.1 ↓
60: 10.6x ↓
Series 93.2
569.8

Relay 3	Lane 18	PURDY Danielle
-------------------	-------------------	-----------------------

1-80	Marion 1	Precision	
------	----------	-----------	--

31.01.2025	2025 AirNats by X Count	Civilian Marksmanship Program	
------------	-------------------------	-------------------------------	--

Comment	Signature		
---------	-----------	--	--

<p>60 Shots</p>	<p>1: 10.6x ↓ 2: 10.4x ↗ 3: 9.4 ← 4: 8.9 ↙ 5: 9.7 ↙ 6: 9.2 ↙ 7: 9.7 ↙ 8: 9.3 ← 9: 10.2x ↗ 10: 10.0 →</p> <p>Series 97.4 97.4</p>	<p>60 Shots</p>	<p>11: 9.2 → 12: 10.6x ↓ 13: 9.7 ← 14: 9.6 ↓ 15: 8.5 ← 16: 9.3 → 17: 10.2x ↗ 18: 9.7 ↘ 19: 10.0 ← 20: 8.7 →</p> <p>Series 95.5 192.9</p>
<p>60 Shots</p>	<p>21: 8.8 ← 22: 10.1 → 23: 8.7 ↙ 24: 10.3x ← 25: 9.8 ↙ 26: 9.6 → 27: 10.1 ↑ 28: 10.5x ↖ 29: 10.4x ↑ 30: 10.2x ←</p> <p>Series 98.5 291.4</p>	<p>60 Shots</p>	<p>31: 8.3 ↖ 32: 10.7x ↓ 33: 9.7 → 34: 9.8 ↗ 35: 10.2x ↖ 36: 10.1 ↑ 37: 8.8 ↘ 38: 10.2x ← 39: 10.6x ↓ 40: 10.6x →</p> <p>Series 99.0 390.4</p>
<p>60 Shots</p>	<p>41: 9.8 ↓ 42: 10.1 → 43: 9.8 ← 44: 10.2x ↑ 45: 10.0 ↗ 46: 10.6x ↘ 47: 10.5x ↗ 48: 10.0 ↖ 49: 10.0 ↖ 50: 9.0 ↘</p> <p>Series 100.0 490.4</p>	<p>60 Shots</p>	<p>51: 10.3x ↙ 52: 9.5 → 53: 10.2x ↓ 54: 9.8 ← 55: 10.0 ← 56: 9.6 ↗ 57: 10.0 ↑ 58: 9.5 ↗ 59: 9.9 ↑ 60: 10.1 ↖</p> <p>Series 98.9 589.3</p>

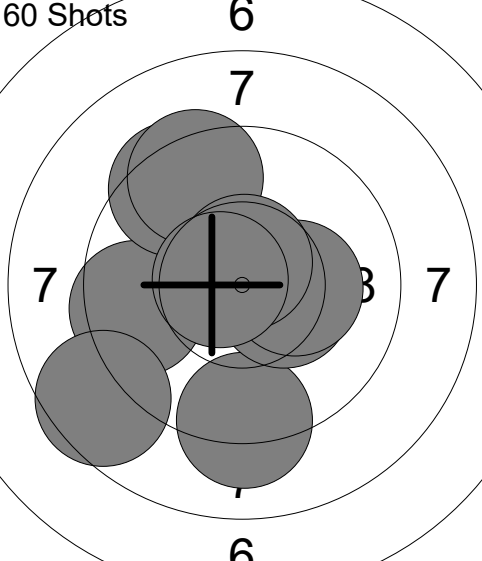
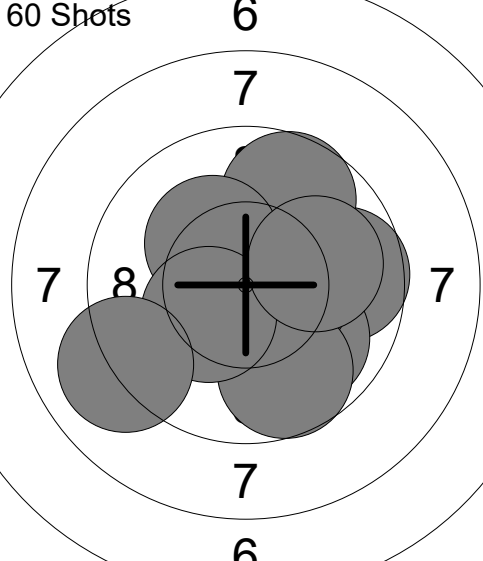
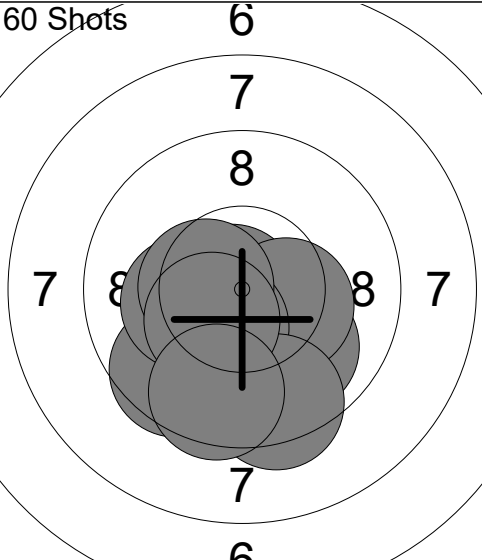
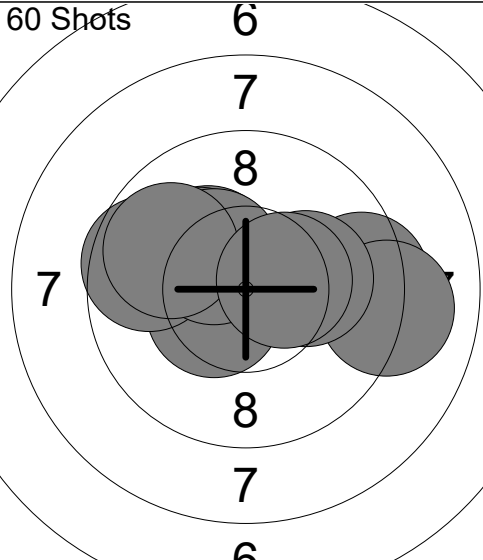
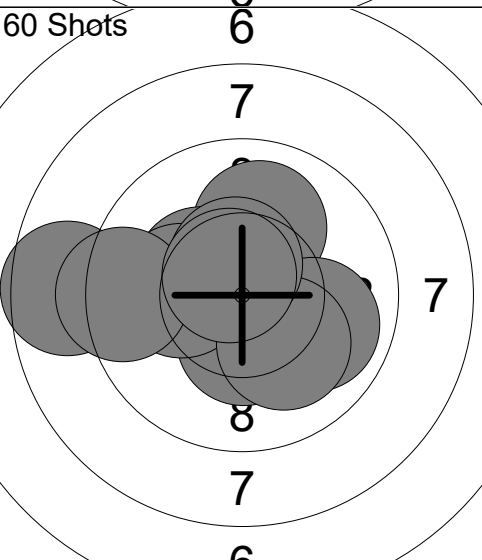
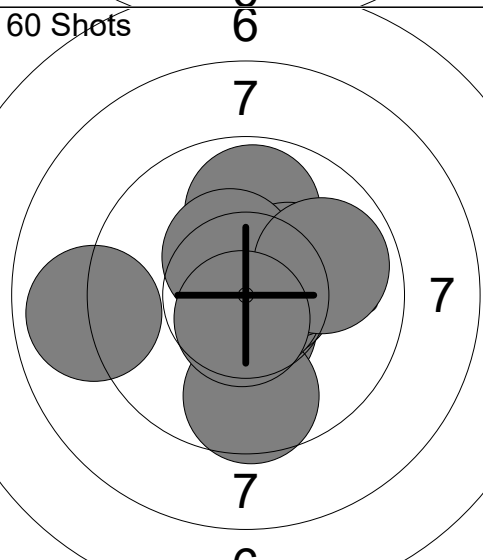
<p>60 Shots</p> 	<p>1: 9.2 ↓ 2: 10.4x → 3: 10.5x ← 4: 9.5 ← 5: 9.4 ↗ 6: 8.6 ↙ 7: 10.3x → 8: 9.4 ↗ 9: 10.6x ↑ 10: 10.7x ←</p> <p>Series 98.6 98.6</p>	<p>60 Shots</p> 	<p>11: 10.6x ↙ 12: 9.7 → 13: 9.9 ↘ 14: 10.4x → 15: 9.7 ↘ 16: 9.7 ↗ 17: 10.2x ↗ 18: 10.3x ↙ 19: 10.0 → 20: 9.0 ↙</p> <p>Series 99.5 198.1</p>
<p>60 Shots</p> 	<p>21: 9.9 ↘ 22: 10.8x ← 23: 10.3x → 24: 9.6 ↘ 25: 10.4x ↘ 26: 9.4 ↘ 27: 10.2x ← 28: 10.5x ← 29: 10.4x ↙ 30: 9.5 ↘</p> <p>Series 101.0 299.1</p>	<p>60 Shots</p> 	<p>31: 9.4 → 32: 10.3x ↖ 33: 10.2x ↖ 34: 9.1 → 35: 10.1 → 36: 10.5x ↙ 37: 9.6 ← 38: 10.3x ↖ 39: 9.8 ↖ 40: 10.4x →</p> <p>Series 99.7 398.8</p>
<p>60 Shots</p> 	<p>41: 10.0 ↑ 42: 10.3x ↖ 43: 9.9 → 44: 10.4x ↘ 45: 10.1 ← 46: 10.1 ↘ 47: 10.5x ↑ 48: 8.6 ← 49: 9.3 ← 50: 10.6x ↗</p> <p>Series 99.8 498.6</p>	<p>60 Shots</p> 	<p>51: 10.5x ↘ 52: 8.9 ← 53: 9.6 ↘ 54: 10.6x → 55: 9.9 ↑ 56: 10.8x ↘ 57: 10.3x ↗ 58: 10.4x ↗ 59: 9.9 → 60: 10.6x ↘</p> <p>Series 101.5 600.1</p>

Relay 3	Lane 20	ALLEN Khamrynn
-------------------	-------------------	-----------------------

1-80	Marion 1	Precision	
------	----------	-----------	--

31.01.2025	2025 AirNats by X Count	Civilian Marksmanship Program	
------------	-------------------------	-------------------------------	--

Comment	Signature		
---------	-----------	--	--

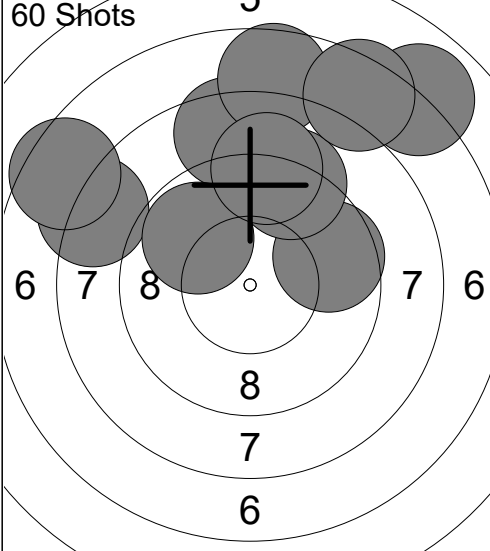
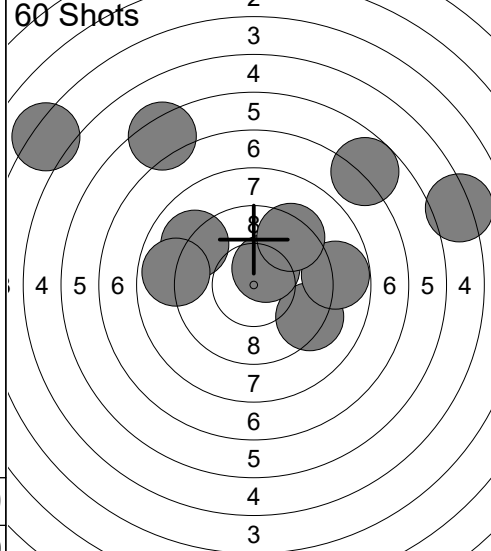
<p>60 Shots</p>  <p style="text-align: center;">8 7 6</p>	<p>1: 9.6 → 2: 8.2 ← 3: 9.2 ↑ 4: 7.5 ← 5: 6.9 ↗ 6: 8.5 ↑ 7: 7.6 ↑ 8: 7.5 ↗ 9: 9.8 ← 10: 9.1 ↑</p> <p>Series 83.9</p>	<p>60 Shots</p>  <p style="text-align: center;">8 7 6 5 4</p>	<p>11: 6.3 ↖ 12: 9.2 → 13: 10.4x ↗ 14: 6.7 ↗ 15: 8.8 → 16: 9.0 ← 17: 9.4 ↗ 18: 8.9 ← 19: 5.1 → 20: 4.2 ←</p> <p>Series 78.0</p>
83.9		161.9	

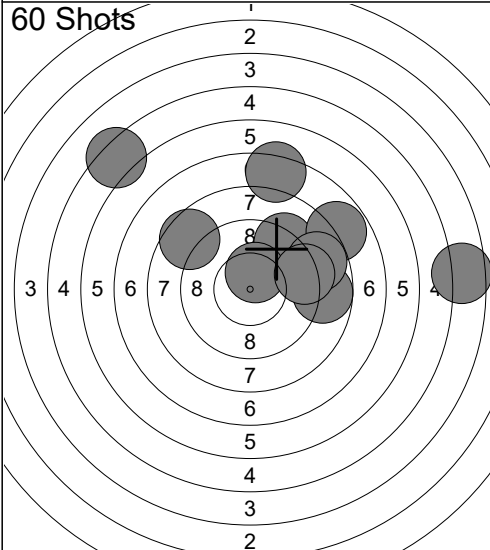
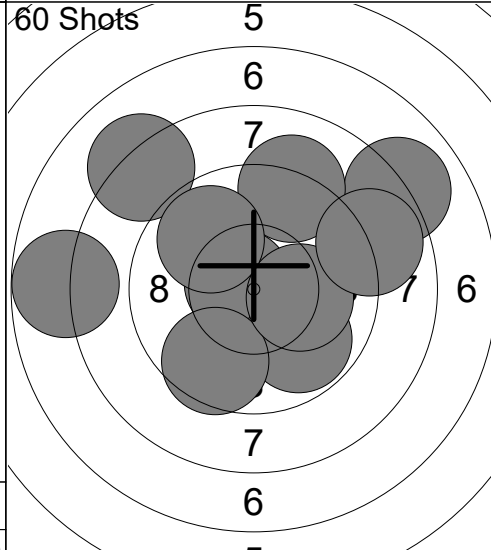
<p>60 Shots</p>  <p style="text-align: center;">8 7 6 5 4 3 2 1</p>	<p>21: 5.3 ↖ 22: 8.8 → 23: 9.2 ↗ 24: 7.8 ↗ 25: 10.4x ↑ 26: 8.8 → 27: 9.3 → 28: 7.3 ↑ 29: 8.6 ← 30: 4.6 →</p> <p>Series 80.1</p>	<p>60 Shots</p>  <p style="text-align: center;">8 7 6 5</p>	<p>31: 8.0 ↗ 32: 10.7x ← 33: 9.1 ↑ 34: 9.8 ↘ 35: 9.6 ↘ 36: 10.2x → 37: 8.8 → 38: 8.2 ↗ 39: 9.8 ↗ 40: 7.8 ←</p> <p>Series 92.0</p>
242.0		334.0	

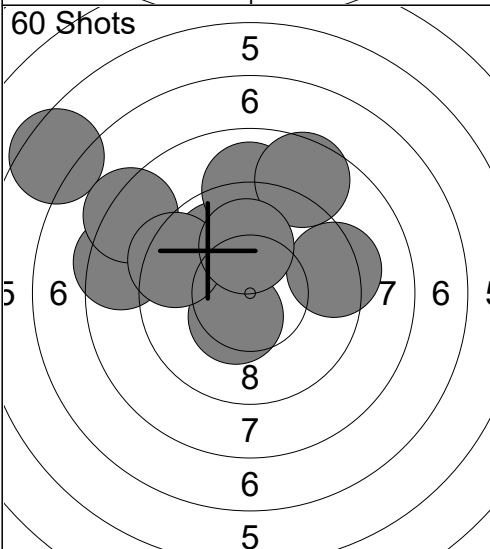
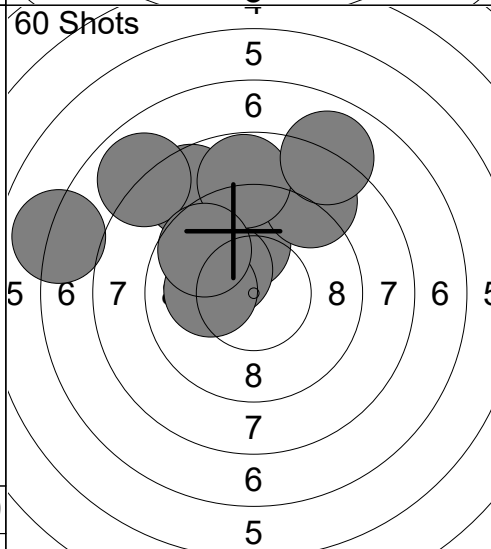
<p>60 Shots</p>  <p style="text-align: center;">8 7 6 5</p>	<p>41: 9.9 ↖ 42: 8.4 ← 43: 6.5 ↖ 44: 9.3 → 45: 9.0 ↑ 46: 10.4x ↘ 47: 8.6 ↑ 48: 8.3 ↖ 49: 9.4 ← 50: 10.1 ↑</p> <p>Series 89.9</p>	<p>60 Shots</p>  <p style="text-align: center;">8 7 6 5</p>	<p>51: 10.0 ↑ 52: 8.6 ↖ 53: 7.0 ← 54: 8.9 ↗ 55: 7.9 ↖ 56: 10.2x ↖ 57: 8.8 ↑ 58: 10.1 ← 59: 9.7 ↖ 60: 8.0 ↗</p> <p>Series 89.2</p>
423.9		513.1	

Relay 3	Lane 21	RANEK Cyrus
-------------------	-------------------	--------------------

1-80	St. Louis University HS Blue	Precision	
------	------------------------------	-----------	--

31.01.2025	2025 AirNats by X Count	Civilian Marksmanship Program	
------------	-------------------------	-------------------------------	--

Comment	Signature		
---------	-----------	--	--

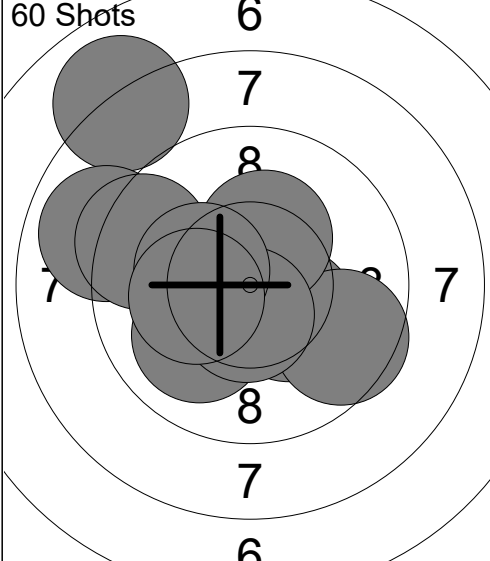
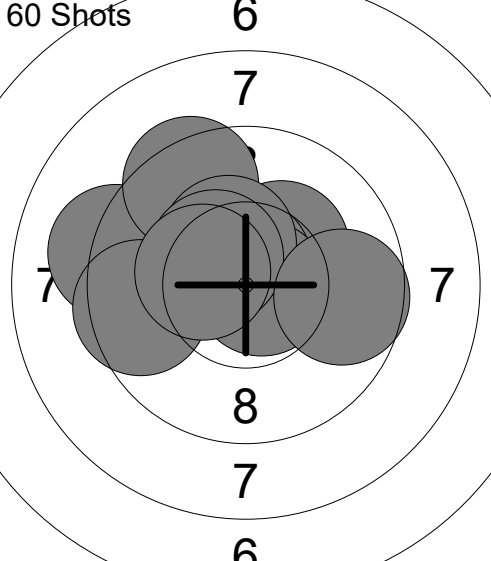
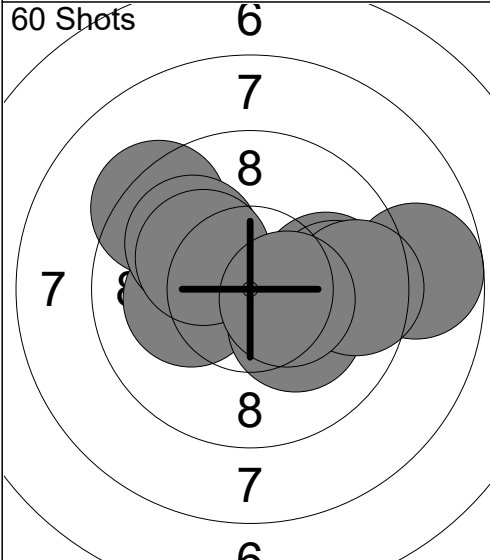
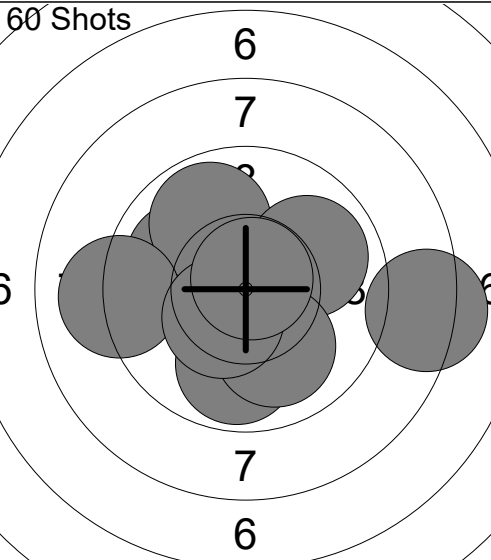
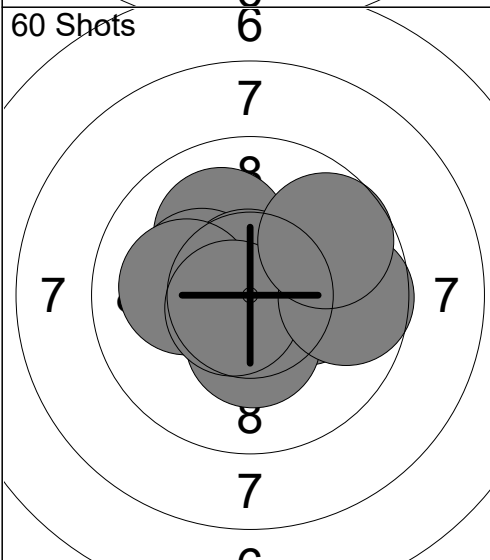
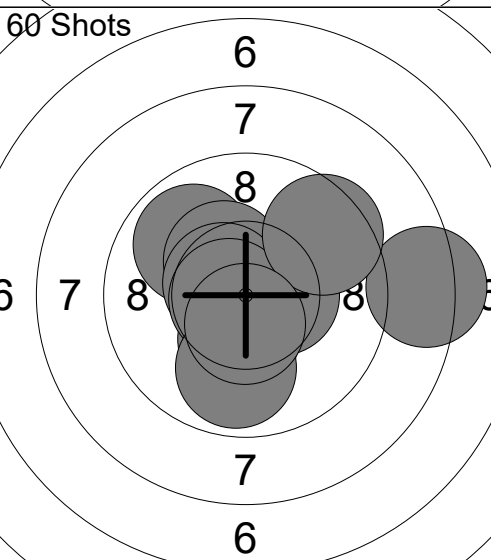
<p>60 Shots</p>  <p style="text-align: center;">6 7 8 7 7</p>	<p>1: 8.0 ↗ 2: 10.3x ↘ 3: 8.9 ← 4: 9.6 ↘ 5: 10.0 ↙ 6: 9.4 ← 7: 10.3x ↑ 8: 10.6x ↓ 9: 10.3x ← 10: 10.2x ←</p> <p>Series 97.6</p>	<p>60 Shots</p>  <p style="text-align: center;">6 7 8 7</p>	<p>11: 10.3x ↗ 12: 9.2 ← 13: 10.7x ↑ 14: 10.7x → 15: 9.4 ↗ 16: 10.4x ↑ 17: 10.4x ↖ 18: 9.5 ← 19: 10.4x ← 20: 9.7 →</p> <p>Series 100.7</p>
	97.6		198.3
<p>60 Shots</p>  <p style="text-align: center;">6 7 8 7</p>	<p>21: 10.2x ← 22: 9.9 → 23: 8.7 → 24: 9.8 → 25: 9.3 ↗ 26: 10.0 ↗ 27: 10.2x ↗ 28: 10.2x ↘ 29: 9.5 → 30: 10.4x →</p> <p>Series 98.2</p>	<p>60 Shots</p>  <p style="text-align: center;">6 7 8 7</p>	<p>31: 9.8 ↓ 32: 10.1 ↖ 33: 10.0 ← 34: 9.8 ↗ 35: 9.1 ← 36: 9.9 ↗ 37: 10.0 ↓ 38: 10.4x ↙ 39: 10.8x ↑ 40: 8.3 →</p> <p>Series 98.2</p>
	296.5		394.7
<p>60 Shots</p>  <p style="text-align: center;">6 7 8 7 6</p>	<p>41: 10.1 ↗ 42: 10.3x → 43: 10.2x → 44: 10.3x ← 45: 10.7x ↑ 46: 10.4x ↓ 47: 10.1 ← 48: 10.7x ↙ 49: 9.7 → 50: 9.7 ↗</p> <p>Series 102.2</p>	<p>60 Shots</p>  <p style="text-align: center;">6 7 8 7 6</p>	<p>51: 9.9 ↖ 52: 10.3x ↓ 53: 8.3 → 54: 10.4x ↖ 55: 10.5x → 56: 10.6x ↖ 57: 10.7x ← 58: 9.9 ↓ 59: 9.5 ↗ 60: 10.5x ↓</p> <p>Series 100.6</p>
	496.9		597.5

Relay 3	Lane 22	MILLER Liam
-------------------	-------------------	--------------------

1-80	St. Louis University HS Blue	Precision
------	------------------------------	-----------

31.01.2025	2025 AirNats by X Count	Civilian Marksmanship Program
------------	-------------------------	-------------------------------

Comment	Signature
---------	-----------

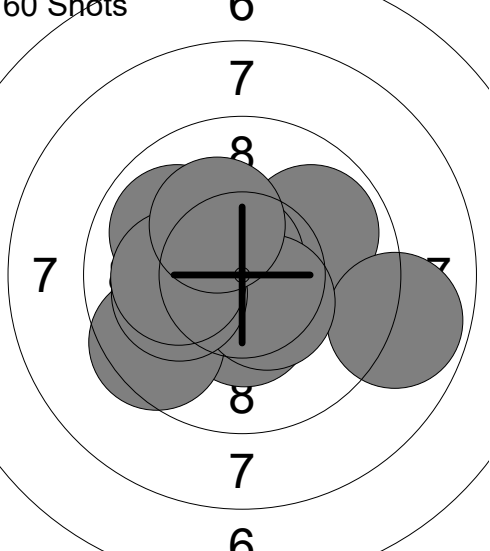
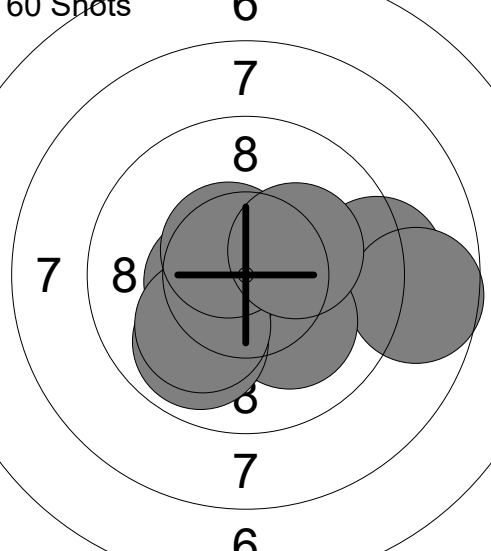
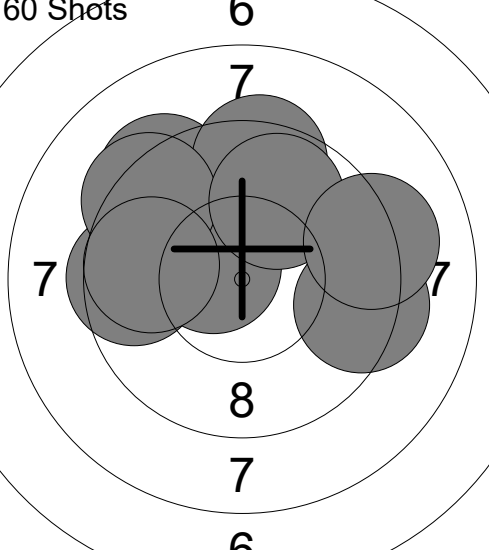
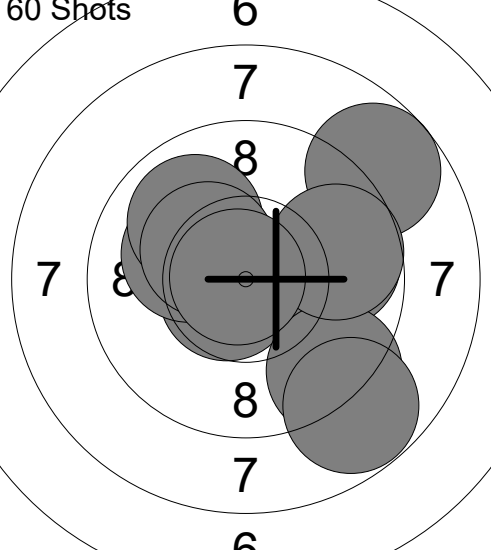
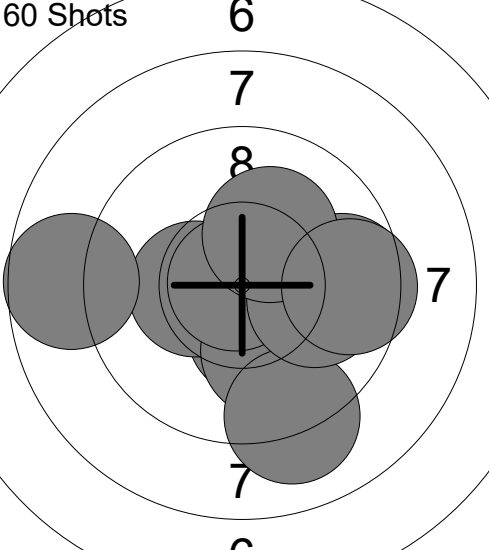
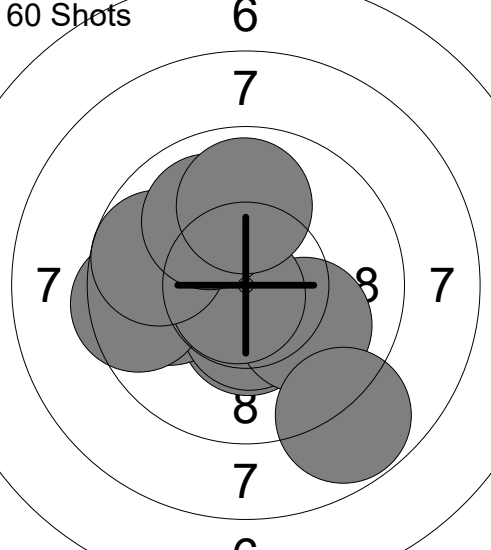
<p>60 Shots</p>  <p style="text-align: center;">6 7 8 7 7 8 7 8 7 7</p>	<p>1: 10.4x ↓ 2: 9.5 ↙ 3: 9.9 → 4: 9.9 ↖ 5: 10.7x ↑ 6: 8.8 → 7: 10.5x ↓ 8: 10.1 ← 9: 10.1 ← 10: 10.2x ↑</p> <p>Series 100.1</p>	<p>60 Shots</p>  <p style="text-align: center;">6 7 8 7 7 8 7 8 7 7</p>	<p>11: 10.4x ↓ 12: 9.2 → 13: 8.7 → 14: 10.3x → 15: 10.1 ↓ 16: 10.5x ← 17: 9.9 ↓ 18: 10.1 ↓ 19: 10.5x ↖ 20: 10.2x →</p> <p>Series 99.9</p>
100.1		200.0	
<p>60 Shots</p>  <p style="text-align: center;">6 6 7 7 7 8 7 8 7 7</p>	<p>21: 9.5 ← 22: 9.6 ↗ 23: 9.3 ↗ 24: 9.3 → 25: 10.5x ↖ 26: 9.4 ↑ 27: 9.3 ↗ 28: 9.8 ↑ 29: 9.7 ← 30: 9.2 →</p> <p>Series 95.6</p>	<p>60 Shots</p>  <p style="text-align: center;">6 6 7 7 7 8 7 8 7 7</p>	<p>31: 10.6x ↙ 32: 10.1 ↖ 33: 9.9 ↗ 34: 8.7 ↗ 35: 10.3x ↖ 36: 9.8 → 37: 9.3 ↓ 38: 9.7 → 39: 8.8 ↓ 40: 10.8x ←</p> <p>Series 98.0</p>
295.6		393.6	
<p>60 Shots</p>  <p style="text-align: center;">6 6 7 7 7 8 7 8 7 7</p>	<p>41: 10.3x ↓ 42: 10.3x ← 43: 10.0 ↓ 44: 9.1 ↓ 45: 9.6 → 46: 10.9x ↖ 47: 8.7 ← 48: 10.0 → 49: 10.2x ↗ 50: 9.5 →</p> <p>Series 98.6</p>	<p>60 Shots</p>  <p style="text-align: center;">6 6 7 7 7 8 7 8 7 7</p>	<p>51: 10.4x ↓ 52: 9.9 ← 53: 10.5x ↓ 54: 9.5 ← 55: 10.0 ↓ 56: 10.8x ↙ 57: 8.8 ↓ 58: 9.7 ← 59: 10.0 ↗ 60: 9.9 ↑</p> <p>Series 99.5</p>
492.2		591.7	

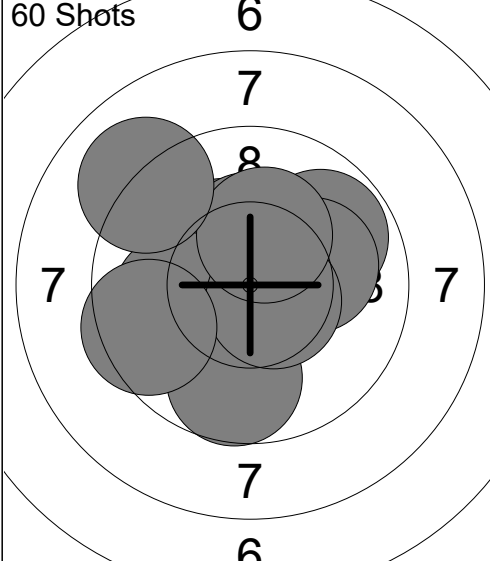
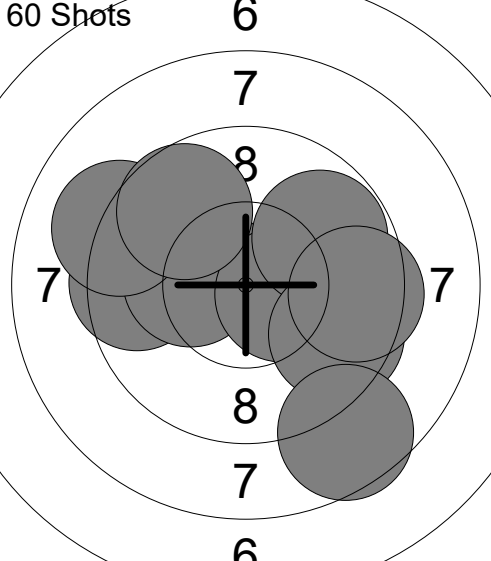
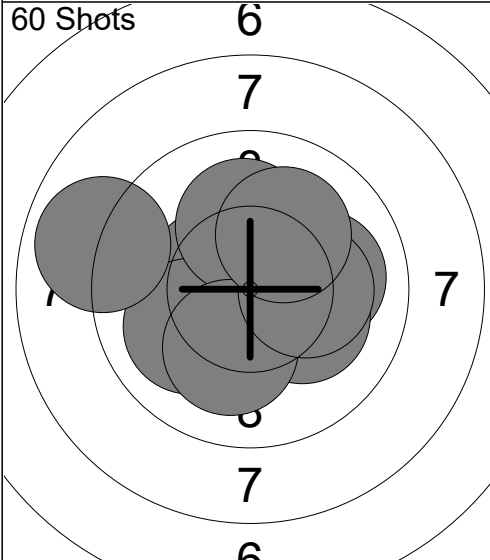
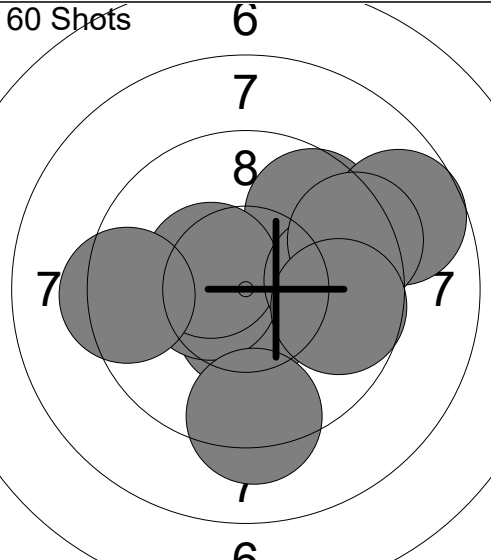
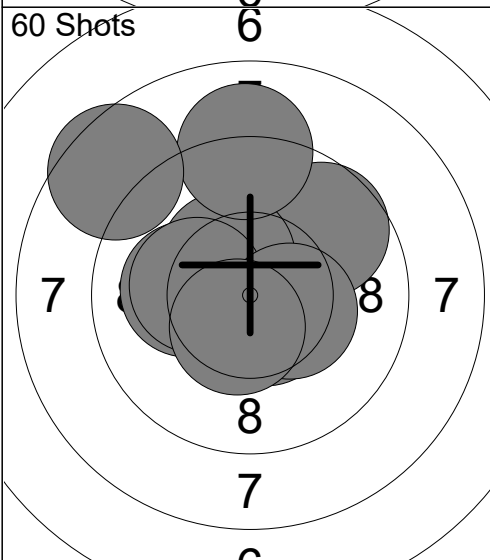
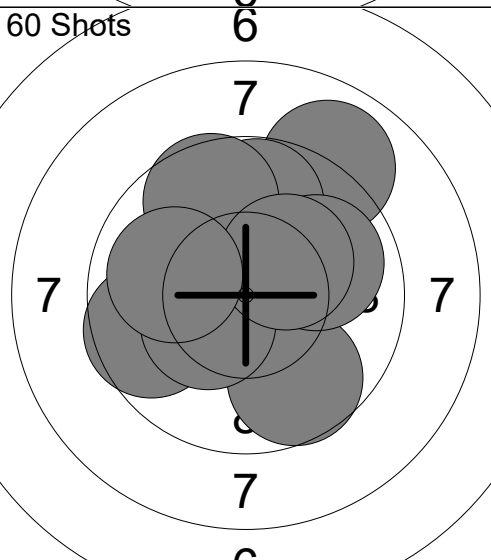
60 Shots 	1: 10.3x ↖ 2: 9.8 ↗ 3: 10.4x ↑ 4: 10.0 ← 5: 10.1 → 6: 9.7 ↓ 7: 10.6x ⇒ 8: 10.3x ↑ 9: 9.0 ↗ 10: 9.5 ← <hr/> Series 99.7 99.7	60 Shots 	11: 10.4x ↖ 12: 9.5 ← 13: 10.2x ↖ 14: 10.4x ⇒ 15: 9.8 ↗ 16: 9.6 ⇒ 17: 9.5 → 18: 9.1 ↖ 19: 8.6 ↓ 20: 9.7 ↗ <hr/> Series 96.8 196.5
60 Shots 	21: 10.0 → 22: 10.5x ↖ 23: 10.3x ⇒ 24: 10.2x ⇒ 25: 10.0 ← 26: 8.9 ← 27: 10.1 ↑ 28: 10.1 ↓ 29: 10.2x ⇒ 30: 10.1 ↗ <hr/> Series 100.4 296.9	60 Shots 	31: 9.6 ↗ 32: 10.5x ↓ 33: 10.5x ↖ 34: 10.4x ↖ 35: 9.8 → 36: 8.7 ↗ 37: 9.4 ↗ 38: 9.7 ⇒ 39: 9.3 ↓ 40: 9.4 ← <hr/> Series 97.3 394.2
60 Shots 	41: 10.1 ← 42: 10.9x ↑ 43: 10.6x ↓ 44: 9.7 ↗ 45: 10.4x ↗ 46: 10.2x ↖ 47: 9.0 ↑ 48: 10.4x ⇒ 49: 8.5 ↖ 50: 10.5x ↓ <hr/> Series 100.3 494.5	60 Shots 	51: 9.6 ← 52: 9.7 ↓ 53: 9.0 ↗ 54: 10.5x ↖ 55: 9.8 ↑ 56: 9.9 ↗ 57: 10.3x ↖ 58: 9.6 ↑ 59: 10.3x ↗ 60: 10.0 ← <hr/> Series 98.7 593.2

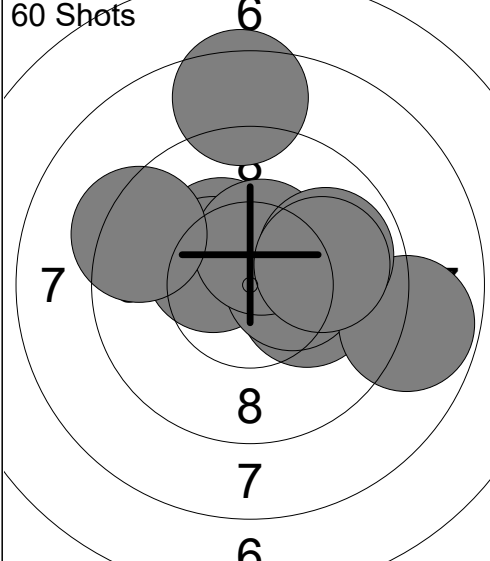
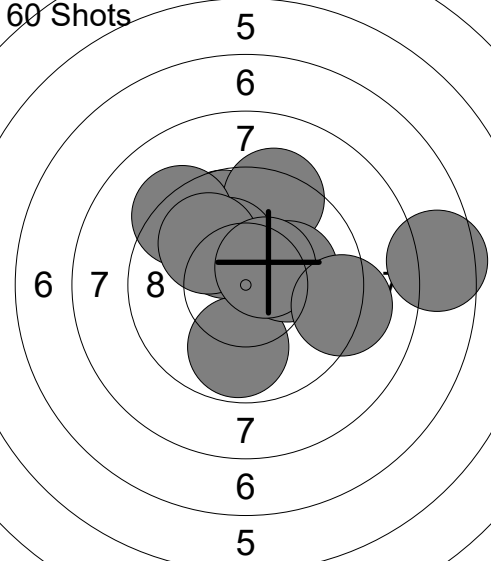
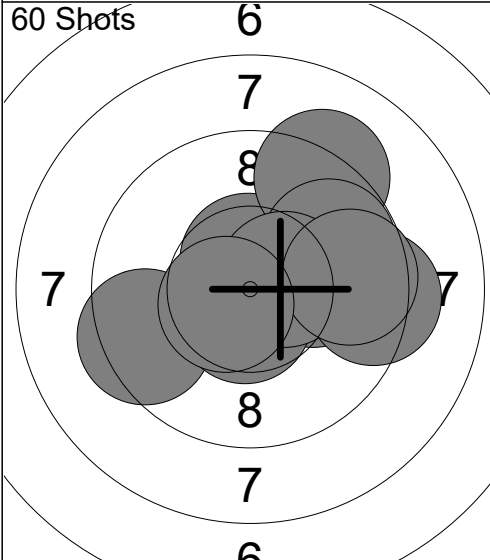
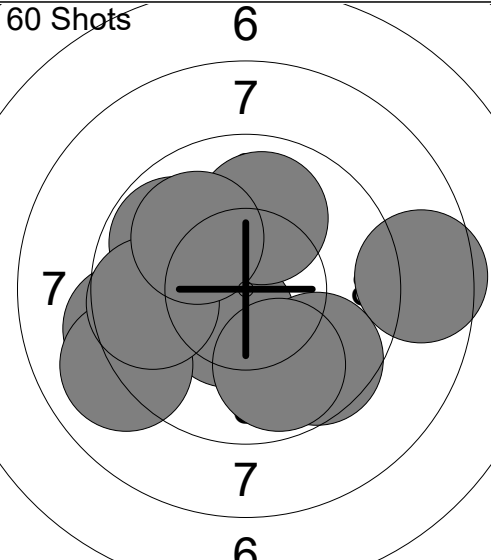
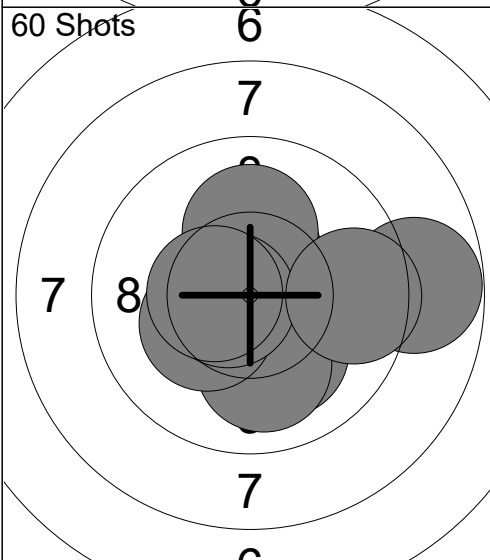
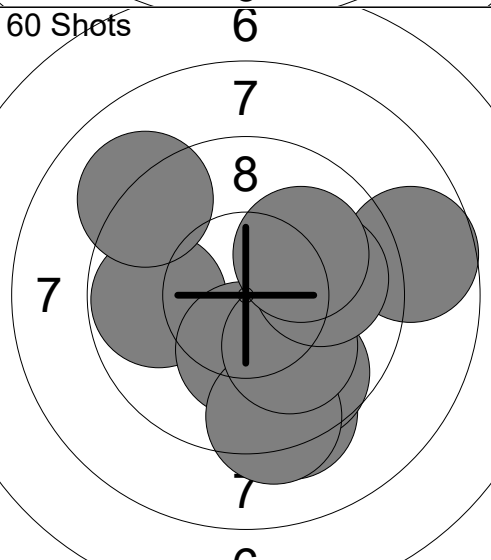
<p>60 Shots</p>  <p style="text-align: center;">6 7 8 7</p>	<p>1: 10.2x → 2: 10.3x ↖ 3: 10.4x ↙ 4: 8.5 ↑ 5: 10.4x → 6: 10.4x ↑ 7: 9.3 ↖ 8: 8.8 → 9: 9.9 → 10: 10.0 →</p> <p>Series 98.2 98.2</p>	<p>60 Shots</p>  <p style="text-align: center;">5 6 7 6 5</p>	<p>11: 7.5 → 12: 9.7 ↖ 13: 9.3 ↑ 14: 9.8 ↓ 15: 10.2x → 16: 10.2x ↖ 17: 9.3 ↖ 18: 10.0 ↖ 19: 10.5x ↗ 20: 9.2 →</p> <p>Series 95.7 193.9</p>
<p>60 Shots</p>  <p style="text-align: center;">6 7 8 7</p>	<p>21: 10.6x ↑ 22: 10.1 → 23: 9.3 → 24: 9.2 ↗ 25: 9.8 ↗ 26: 9.4 ← 27: 10.6x ↓ 28: 10.5x → 29: 9.6 → 30: 10.6x ↙</p> <p>Series 99.7 293.6</p>	<p>60 Shots</p>  <p style="text-align: center;">6 7 7</p>	<p>31: 10.5x ↓ 32: 8.6 → 33: 9.6 ↓ 34: 10.0 ↑ 35: 9.3 ← 36: 9.8 ↖ 37: 9.0 ← 38: 9.7 ← 39: 9.8 ↓ 40: 10.0 ↖</p> <p>Series 96.3 389.9</p>
<p>60 Shots</p>  <p style="text-align: center;">6 7 8 7</p>	<p>41: 10.1 ↓ 42: 10.4x ↑ 43: 10.7x ↓ 44: 10.0 ↓ 45: 10.1 ↑ 46: 10.3x ↙ 47: 8.8 → 48: 10.7x ← 49: 10.5x ← 50: 9.6 →</p> <p>Series 101.2 491.1</p>	<p>60 Shots</p>  <p style="text-align: center;">6 7 8 7</p>	<p>51: 9.3 ↓ 52: 8.7 → 53: 9.8 ← 54: 9.7 ↓ 55: 10.2x ↓ 56: 9.3 ↓ 57: 10.1 ↓ 58: 9.9 → 59: 10.0 ↗ 60: 9.1 ↖</p> <p>Series 96.1 587.2</p>

<p>60 Shots</p>	<p>60 Shots</p>	<p>Series 85.7</p> <p>Series 88.9</p> <p style="text-align: center;">174.6</p>
-----------------	-----------------	---

<p>60 Shots</p>	<p>60 Shots</p>	<p>Series 90.6</p> <p>Series 90.6</p> <p style="text-align: center;">265.2</p> <p style="text-align: center;">355.8</p>
-----------------	-----------------	---

<p>60 Shots</p>	<p>60 Shots</p>	<p>Series 87.0</p> <p>Series 93.6</p> <p style="text-align: center;">442.8</p> <p style="text-align: center;">536.4</p>
-----------------	-----------------	---

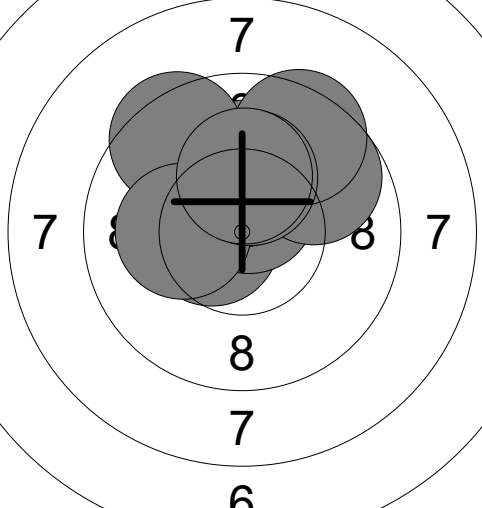
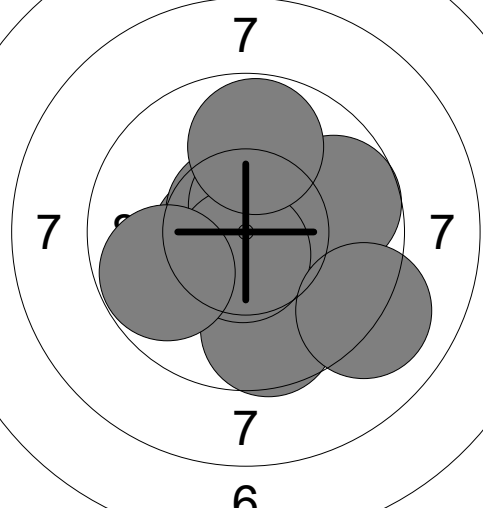
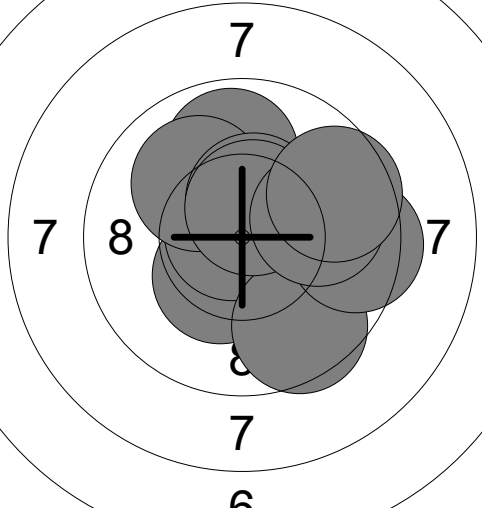
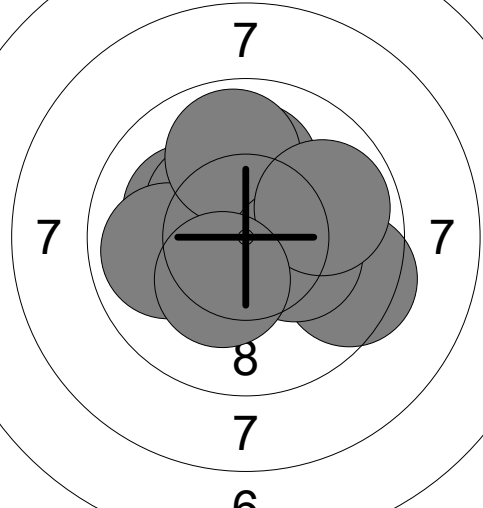
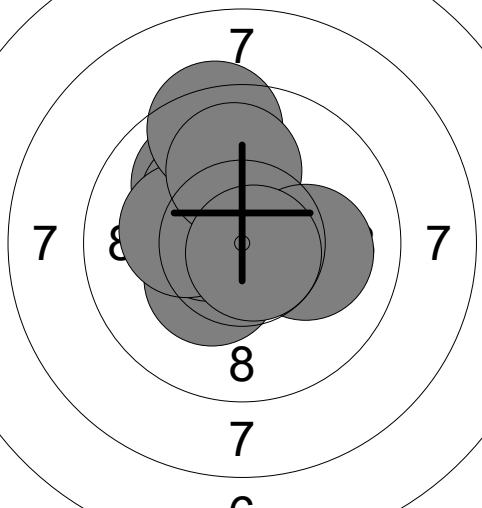
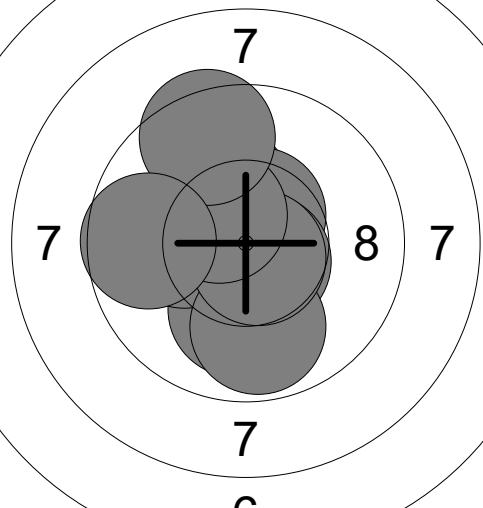
<p>60 Shots</p> <p style="text-align: center;">6</p> 	<p>1: 10.5x ←</p> <p>2: 10.6x ↑</p> <p>3: 10.2x ↑</p> <p>4: 10.1 ↑</p> <p>5: 9.8 ↗</p> <p>6: 9.5 ↗</p> <p>7: 9.5 ↖</p> <p>8: 10.2x ←</p> <p>9: 10.2x ↑</p> <p>10: 10.2x ↑</p> <hr/> <p>Series 100.8</p> <hr/> <p style="text-align: center;">100.8</p>	<p>60 Shots</p> <p style="text-align: center;">6</p> 	<p>11: 10.6x ←</p> <p>12: 10.3x ↗</p> <p>13: 10.7x ↖</p> <p>14: 10.6x ↑</p> <p>15: 9.6 ↓</p> <p>16: 9.7 →</p> <p>17: 10.6x ↓</p> <p>18: 9.8 ←</p> <p>19: 9.8 ↑</p> <p>20: 9.1 ↘</p> <hr/> <p>Series 100.8</p> <hr/> <p style="text-align: center;">201.6</p>
<p>60 Shots</p> <p style="text-align: center;">6</p> 	<p>21: 10.4x ↓</p> <p>22: 10.8x ←</p> <p>23: 9.6 ↓</p> <p>24: 9.9 ↑</p> <p>25: 9.4 →</p> <p>26: 10.0 ↗</p> <p>27: 10.4x ↑</p> <p>28: 10.5x ↑</p> <p>29: 9.9 →</p> <p>30: 9.6 →</p> <hr/> <p>Series 100.5</p> <hr/> <p style="text-align: center;">302.1</p>	<p>60 Shots</p> <p style="text-align: center;">6</p> 	<p>31: 9.5 ⇒</p> <p>32: 10.1 ←</p> <p>33: 10.1 ↑</p> <p>34: 10.4x ↖</p> <p>35: 10.6x ←</p> <p>36: 9.9 ←</p> <p>37: 9.9 ↑</p> <p>38: 10.3x ⇒</p> <p>39: 9.9 →</p> <p>40: 10.3x ↓</p> <hr/> <p>Series 101.0</p> <hr/> <p style="text-align: center;">403.1</p>
<p>60 Shots</p> <p style="text-align: center;">6</p> 	<p>41: 10.1 ↖</p> <p>42: 10.0 ↖</p> <p>43: 10.3x ↙</p> <p>44: 10.2x ↖</p> <p>45: 10.5x ←</p> <p>46: 10.2x ←</p> <p>47: 9.4 ↑</p> <p>48: 10.0 ↑</p> <p>49: 10.1 →</p> <p>50: 10.8x ↘</p> <hr/> <p>Series 101.6</p> <hr/> <p style="text-align: center;">504.7</p>	<p>60 Shots</p> <p style="text-align: center;">6</p> 	<p>51: 10.1 ↓</p> <p>52: 10.2x ↖</p> <p>53: 10.1 ←</p> <p>54: 10.6x ↑</p> <p>55: 10.6x ↘</p> <p>56: 9.8 ↓</p> <p>57: 10.7x ↘</p> <p>58: 10.4x ↗</p> <p>59: 9.5 ↑</p> <p>60: 9.7 ←</p> <hr/> <p>Series 101.7</p> <hr/> <p style="text-align: center;">606.4</p>

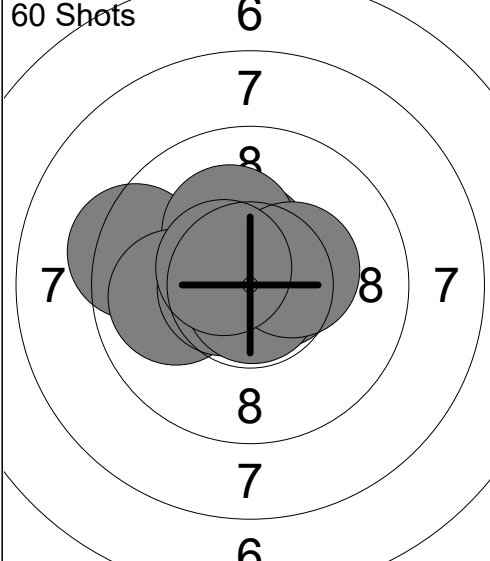
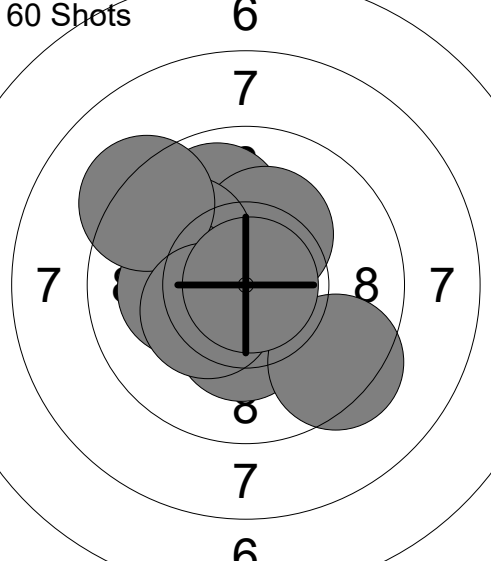
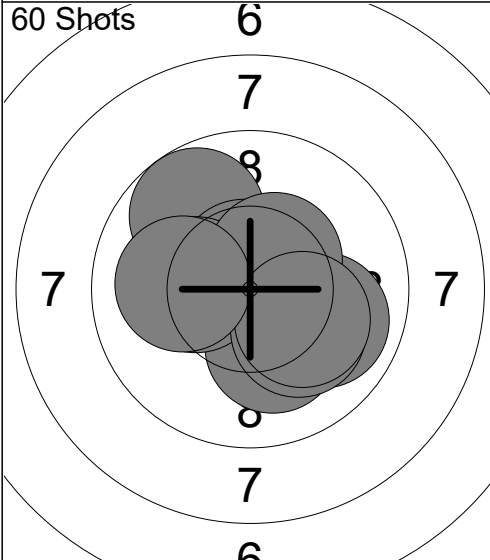
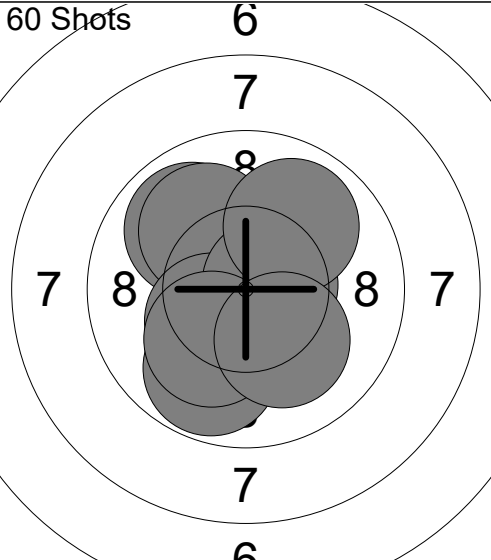
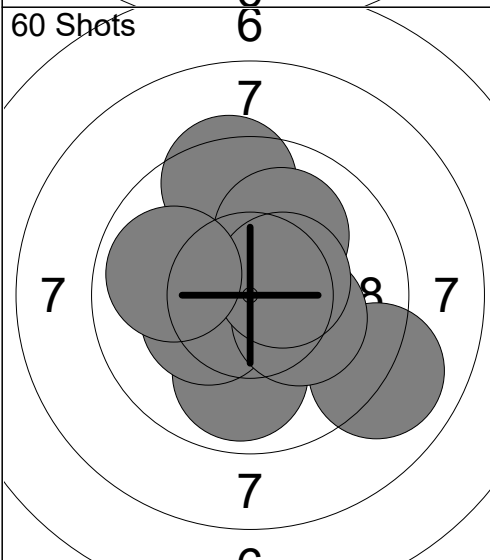
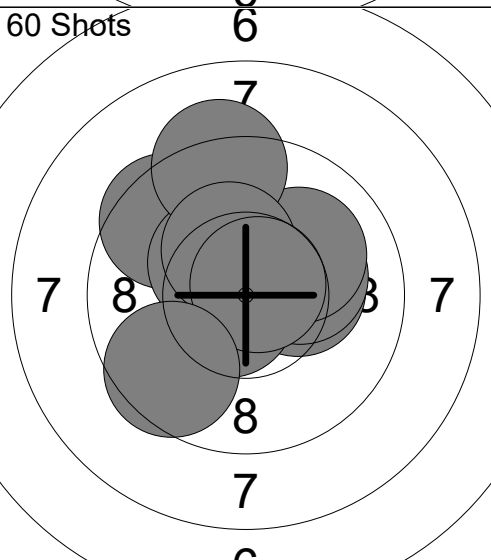
60 Shots 	1: 9.4 ← 2: 10.6x → 3: 10.4x ↑ 4: 10.5x ↑ 5: 10.2x ↑ 6: 9.9 ← 7: 10.6x ← 8: 10.8x ↓ 9: 10.4x → 10: 10.5x ↖ <hr/> Series 103.3 103.3	60 Shots 	11: 9.9 ↑ 12: 10.7x ↖ 13: 10.2x ↑ 14: 10.0 ↖ 15: 10.3x ↓ 16: 10.1 ← 17: 9.4 ↘ 18: 9.2 ↖ 19: 10.3x ↖ 20: 10.9x → <hr/> Series 101.0 204.3
60 Shots 	21: 9.9 → 22: 10.2x ↓ 23: 10.6x ↗ 24: 9.8 ↗ 25: 10.6x ↑ 26: 10.2x ← 27: 10.1 ↘ 28: 10.5x ↗ 29: 10.1 ↘ 30: 10.1 ← <hr/> Series 102.1 306.4	60 Shots 	31: 9.8 ↓ 32: 9.9 ↖ 33: 10.8x ↑ 34: 10.6x ↖ 35: 10.0 ↖ 36: 10.3x ↖ 37: 10.6x → 38: 9.9 ↗ 39: 10.1 ↓ 40: 10.1 ↘ <hr/> Series 102.1 408.5
60 Shots 	41: 10.5x ↑ 42: 9.9 ↓ 43: 10.5x → 44: 9.4 ↑ 45: 10.3x ↖ 46: 10.1 ↗ 47: 9.0 ↘ 48: 10.2x → 49: 10.5x → 50: 9.9 ← <hr/> Series 100.3 508.8	60 Shots 	51: 10.3x → 52: 10.2x → 53: 10.6x ↖ 54: 10.1 ↗ 55: 9.5 ↖ 56: 10.4x ↖ 57: 9.2 ↑ 58: 10.3x ↑ 59: 10.7x ↗ 60: 9.6 ↖ <hr/> Series 100.9 609.7

<p>60 Shots</p>	<p>1: 9.8 ↓ 2: 10.2x ↙ 3: 9.9 ↓ 4: 9.2 ← 5: 9.4 ↓ 6: 10.0 ← 7: 9.7 ↗ 8: 9.4 ↗ 9: 8.4 ← 10: 10.1 ↓</p> <p>Series 96.1 96.1</p>	<p>60 Shots</p>	<p>11: 10.6x ↗ 12: 10.8x ↗ 13: 9.3 ← 14: 9.2 ↗ 15: 9.9 ↗ 16: 10.0 ↗ 17: 10.1 ↓ 18: 9.9 ↗ 19: 10.0 ↑ 20: 10.7x →</p> <p>Series 100.5 196.6</p>
<p>60 Shots</p>	<p>21: 9.2 ↓ 22: 10.4x → 23: 9.7 ↗ 24: 9.8 ↗ 25: 8.7 ← 26: 9.8 ↗ 27: 9.9 → 28: 10.7x ↙ 29: 10.4x ↗ 30: 10.7x ↓</p> <p>Series 99.3 295.9</p>	<p>60 Shots</p>	<p>31: 10.7x ↓ 32: 10.4x ↑ 33: 10.7x → 34: 10.2x ↓ 35: 10.4x ↓ 36: 9.0 ↑ 37: 10.4x ↗ 38: 9.2 ← 39: 10.5x ← 40: 10.4x ←</p> <p>Series 101.9 397.8</p>
<p>60 Shots</p>	<p>41: 9.1 ↓ 42: 10.1 → 43: 10.1 → 44: 10.8x → 45: 10.4x ↑ 46: 10.4x ↑ 47: 10.6x ↙ 48: 10.8x ↗ 49: 10.3x ↗ 50: 9.7 ←</p> <p>Series 102.3 500.1</p>	<p>60 Shots</p>	<p>51: 10.2x ↙ 52: 10.0 → 53: 9.8 → 54: 10.1 ↗ 55: 9.7 ← 56: 9.8 ↗ 57: 10.5x ↙ 58: 9.7 ↗ 59: 10.5x → 60: 8.5 →</p> <p>Series 98.8 598.9</p>

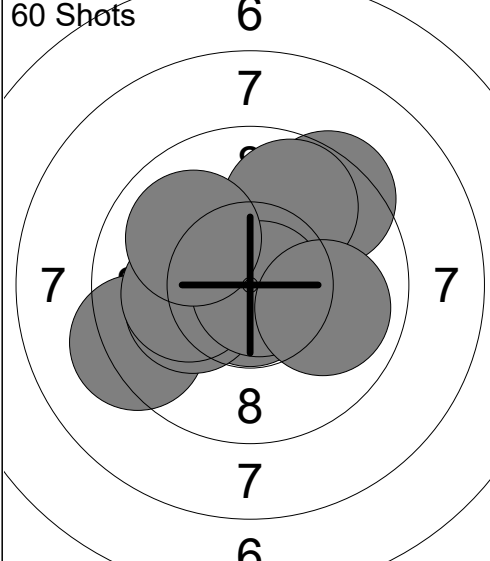
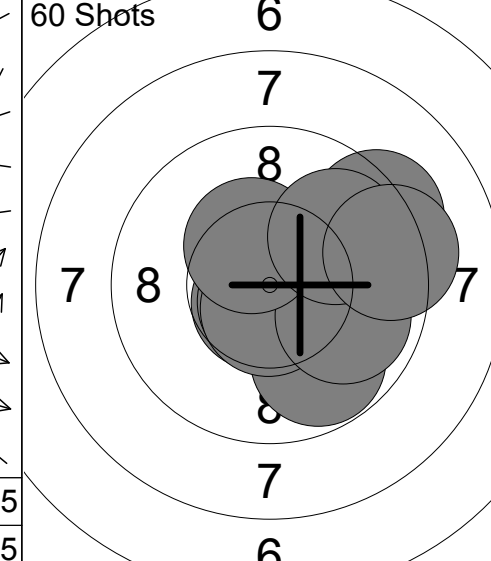
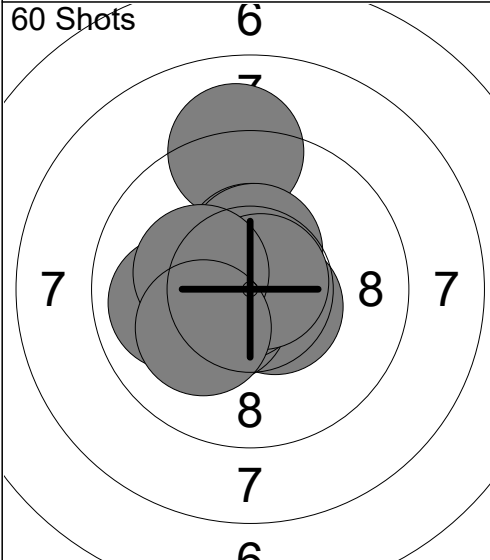
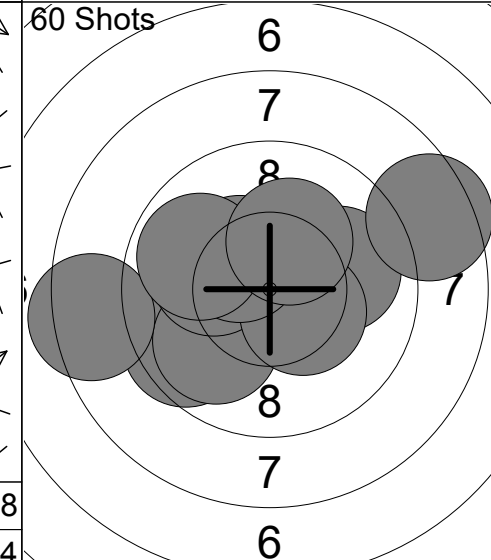
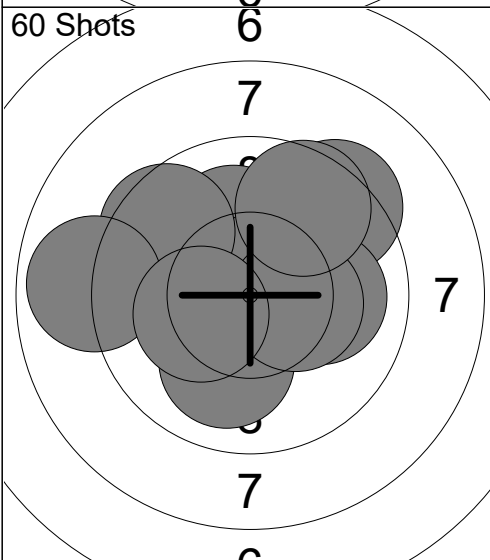
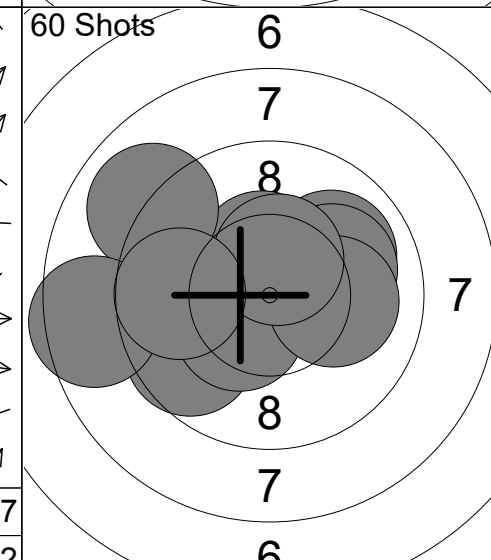
<p>60 Shots</p>  <p style="text-align: center;">6 7 7 8 7 7 7 8 7 7</p>	<p>1: 9.3 ←</p> <p>2: 10.8x ↓</p> <p>3: 10.1 ←</p> <p>4: 10.3x ←</p> <p>5: 10.1 ←</p> <p>6: 9.4 ↗</p> <p>7: 9.8 ↗</p> <p>8: 10.8x →</p> <p>9: 9.9 →</p> <p>10: 10.0 ↖</p> <hr/> <p>Series 100.5</p>	<p>60 Shots</p>  <p style="text-align: center;">6 7 7 8 7 7 7 8 7 7</p>	<p>11: 10.7x ↓</p> <p>12: 10.5x ↑</p> <p>13: 10.7x ↓</p> <p>14: 9.8 ↓</p> <p>15: 10.6x ↓</p> <p>16: 9.9 →</p> <p>17: 10.4x ↑</p> <p>18: 9.3 ↗</p> <p>19: 9.9 ↗</p> <p>20: 9.3 →</p> <hr/> <p>Series 101.1</p>
100.5		201.6	
<p>60 Shots</p>  <p style="text-align: center;">6 7 7 8 7 7 7 8 7 7</p>	<p>21: 10.5x →</p> <p>22: 9.1 ↑</p> <p>23: 10.4x ↓</p> <p>24: 10.0 ←</p> <p>25: 10.4x ↑</p> <p>26: 10.8x ←</p> <p>27: 10.4x ↑</p> <p>28: 10.8x ↗</p> <p>29: 10.3x ←</p> <p>30: 10.1 ↓</p> <hr/> <p>Series 102.8</p>	<p>60 Shots</p>  <p style="text-align: center;">6 7 7 8 7 7 7 8 7 7</p>	<p>31: 9.9 →</p> <p>32: 9.5 ←</p> <p>33: 9.9 ↓</p> <p>34: 10.1 ←</p> <p>35: 10.4x →</p> <p>36: 10.3x ↖</p> <p>37: 8.4 ←</p> <p>38: 8.5 →</p> <p>39: 9.9 ←</p> <p>40: 10.2x ↑</p> <hr/> <p>Series 97.1</p>
304.4		401.5	
<p>60 Shots</p>  <p style="text-align: center;">6 7 7 8 7 7 7 8 7 7</p>	<p>41: 10.1 ↑</p> <p>42: 9.3 ↗</p> <p>43: 10.6x ↗</p> <p>44: 9.6 ↖</p> <p>45: 8.9 ←</p> <p>46: 10.0 ↓</p> <p>47: 10.0 →</p> <p>48: 10.3x →</p> <p>49: 10.3x ←</p> <p>50: 9.6 ↗</p> <hr/> <p>Series 98.7</p>	<p>60 Shots</p>  <p style="text-align: center;">6 7 7 8 7 7 7 8 7 7</p>	<p>51: 9.6 ↓</p> <p>52: 10.4x ↑</p> <p>53: 9.0 ↖</p> <p>54: 10.0 ↗</p> <p>55: 10.4x ↓</p> <p>56: 10.0 →</p> <p>57: 10.1 →</p> <p>58: 8.5 ←</p> <p>59: 10.5x ↑</p> <p>60: 9.7 ←</p> <hr/> <p>Series 98.2</p>
500.2		598.4	

<p>60 Shots</p> <p style="text-align: center;">6 7 8 7</p>	<p>1: 9.5 ➤</p> <p>2: 9.5 ↗</p> <p>3: 9.8 ←</p> <p>4: 10.5x ↑</p> <p>5: 10.4x ↓</p> <p>6: 9.9 ↙</p> <p>7: 10.8x ↘</p> <p>8: 10.3x ↘</p> <p>9: 10.1 ←</p> <p>10: 9.1 ←</p> <hr/> <p>Series 99.9</p> <hr/> <p style="text-align: center;">99.9</p>	<p>60 Shots</p> <p style="text-align: center;">5 6 7 8 7 6</p>	<p>11: 10.2x ←</p> <p>12: 9.8 ↓</p> <p>13: 8.8 ←</p> <p>14: 8.2 ↗</p> <p>15: 9.5 ←</p> <p>16: 7.6 ←</p> <p>17: 8.5 ←</p> <p>18: 8.2 ➤</p> <p>19: 10.7x ↘</p> <p>20: 9.3 ←</p> <hr/> <p>Series 90.8</p> <hr/> <p style="text-align: center;">190.7</p>
--	--	--	---

<p>60 Shots</p> <p style="text-align: center;">6 3 4 5 6 7 8 7 6 5 4 3</p>	<p>21: 9.4 ➤</p> <p>22: 9.0 ↗</p> <p>23: 8.9 ↓</p> <p>24: 9.3 ↗</p> <p>25: 7.9 ←</p> <p>26: 9.2 ↘</p> <p>27: 9.8 ↓</p> <p>28: 5.9 ←</p> <p>29: 10.5x ↘</p> <p>30: 9.3 ↗</p> <hr/> <p>Series 89.2</p> <hr/> <p style="text-align: center;">279.9</p>	<p>60 Shots</p> <p style="text-align: center;">5 6 7 8 7 6</p>	<p>31: 10.4x ←</p> <p>32: 9.0 ↓</p> <p>33: 7.8 ↑</p> <p>34: 9.4 ↓</p> <p>35: 10.4x ➤</p> <p>36: 8.2 ➤</p> <p>37: 10.2x ←</p> <p>38: 9.7 ↗</p> <p>39: 7.5 ←</p> <p>40: 9.2 ↗</p> <hr/> <p>Series 91.8</p> <hr/> <p style="text-align: center;">371.7</p>
--	---	--	---

<p>60 Shots</p> <p style="text-align: center;">3 4 5 6 7 8 7 6 5 4 3</p>	<p>41: 8.5 ←</p> <p>42: 9.6 ↗</p> <p>43: 8.6 ←</p> <p>44: 8.8 ↗</p> <p>45: 8.8 ↗</p> <p>46: 10.1 ➤</p> <p>47: 9.4 ↗</p> <p>48: 9.6 ➤</p> <p>49: 7.0 ↗</p> <p>50: 5.7 ←</p> <hr/> <p>Series 86.1</p> <hr/> <p style="text-align: center;">457.8</p>	<p>60 Shots</p> <p style="text-align: center;">5 6 7 8 7 6</p>	<p>51: 7.5 ←</p> <p>52: 9.3 ↗</p> <p>53: 8.0 ←</p> <p>54: 8.9 ↗</p> <p>55: 10.2x ↗</p> <p>56: 9.0 ↓</p> <p>57: 9.6 ←</p> <p>58: 9.3 ↑</p> <p>59: 9.4 ➤</p> <p>60: 9.5 ↓</p> <hr/> <p>Series 90.7</p> <hr/> <p style="text-align: center;">548.5</p>
--	--	--	---

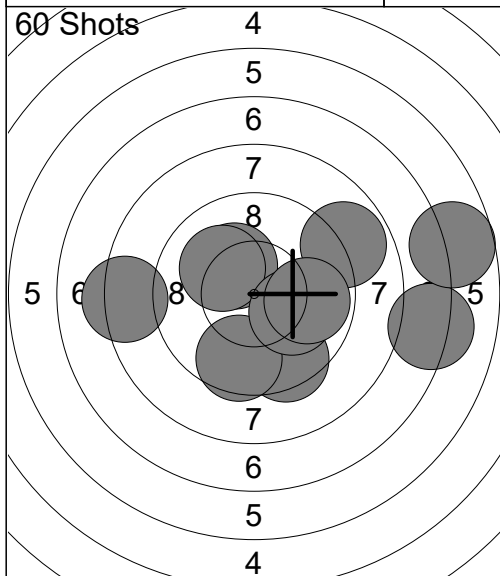

1:	10.2x ↗
2:	10.1 ↗
3:	9.4 ↓
4:	7.2 →
5:	9.6 ↓
6:	8.3 ←
7:	6.7 →
8:	10.1 →
9:	8.8 →
10:	9.8 →
Series	90.2
	90.2

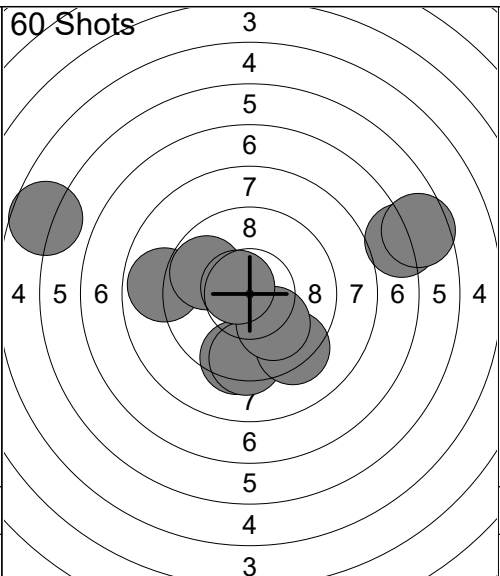

11:	8.9 ←
12:	7.0 →
13:	5.7 ←
14:	9.4 ↓
15:	9.4 ↓
16:	6.6 →
17:	9.3 ↓
18:	9.8 ↖
19:	10.0 ↓
20:	10.6x ↖
Series	86.7
	176.9

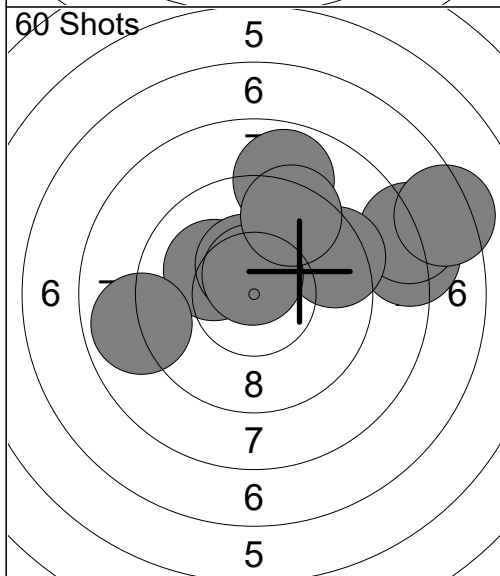

21:	10.1 ↖
22:	8.1 →
23:	8.0 →
24:	8.9 ←
25:	10.4x ↑
26:	9.4 →
27:	10.6x ↑
28:	8.9 ↑
29:	9.4 ↑
30:	7.3 →
Series	91.1
	268.0

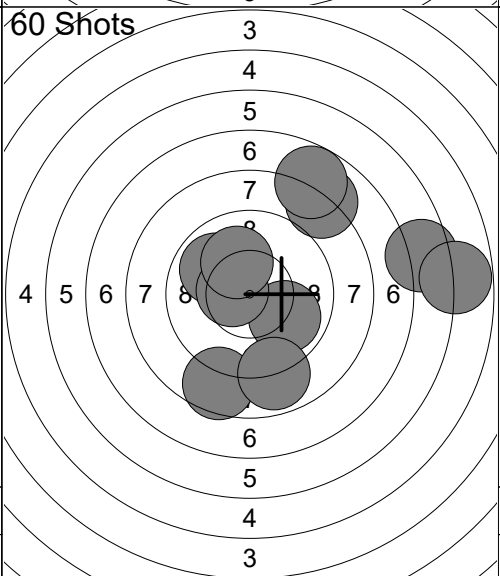

31:	8.0 ↗
32:	9.9 →
33:	6.6 →
34:	9.9 ↖
35:	10.5x ←
36:	8.6 ↓
37:	8.9 ↓
38:	5.8 →
39:	10.1 ↑
40:	7.8 ↗
Series	86.1
	354.1

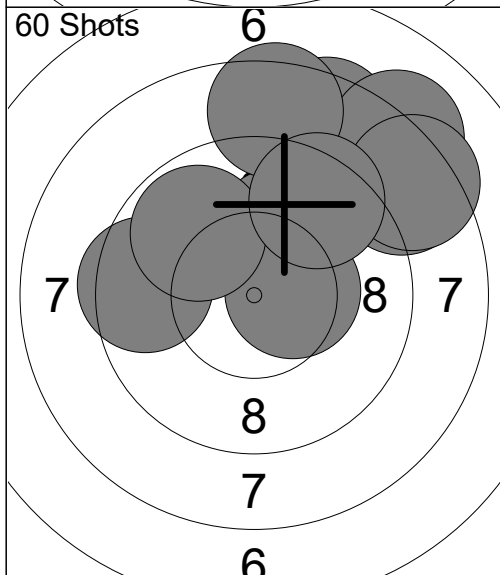

41:	10.1 ↑
42:	10.4x →
43:	8.5 ↗
44:	8.5 ↑
45:	9.5 ←
46:	8.1 ↗
47:	8.5 ↑
48:	8.4 ↗
49:	9.8 ↖
50:	9.4 ↗
Series	91.2
	445.3

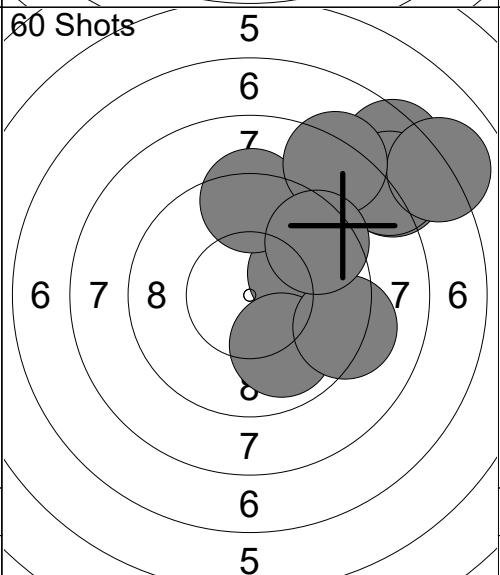

51:	10.0 →
52:	9.3 ↑
53:	7.5 ↗
54:	7.8 ↗
55:	7.9 ↗
56:	7.0 ↗
57:	9.9 ↓
58:	9.2 →
59:	8.2 ↗
60:	9.5 ↗
Series	86.3
	531.6

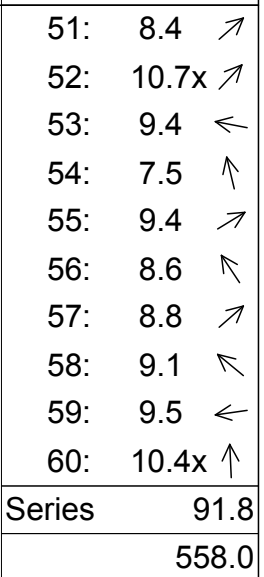
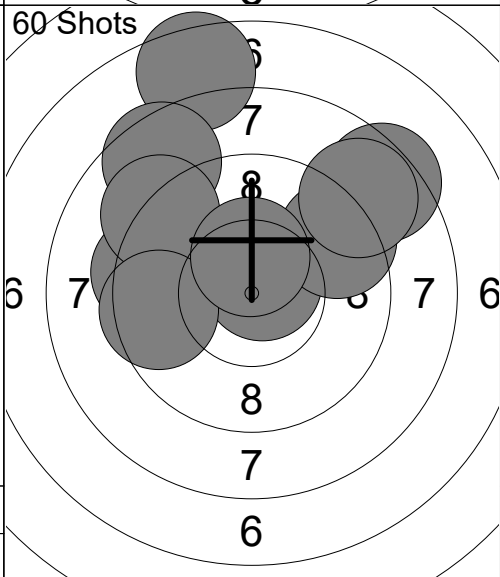
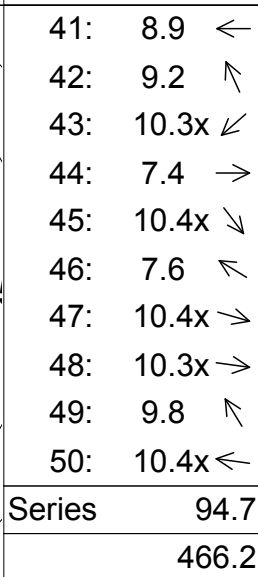
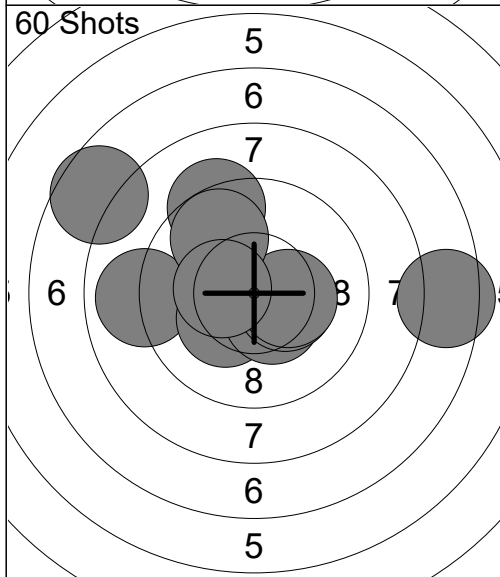
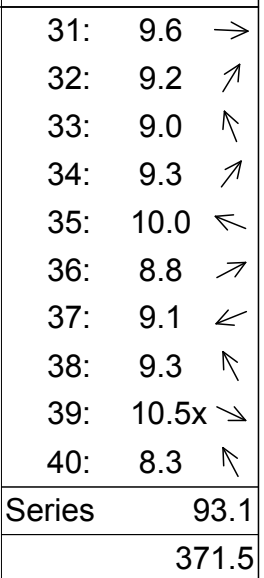
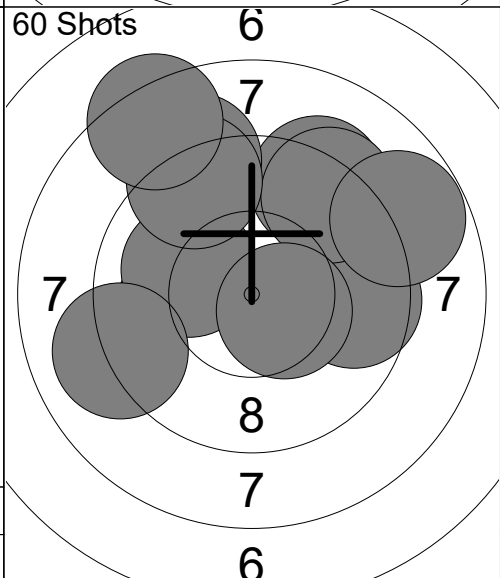
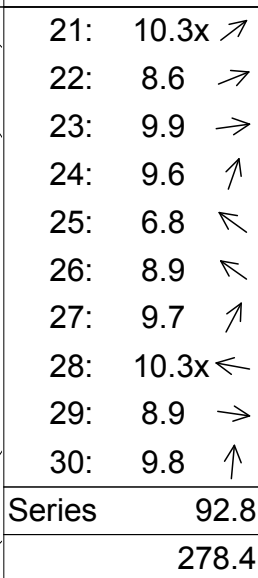
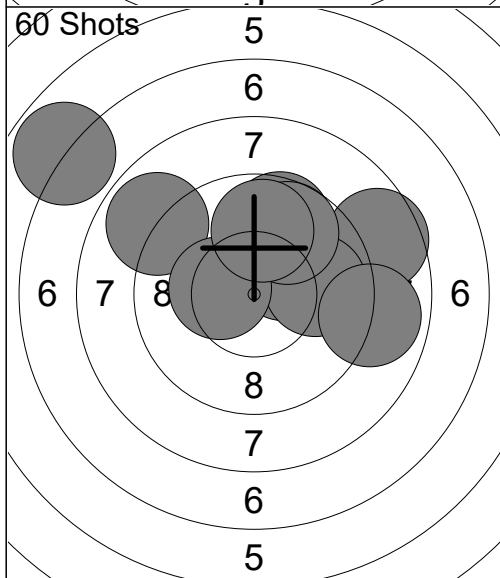
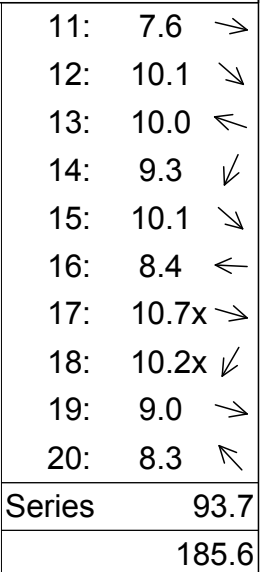
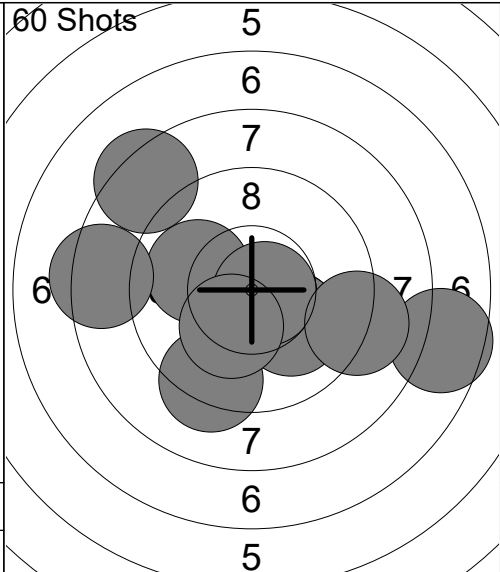
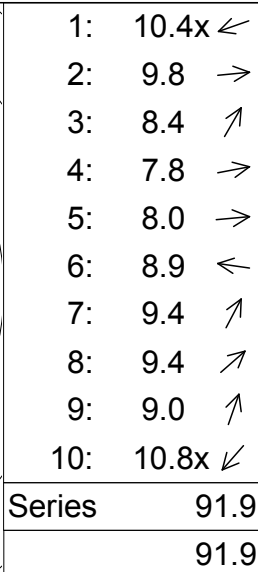
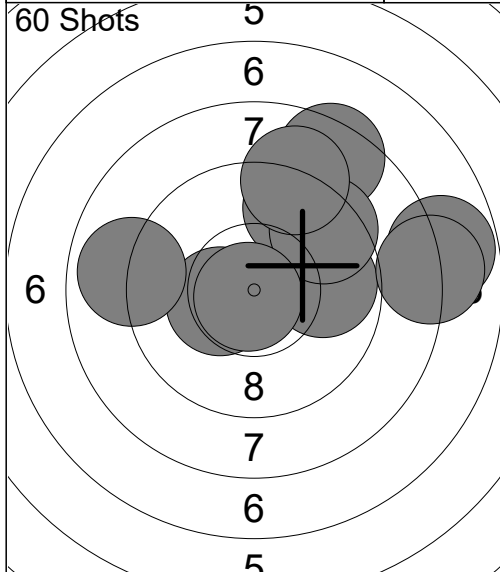

Relay 3	Lane 33	ABBATE Matteo
--------------------------	--------------------------	----------------------

1-80	St. Louis University HS White	Precision
------	-------------------------------	-----------

31.01.2025	2025 AirNats by X Count	Civilian Marksmanship Program
------------	-------------------------	-------------------------------

Comment	Signature
---------	-----------

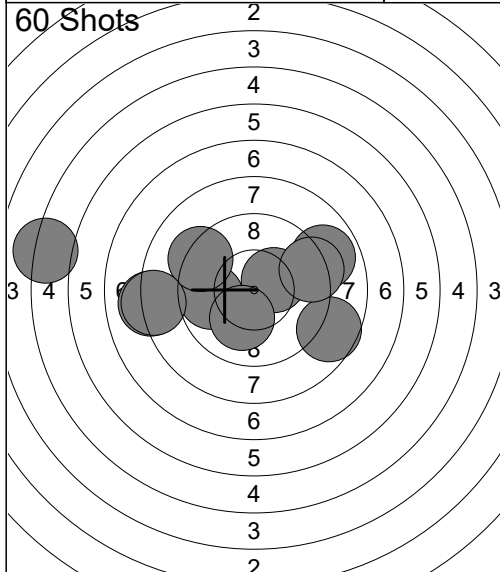

1: 9.8 ←
2: 8.6 →
3: 8.1 ←
4: 9.3 ↖
5: 10.3x →
6: 8.2 ←
7: 5.1 ←
8: 10.1 ↓
9: 8.9 →
10: 9.3 →
Series 87.7

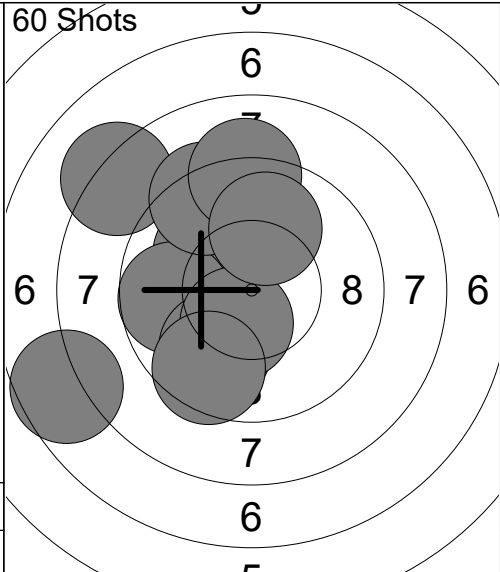

11: 10.1 ↖
12: 9.7 ←
13: 8.2 ↖
14: 9.9 ↓
15: 9.3 ↖
16: 7.6 ←
17: 10.4x ↓
18: 9.1 ↑
19: 9.5 ↓
20: 10.0 ↑
Series 93.8

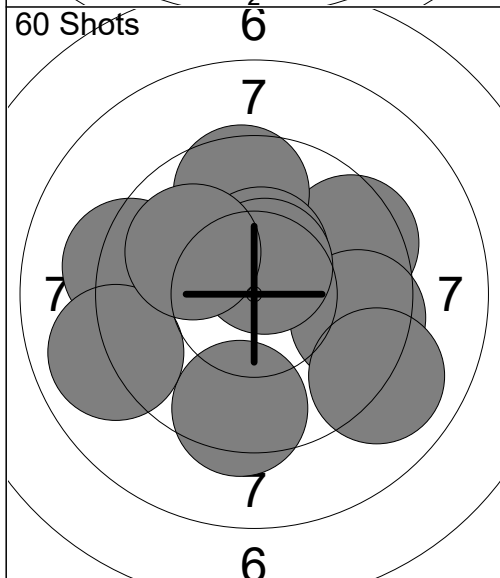

21: 9.5 →
22: 9.4 ↓
23: 9.3 ←
24: 9.5 →
25: 9.6 ↑
26: 10.4x ↑
27: 10.6x ↑
28: 9.0 →
29: 9.0 ←
30: 10.0 ↖
Series 96.3

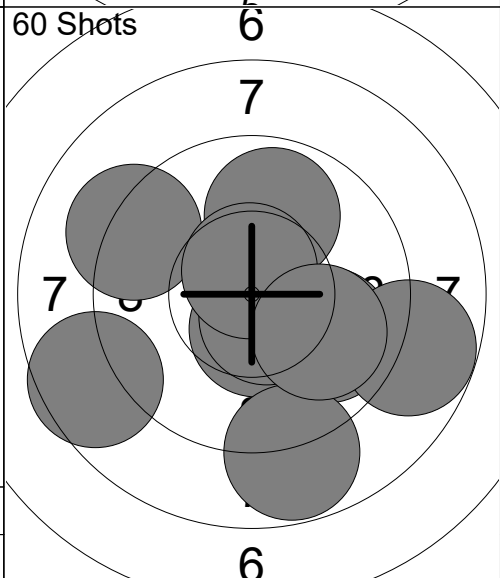

31: 9.8 →
32: 9.9 ↑
33: 10.5x ↓
34: 8.8 ↓
35: 9.2 ↖
36: 10.6x ↓
37: 8.8 →
38: 10.6x ↑
39: 9.9 →
40: 8.6 ←
Series 96.7

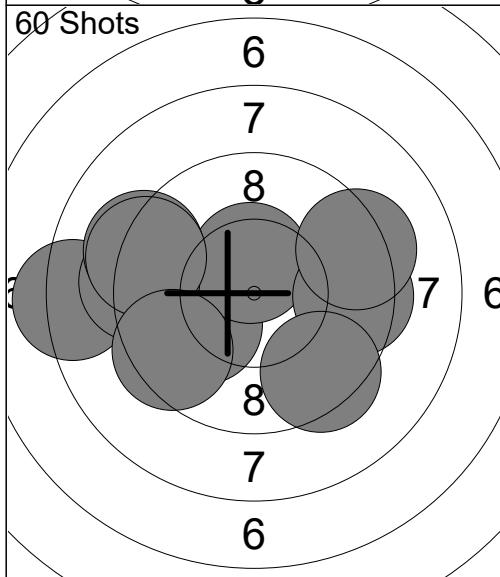

41: 10.0 ←
42: 8.2 ←
43: 10.5x ↑
44: 9.5 →
45: 9.3 →
46: 9.2 ←
47: 9.2 ↖
48: 9.3 ↖
49: 9.5 ↖
50: 9.4 ↓
Series 94.1

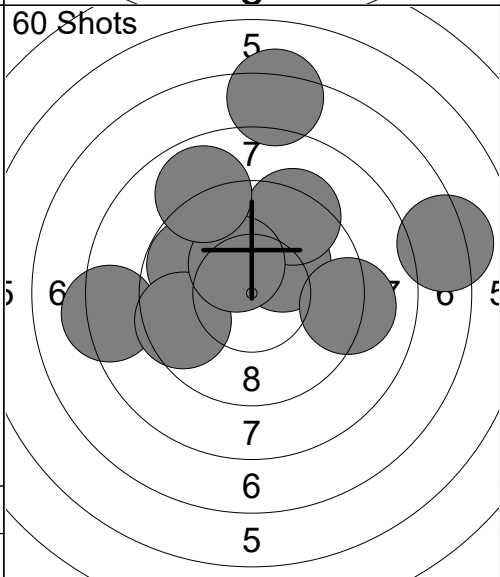

51: 10.2x ↗
52: 9.3 ↖
53: 8.3 ←
54: 9.1 →
55: 9.8 ↖
56: 9.6 ←
57: 10.3x ↖
58: 7.3 ↑
59: 7.2 →
60: 8.9 ↖
Series 90.0

<p>60 Shots</p>	<p>1: 8.1 ↓ 2: 9.7 ↑ 3: 9.4 ↓ 4: 10.5x ↓ 5: 6.6 → 6: 9.5 → 7: 8.1 → 8: 9.3 ↓ 9: 9.4 ↑ 10: 10.2x ↓</p> <p>Series 90.8</p>	<p>60 Shots</p>
	90.8	179.5

<p>60 Shots</p>	<p>21: 9.8 ← 22: 10.4x ↗ 23: 9.6 ↓ 24: 10.0 ↓ 25: 9.2 ↗ 26: 9.3 → 27: 9.7 ← 28: 10.7x ← 29: 8.9 ↖ 30: 8.8 →</p> <p>Series 96.4</p>	<p>60 Shots</p>
	275.9	366.5

<p>60 Shots</p>	<p>41: 10.1 ↓ 42: 8.5 ← 43: 8.9 ↑ 44: 8.0 → 45: 7.1 ↑ 46: 9.9 ↗ 47: 10.2x ↓ 48: 9.4 ← 49: 9.8 ↗ 50: 9.3 ←</p> <p>Series 91.2</p>	<p>60 Shots</p>
	457.7	537.8

<p>60 Shots</p> <p>3 4 5 6 7 8 4 5 6 7 8 8 7 6 5 4 7 6 5 4 3</p> <p>1: 10.3x ← 2: 10.0 ↓ 3: 5.7 ← 4: 6.9 ← 5: 9.2 ↓ 6: 8.7 → 7: 9.4 ↓ 8: 10.2x ↓ 9: 9.6 ↓ 10: 9.9 ↓</p> <p>Series 89.9 89.9</p>	<p>60 Shots</p> <p>6 7 7 8 7 8 7 8 7 7</p> <p>11: 9.7 ← 12: 8.3 → 13: 9.6 ↗ 14: 10.5x → 15: 8.4 ↗ 16: 8.7 → 17: 7.7 ↗ 18: 10.6x ↗ 19: 8.5 → 20: 9.7 ↑</p> <p>Series 91.7 181.6</p>
---	--

<p>60 Shots</p> <p>4 5 6 7 8 5 6 7 6 5 8 7 6 5 4</p> <p>21: 6.9 ← 22: 9.1 ← 23: 10.4x ← 24: 8.2 ← 25: 10.4x ← 26: 10.2x ↑ 27: 8.8 → 28: 10.4x → 29: 9.3 ↑ 30: 8.3 ←</p> <p>Series 92.0 273.6</p>	<p>60 Shots</p> <p>3 4 5 6 7 6 7 8 7 6 5 4 3 4 3</p> <p>31: 10.0 → 32: 5.9 ← 33: 9.3 → 34: 9.3 ↑ 35: 8.7 ← 36: 10.2x ↑ 37: 8.2 ← 38: 9.9 ↗ 39: 9.4 ↖ 40: 10.5x ↓</p> <p>Series 91.4 365.0</p>
--	---

<p>60 Shots</p> <p>6 6 8 8 7 6 8 7 6 6</p> <p>41: 8.9 ↑ 42: 9.7 ↗ 43: 9.8 ↗ 44: 9.6 → 45: 8.1 → 46: 9.9 ↓ 47: 10.4x ↓ 48: 8.6 → 49: 10.5x ↖ 50: 8.3 ←</p> <p>Series 93.8 458.8</p>	<p>60 Shots</p> <p>5 6 7 8 7 6 5 7 6 5 7 6 5 4</p> <p>51: 10.5x → 52: 9.0 ↑ 53: 9.6 → 54: 8.4 ↖ 55: 10.6x ↓ 56: 10.7x → 57: 7.0 ← 58: 10.2x ← 59: 9.9 ← 60: 9.0 ←</p> <p>Series 94.9 553.7</p>
--	--

Relay 3	Lane 36	MEINEN Olive
-------------------	-------------------	---------------------

1-80	Minnesota Center Shots	Precision	
31.01.2025	2025 AirNats by X Count	Civilian Marksmanship Program	
Comment	Signature		

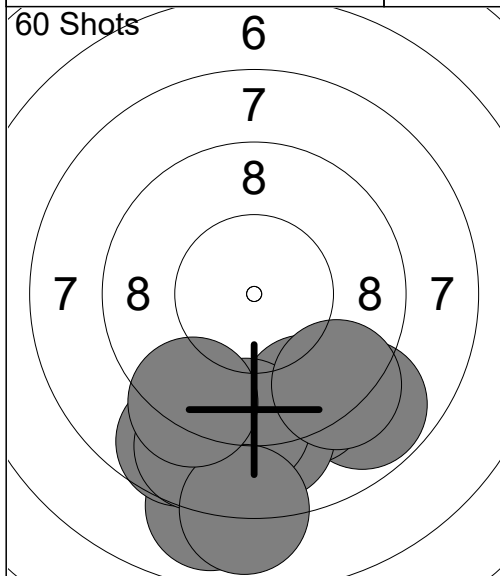

1:	8.0	↓
2:	8.8	↘
3:	9.3	↓
4:	9.0	↓
5:	8.7	↘
6:	8.7	↘
7:	9.2	↓
8:	9.3	↘
9:	8.0	↓
10:	9.2	↘
Series	88.2	
	88.2	

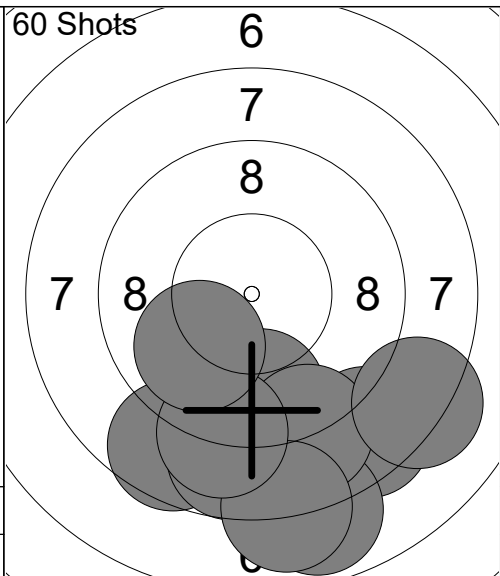

11:	8.5	↘
12:	8.6	↘
13:	7.9	↘
14:	8.7	↓
15:	9.6	↓
16:	8.9	↘
17:	8.0	↓
18:	8.2	↘
19:	9.0	↓
20:	9.9	↙
Series	87.3	
	175.5	

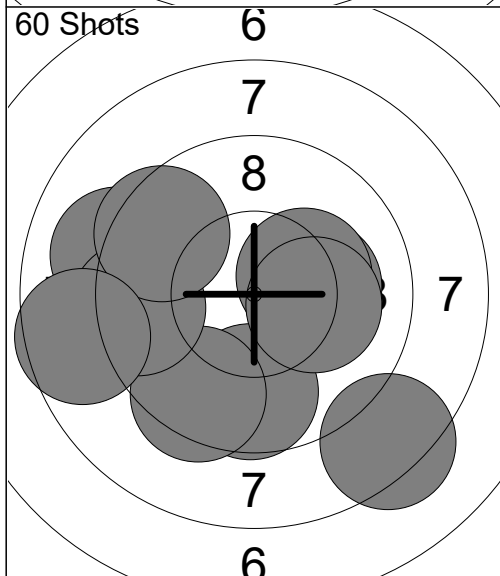

21:	9.7	↓
22:	9.1	↙
23:	9.4	↓
24:	9.4	↙
25:	8.3	↘
26:	10.2x	→
27:	9.5	↗
28:	8.6	↙
29:	10.3x	→
30:	10.1	→
Series	94.6	
	270.1	

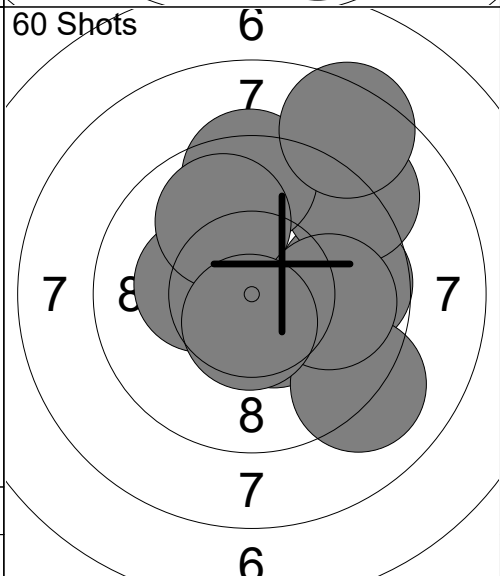

31:	10.3x	↔
32:	9.7	→
33:	9.1	↗
34:	9.4	↑
35:	10.5x	↘
36:	9.1	↘
37:	9.9	↑
38:	9.9	→
39:	10.6x	↓
40:	8.4	↗
Series	96.9	
	367.0	

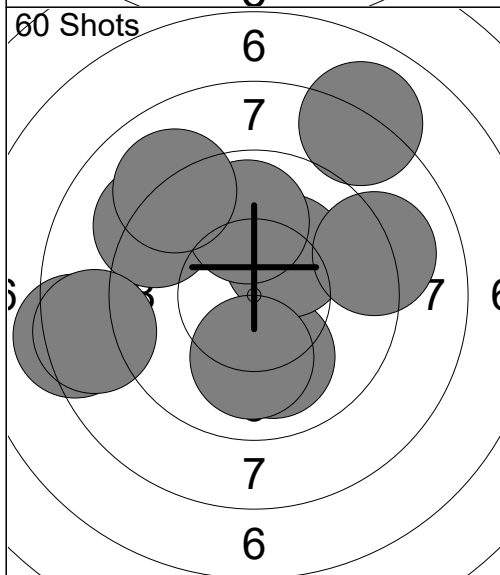

41:	9.2	↙
42:	8.3	↙
43:	10.0	↓
44:	10.2x	↗
45:	9.9	↑
46:	8.0	↗
47:	9.1	↗
48:	10.0	↓
49:	9.1	→
50:	8.6	↙
Series	92.4	
	459.4	

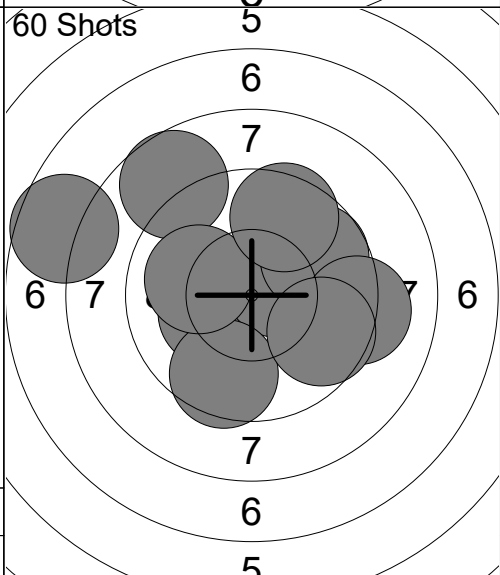

51:	8.7	↖
52:	10.2x	↔
53:	10.5x	↗
54:	9.6	↓
55:	10.0	↙
56:	9.7	↗
57:	9.2	→
58:	9.6	↘
59:	7.6	↙
60:	9.5	↑
Series	94.6	
	554.0	

Relay **3** Lane **37** **LEE Olivia**

1-80 Minnesota Center Shots Precision

31.01.2025 2025 AirNats by X Count Civilian Marksmanship Program

Comment Signature

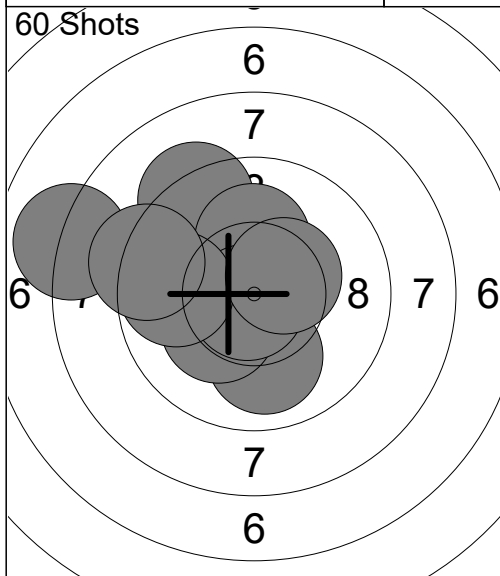

1:	8.0	↙
2:	10.4x	↗
3:	10.0	↓
4:	10.2x	↙
5:	9.3	↗
6:	10.1	↑
7:	10.8x	↙
8:	9.8	←
9:	9.2	↙
10:	10.4x	↗
Series	98.2	
	98.2	

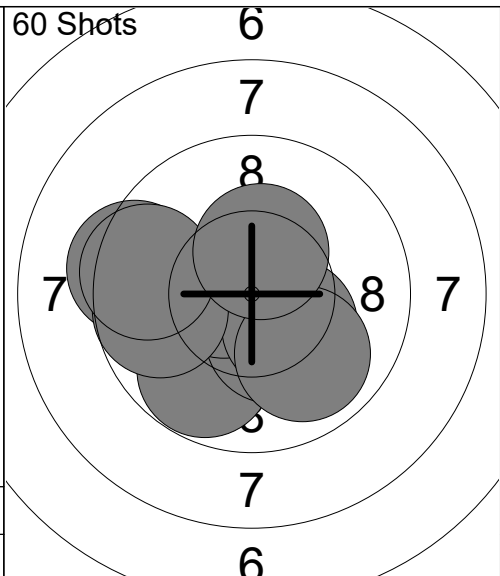

11:	10.3x	↓
12:	9.8	↙
13:	10.3x	↓
14:	10.6x	←
15:	10.3x	↘
16:	9.9	↘
17:	9.4	←
18:	9.7	←
19:	9.5	←
20:	10.4x	↑
Series	100.2	
	198.4	

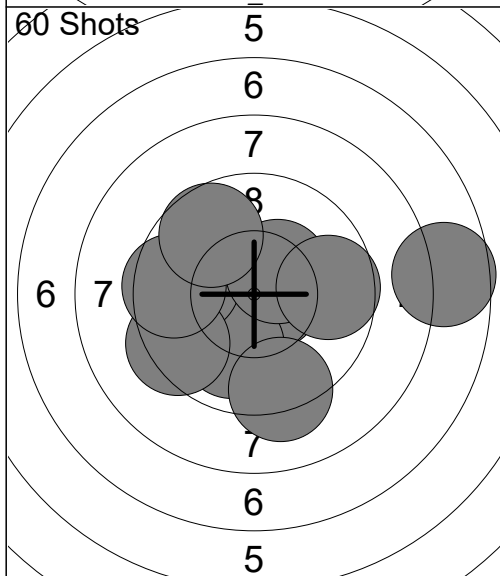

21:	10.7x	→
22:	10.0	↓
23:	9.8	←
24:	10.4x	↗
25:	9.4	←
26:	9.7	→
27:	9.6	←
28:	9.7	↗
29:	9.2	↓
30:	7.7	→
Series	96.2	
	294.6	

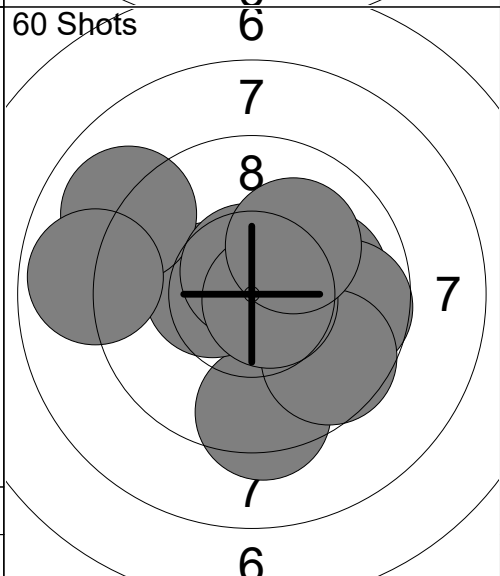

31:	9.4	↓
32:	10.0	→
33:	10.4x	←
34:	9.0	↙
35:	10.6x	↑
36:	9.7	→
37:	9.6	↘
38:	10.7x	→
39:	10.1	↗
40:	8.9	←
Series	98.4	
	393.0	

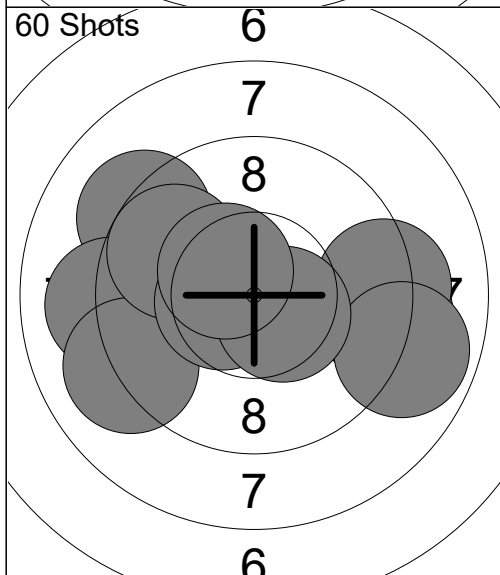

41:	9.2	↙
42:	9.1	←
43:	9.1	←
44:	9.7	↙
45:	10.5x	←
46:	9.2	→
47:	9.2	→
48:	8.9	→
49:	10.5x	↘
50:	10.5x	↗
Series	95.9	
	488.9	

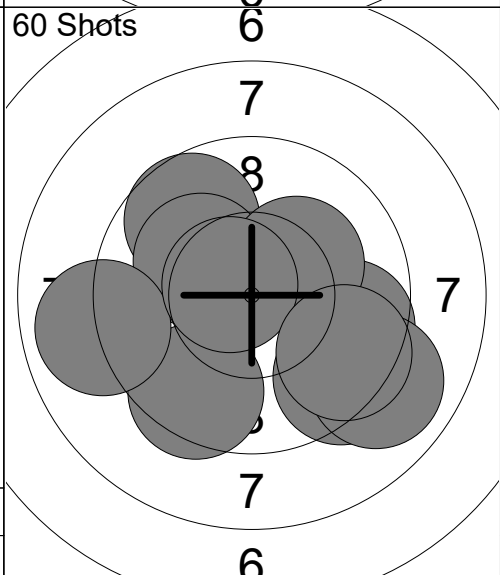

51:	9.7	↗
52:	9.5	↘
53:	10.1	↗
54:	8.9	←
55:	9.6	→
56:	9.3	↘
57:	9.0	↘
58:	10.2x	↗
59:	10.6x	←
60:	9.5	↘
Series	96.4	
	585.3	

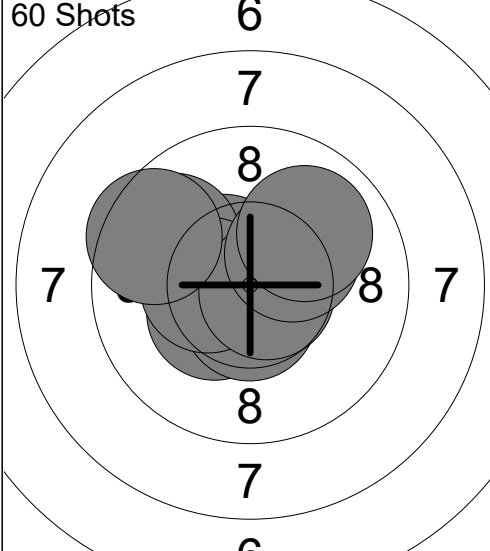
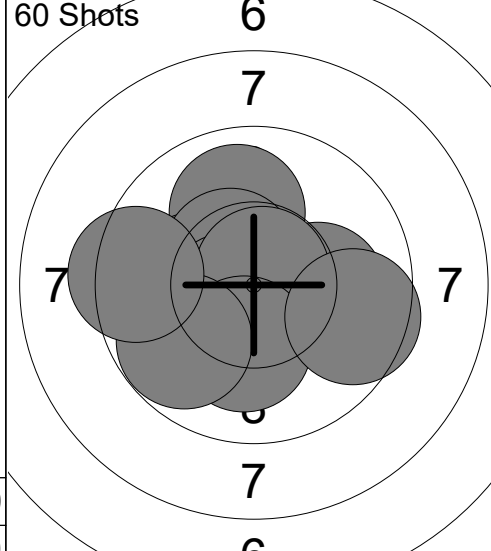
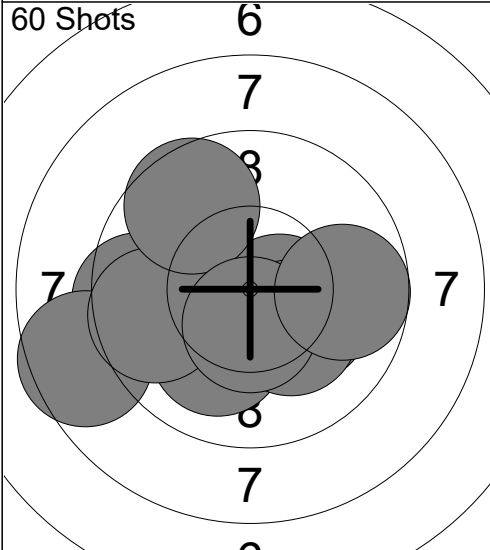
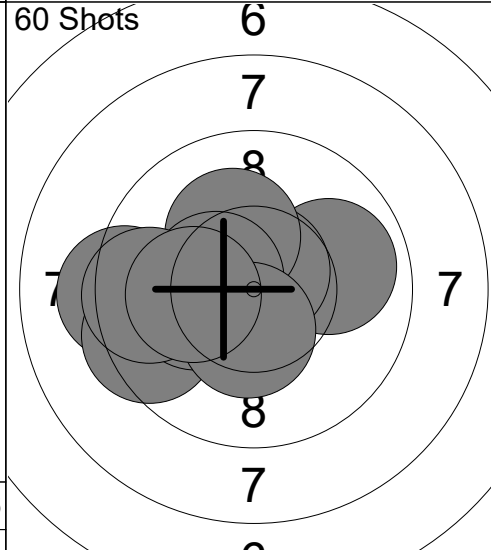
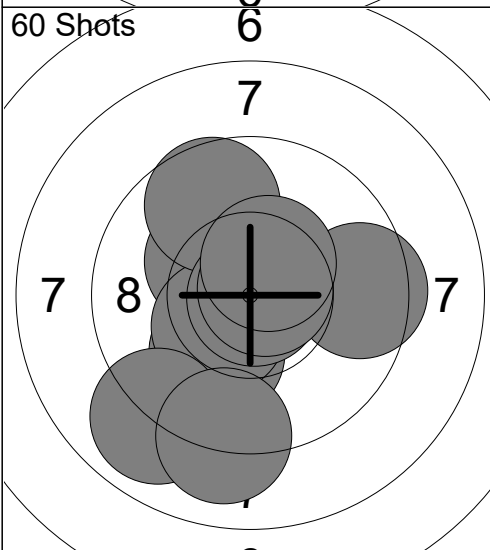
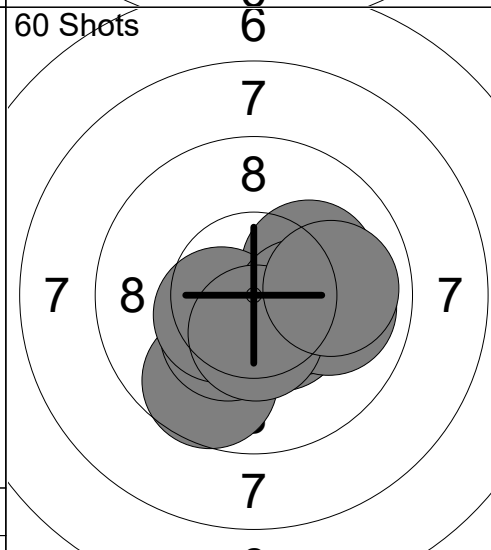
<p>60 Shots</p>  <p style="text-align: center;">6 7 8 7 8 7</p>	<p>1: 10.8x ↙ 2: 10.5x ↖ 3: 10.4x ↙ 4: 9.8 ↖ 5: 10.6x ↓ 6: 10.4x ← 7: 10.7x → 8: 10.3x ↗ 9: 10.0 ↗ 10: 9.5 ↖</p> <p>Series 103.0 103.0</p>	<p>60 Shots</p>  <p style="text-align: center;">6 7 7 7 7 7</p>	<p>11: 10.0 ↑ 12: 10.2x ← 13: 10.1 → 14: 10.5x ↖ 15: 10.6x ↙ 16: 10.8x ↗ 17: 10.2x ↓ 18: 9.6 → 19: 9.8 ↙ 20: 9.4 ←</p> <p>Series 101.2 204.2</p>
<p>60 Shots</p>  <p style="text-align: center;">6 6 7 8 7 7</p>	<p>21: 10.2x → 22: 9.5 ← 23: 10.1 ↓ 24: 8.6 ← 25: 9.7 ← 26: 10.5x → 27: 10.2x ↓ 28: 9.6 ↗ 29: 10.5x ↓ 30: 9.7 →</p> <p>Series 98.6 302.8</p>	<p>60 Shots</p>  <p style="text-align: center;">6 6 7 8 7 7</p>	<p>31: 9.9 → 32: 10.7x ↗ 33: 9.2 ← 34: 10.2x ↗ 35: 9.4 ← 36: 10.4x ← 37: 10.2x ← 38: 9.6 ← 39: 10.4x ↓ 40: 10.1 ←</p> <p>Series 100.1 402.9</p>
<p>60 Shots</p>  <p style="text-align: center;">6 6 7 7 7 6</p>	<p>41: 9.5 → 42: 10.1 ↓ 43: 10.3x ↖ 44: 10.4x ↙ 45: 9.7 ↗ 46: 10.9x → 47: 10.7x → 48: 10.5x ↗ 49: 8.9 ↙ 50: 9.1 ↓</p> <p>Series 100.1 503.0</p>	<p>60 Shots</p>  <p style="text-align: center;">6 6 7 8 7 6</p>	<p>51: 10.4x → 52: 9.7 ↙ 53: 10.1 → 54: 10.3x ↙ 55: 10.5x ↓ 56: 10.5x ↙ 57: 10.3x → 58: 9.9 → 59: 10.4x ↓ 60: 9.9 →</p> <p>Series 102.0 605.0</p>

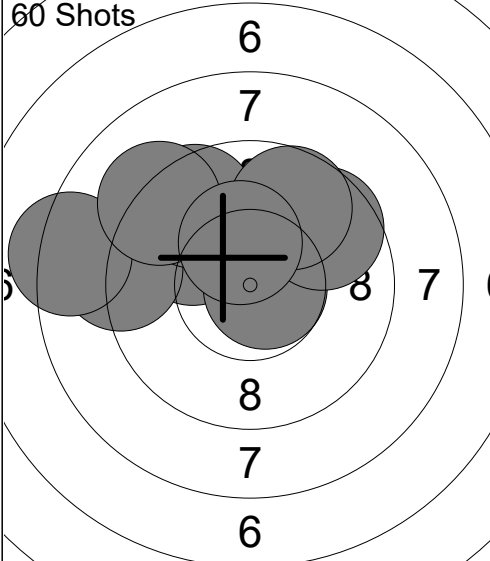
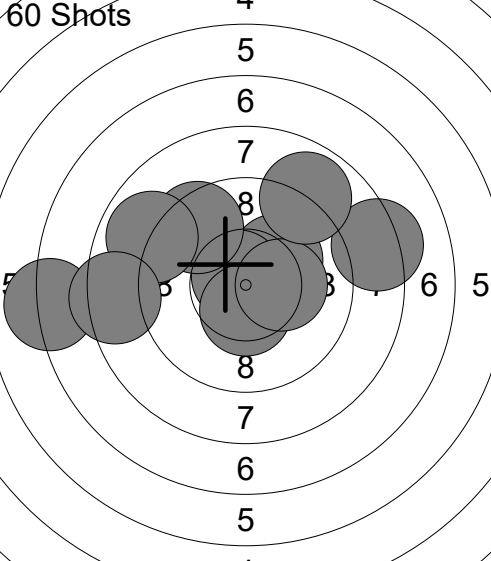
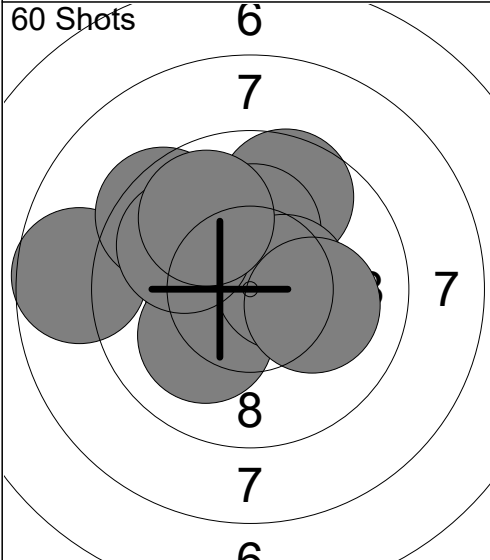
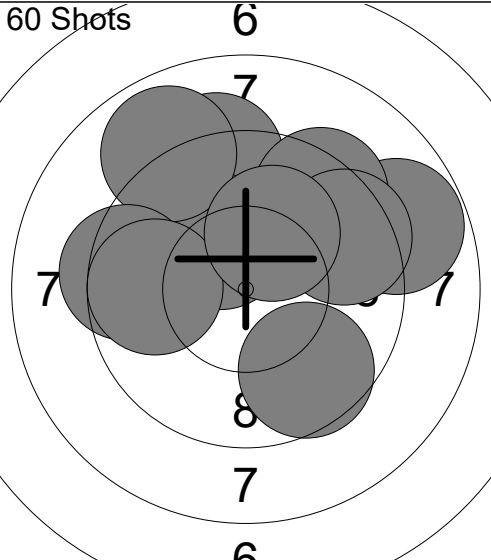
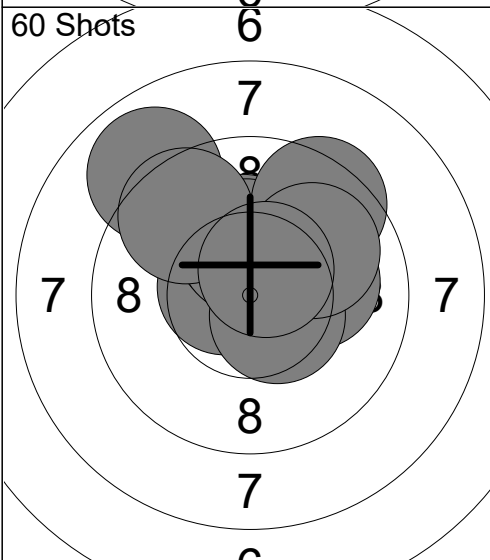
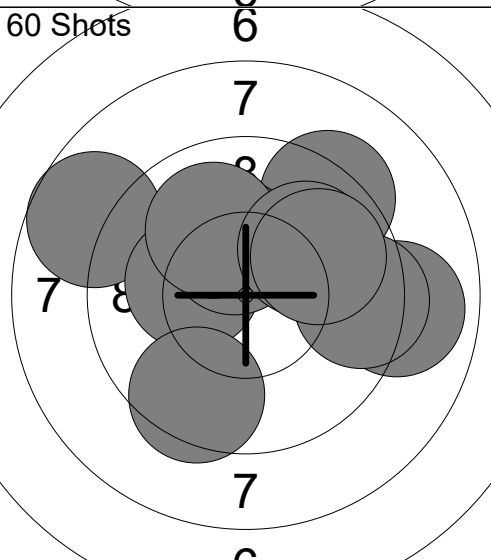
<p>60 Shots</p> 	<p>1: 9.9 ↖ 2: 9.1 ← 3: 10.4x ↑ 4: 10.7x → 5: 8.3 ← 6: 9.6 → 7: 9.6 ↗ 8: 9.2 ↗ 9: 9.7 ↗ 10: 10.3x ↑</p> <p>Series 96.8 96.8</p>	<p>60 Shots</p> 	<p>11: 10.2x ↗ 12: 8.3 → 13: 10.7x ↖ 14: 10.5x ↓ 15: 10.3x → 16: 8.9 ↗ 17: 9.5 ↖ 18: 8.9 ↖ 19: 7.1 ← 20: 8.4 ←</p> <p>Series 92.8 189.6</p>
<p>60 Shots</p> 	<p>21: 9.6 ↗ 22: 10.4x ← 23: 10.1 ↙ 24: 10.2x ↑ 25: 8.7 ← 26: 9.4 ↖ 27: 10.5x → 28: 9.9 ↖ 29: 10.1 → 30: 9.8 ↗</p> <p>Series 98.7 288.3</p>	<p>60 Shots</p> 	<p>31: 8.8 → 32: 9.2 ↑ 33: 10.2x ↗ 34: 8.9 ↗ 35: 9.4 ↗ 36: 9.6 ↓ 37: 9.4 ← 38: 9.7 ← 39: 9.5 → 40: 10.1 ↗</p> <p>Series 94.8 383.1</p>
<p>60 Shots</p> 	<p>41: 10.6x ← 42: 10.1 → 43: 10.5x ↘ 44: 10.2x ↑ 45: 8.9 ↗ 46: 10.3x ↑ 47: 9.4 ↗ 48: 9.9 ↗ 49: 9.6 ↖ 50: 10.6x ↗</p> <p>Series 100.1 483.2</p>	<p>60 Shots</p> 	<p>51: 9.3 ↗ 52: 8.7 ↖ 53: 10.2x ← 54: 8.9 → 55: 10.3x ↑ 56: 10.0 ↗ 57: 10.0 ↗ 58: 9.4 → 59: 9.9 → 60: 9.5 ↓</p> <p>Series 96.2 579.4</p>

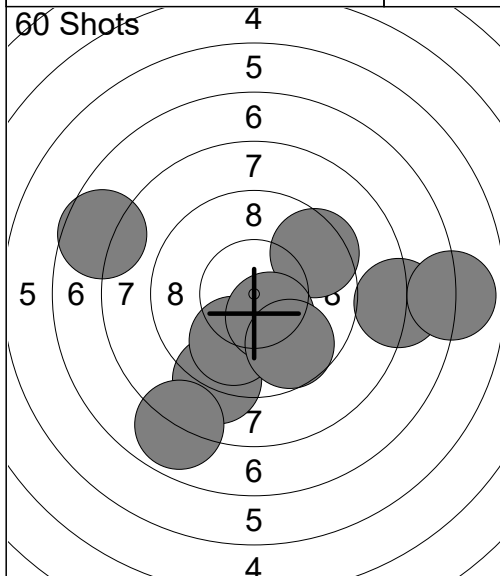

1:	10.3x	↓
2:	8.0	→
3:	9.5	↗
4:	9.1	↓
5:	7.9	↓
6:	6.9	→
7:	9.9	↓
8:	10.4x	↓
9:	7.6	↖
10:	9.7	↓
Series	89.3	
	89.3	

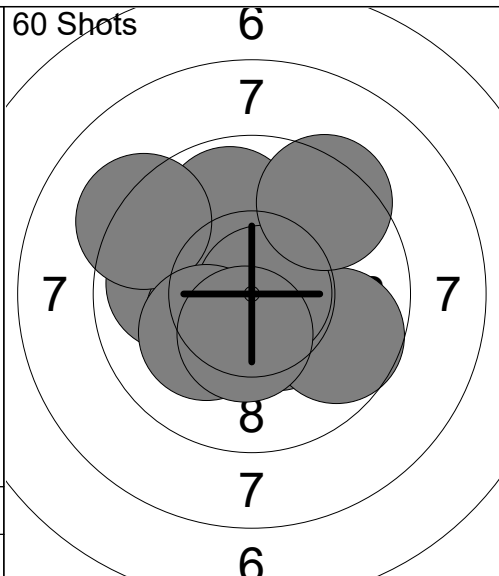

11:	9.9	←
12:	10.4x	↙
13:	10.5x	↓
14:	9.7	↘
15:	9.9	↑
16:	10.8x	→
17:	9.4	↗
18:	9.2	↖
19:	10.2x	↙
20:	10.4x	↓
Series	100.4	
	189.7	

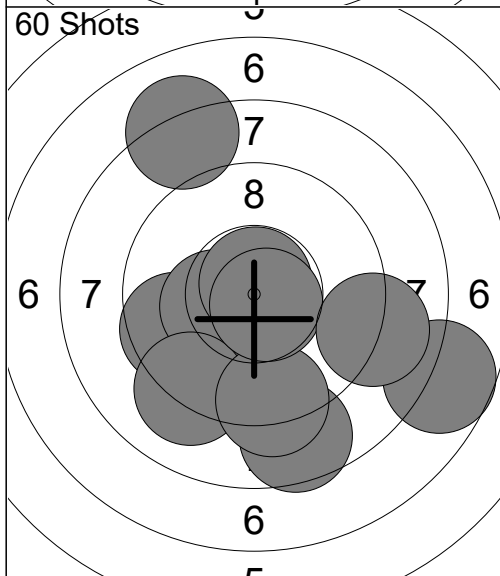

21:	9.6	←
22:	8.1	↑
23:	10.3x	←
24:	10.8x	↑
25:	8.6	↓
26:	9.1	↓
27:	7.7	→
28:	9.2	↓
29:	10.7x	↓
30:	9.0	→
Series	93.1	
	282.8	

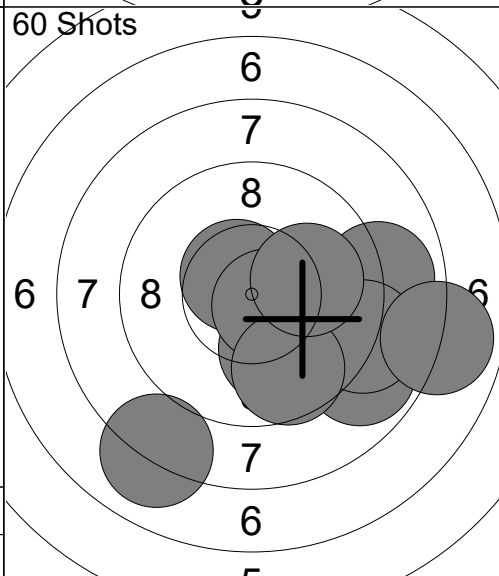

31:	8.0	↓
32:	8.9	↘
33:	8.9	→
34:	9.1	↘
35:	10.0	↓
36:	10.6x	↗
37:	10.6x	↘
38:	9.6	↓
39:	10.0	→
40:	7.9	→
Series	93.6	
	376.4	

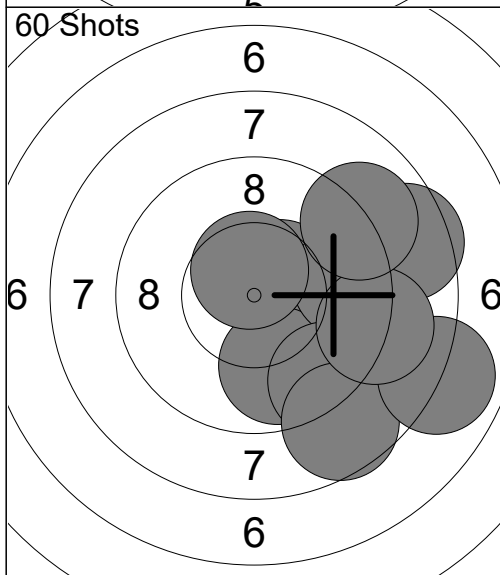

41:	10.5x	↗
42:	9.8	↓
43:	9.5	→
44:	9.3	↘
45:	10.6x	↑
46:	8.6	↓
47:	8.5	→
48:	7.9	↘
49:	9.0	→
50:	9.0	↗
Series	92.7	
	469.1	

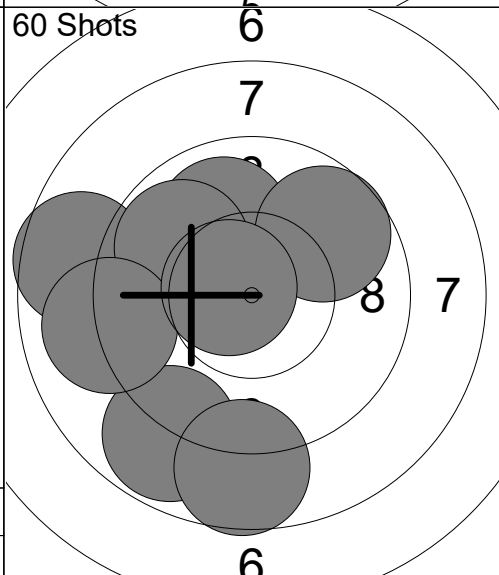

51:	9.3	←
52:	9.9	↑
53:	9.0	←
54:	9.7	↗
55:	8.8	↓
56:	8.6	←
57:	8.7	↓
58:	9.8	↖
59:	9.0	←
60:	10.6x	↙
Series	93.4	
	562.5	

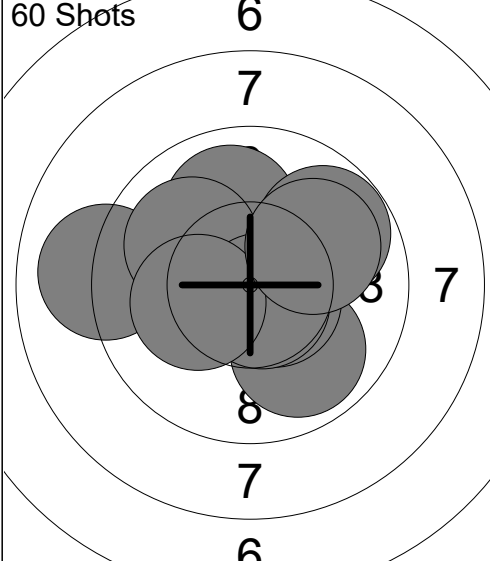
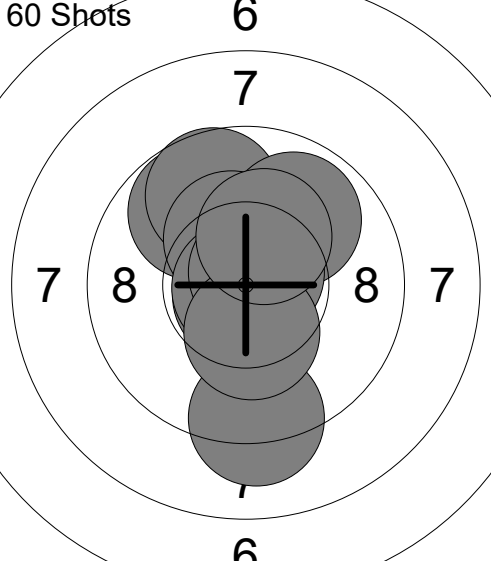
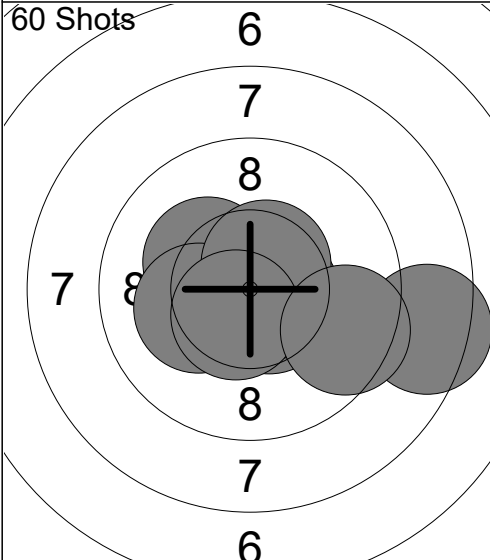
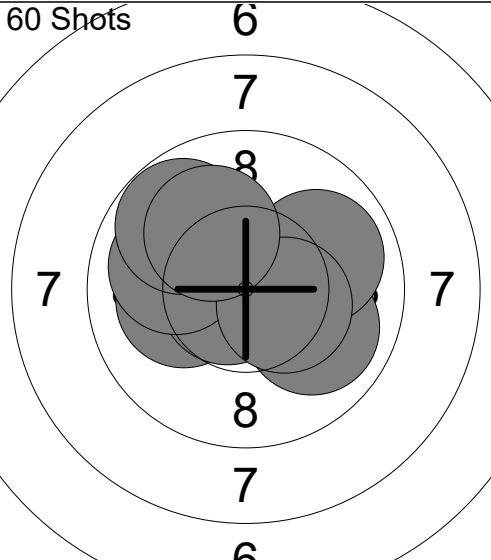
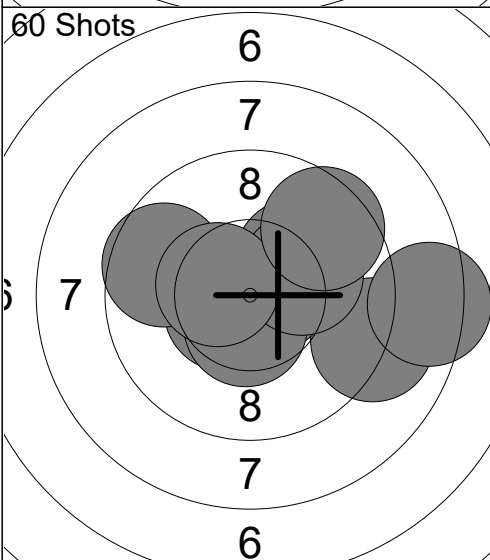
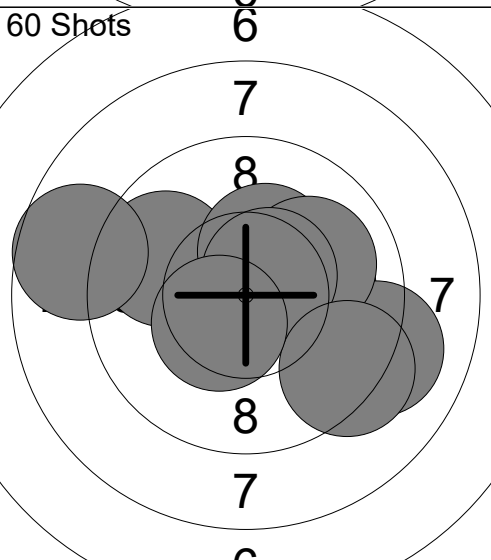
<p>60 Shots</p>  <p style="text-align: center;">6 7 7 8 7 7 8 7 7 7</p>	<p>1: 9.9 ↘ 2: 10.6x ↘ 3: 10.1 ← 4: 9.0 ← 5: 10.0 ↑ 6: 10.0 ↗ 7: 10.7x ↘ 8: 9.8 ↗ 9: 10.2x ← 10: 10.0 ↗</p> <p>Series 100.3</p>	<p>60 Shots</p>  <p style="text-align: center;">6 7 7 8 7 8 8 7 7 7</p>	<p>11: 9.8 ↗ 12: 9.7 ↑ 13: 9.9 ↗ 14: 10.3x ↑ 15: 9.2 ↓ 16: 10.8x ↘ 17: 10.9x ← 18: 10.7x ↗ 19: 10.3x ↓ 20: 10.3x ↑</p> <p>Series 101.9</p>
	100.3		202.2
<p>60 Shots</p>  <p style="text-align: center;">6 6 7 8 7 8 8 8 7 7</p>	<p>21: 10.4x ← 22: 10.6x ↘ 23: 10.6x → 24: 10.6x ↘ 25: 10.3x ↗ 26: 10.2x ← 27: 10.5x ↗ 28: 8.4 → 29: 10.5x ↘ 30: 9.5 →</p> <p>Series 101.6</p>	<p>60 Shots</p>  <p style="text-align: center;">6 6 7 8 7 8 8 7 7 7</p>	<p>31: 10.1 ← 32: 10.5x ↗ 33: 9.9 ↘ 34: 10.7x ← 35: 10.4x ↗ 36: 10.0 ← 37: 9.9 → 38: 10.4x → 39: 9.8 ↗ 40: 10.1 ↗</p> <p>Series 101.8</p>
	303.8		405.6
<p>60 Shots</p>  <p style="text-align: center;">6 6 7 8 7 8 8 7 7 7</p>	<p>41: 9.1 → 42: 8.3 → 43: 10.5x ← 44: 9.6 ← 45: 10.7x → 46: 10.1 ↗ 47: 10.5x ↘ 48: 10.1 → 49: 10.4x ← 50: 9.5 ↗</p> <p>Series 98.8</p>	<p>60 Shots</p>  <p style="text-align: center;">6 6 7 8 7 8 8 7 7 7</p>	<p>51: 9.8 ← 52: 10.1 → 53: 10.4x ↗ 54: 8.7 ← 55: 9.1 → 56: 10.3x ↑ 57: 10.0 ↗ 58: 10.5x ↗ 59: 9.3 ↘ 60: 10.4x ↘</p> <p>Series 98.6</p>
	504.4		603.0

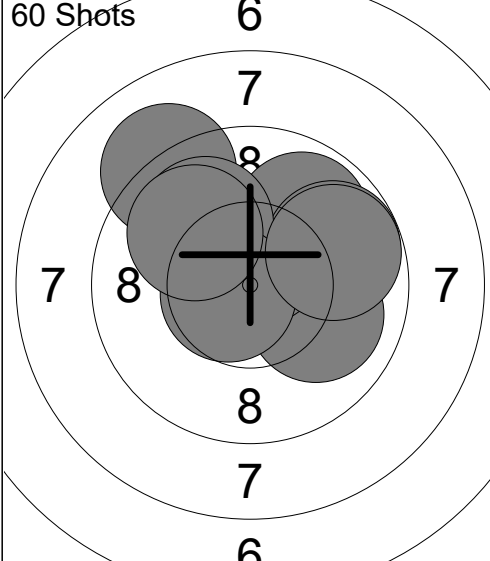
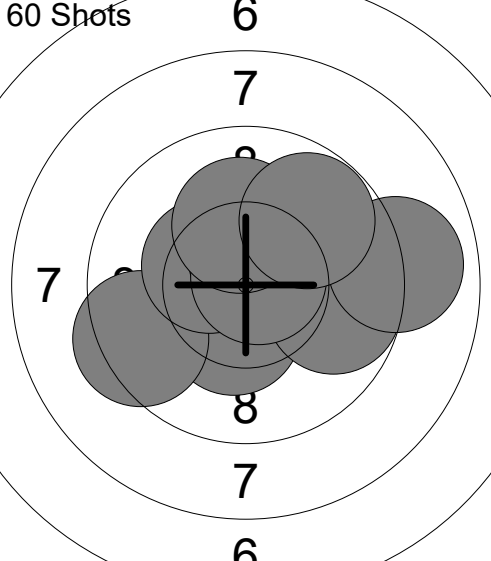
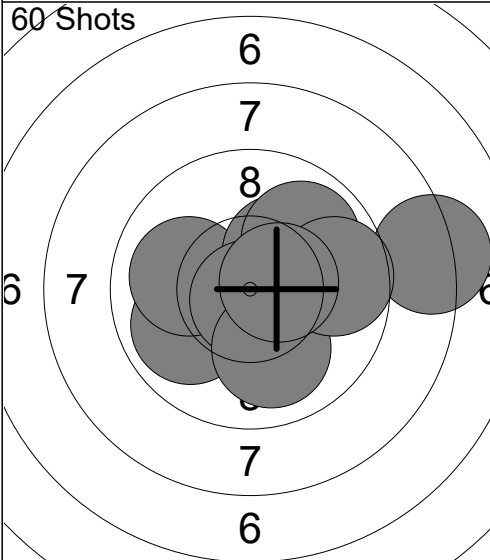
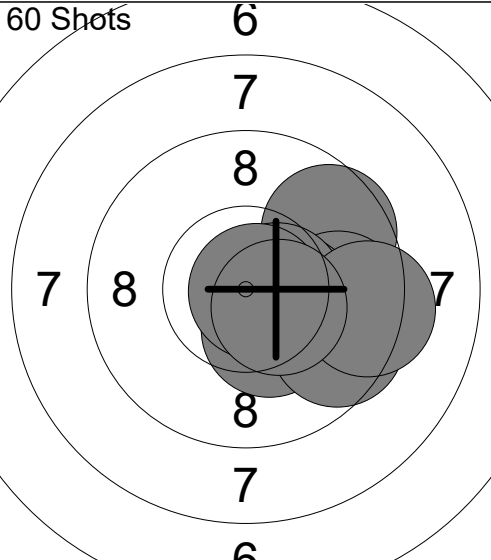
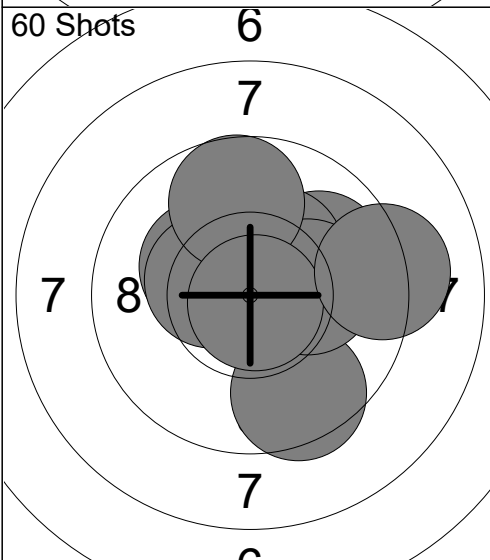
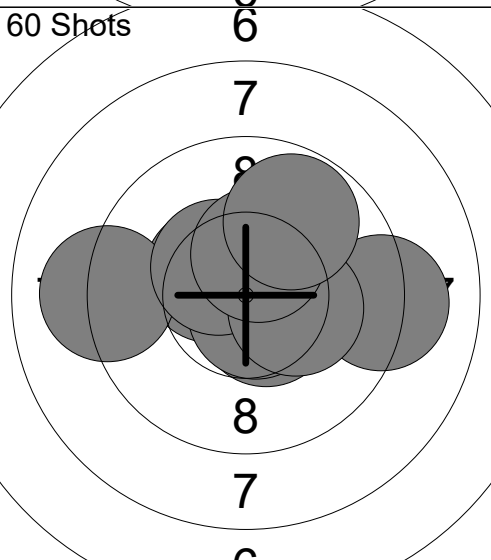
<p>60 Shots</p> 	<p>1: 10.0 ➤ 2: 10.2x ↗ 3: 9.1 ↖ 4: 10.6x ↗ 5: 9.9 ↗ 6: 9.8 ➔ 7: 9.9 ↖ 8: 10.6x ↖ 9: 9.8 ➔ 10: 9.9 ↖</p> <p>Series 99.8</p> <p style="text-align: right;">99.8</p>	<p>60 Shots</p> 	<p>11: 10.4x ↘ 12: 9.4 ↖ 13: 10.4x ↖ 14: 10.6x ↗ 15: 9.8 ➔ 16: 10.4x ↗ 17: 10.7x ↗ 18: 10.1 ↗ 19: 8.9 ➔ 20: 9.8 ↗</p> <p>Series 100.5</p> <p style="text-align: right;">200.3</p>
<p>60 Shots</p> 	<p>21: 9.9 ↖ 22: 10.0 ↖ 23: 10.3x ↗ 24: 10.2x ↗ 25: 10.8x ↘ 26: 8.2 ➔ 27: 9.9 ↗ 28: 10.0 ↘ 29: 9.7 ➔ 30: 10.5x ➔</p> <p>Series 99.5</p> <p style="text-align: right;">299.8</p>	<p>60 Shots</p> 	<p>31: 10.1 ➔ 32: 9.6 ↗ 33: 9.7 ➔ 34: 10.3x ➔ 35: 10.5x ➔ 36: 10.3x ↘ 37: 10.8x ➔ 38: 9.6 ↘ 39: 9.3 ➔ 40: 10.5x ↘</p> <p>Series 100.7</p> <p style="text-align: right;">400.5</p>
<p>60 Shots</p> 	<p>41: 9.5 ↘ 42: 9.9 ↗ 43: 10.8x ↘ 44: 10.3x ↗ 45: 10.2x ➔ 46: 10.3x ↖ 47: 10.4x ↖ 48: 9.7 ↗ 49: 10.8x ↘ 50: 9.2 ➔</p> <p>Series 101.1</p> <p style="text-align: right;">501.6</p>	<p>60 Shots</p> 	<p>51: 10.4x ↖ 52: 10.5x ↘ 53: 10.3x ➔ 54: 10.7x ↘ 55: 9.2 ➔ 56: 9.1 ↖ 57: 10.4x ↖ 58: 10.3x ➔ 59: 10.4x ↗ 60: 9.8 ↗</p> <p>Series 101.1</p> <p style="text-align: right;">602.7</p>

<p>60 Shots</p>	<p>1: 10.3x ↘ 2: 9.9 ↖ 3: 10.4x → 4: 9.9 ↙ 5: 9.6 ↖ 6: 10.5x ← 7: 9.4 ↖ 8: 10.3x ← 9: 10.4x ↗ 10: 10.4x ↙</p> <p>Series 101.1 101.1</p>	<p>60 Shots</p>	<p>11: 9.5 ↗ 12: 9.8 → 13: 10.5x ↑ 14: 10.0 ↗ 15: 10.1 ↖ 16: 10.7x ↓ 17: 10.3x ↑ 18: 10.7x ↖ 19: 10.1 ↖ 20: 10.3x ↗</p> <p>Series 102.0 203.1</p>
<p>60 Shots</p>	<p>21: 10.7x ↑ 22: 10.6x ↖ 23: 10.3x ↖ 24: 10.8x ← 25: 10.1 ↖ 26: 10.0 ↗ 27: 9.8 ↖ 28: 10.5x ↘ 29: 10.3x ↑ 30: 10.5x ↗</p> <p>Series 103.6 306.7</p>	<p>60 Shots</p>	<p>31: 10.1 ↗ 32: 10.2x → 33: 10.0 ↖ 34: 10.7x ↖ 35: 10.5x ↖ 36: 10.2x ↑ 37: 9.8 ↖ 38: 10.0 ↑ 39: 9.9 ↖ 40: 9.9 ↖</p> <p>Series 101.3 408.0</p>
<p>60 Shots</p>	<p>41: 9.9 ↖ 42: 10.3x ↗ 43: 9.5 → 44: 10.9x → 45: 10.7x ↗ 46: 10.2x ↓ 47: 10.5x ↖ 48: 9.8 → 49: 10.7x ↖ 50: 10.3x ↑</p> <p>Series 102.8 510.8</p>	<p>60 Shots</p>	<p>51: 9.8 ↖ 52: 9.9 ↗ 53: 10.7x ↘ 54: 9.9 ↗ 55: 9.6 ↖ 56: 9.5 ↖ 57: 10.4x ↑ 58: 10.3x ↗ 59: 10.6x ↗ 60: 10.4x ↑</p> <p>Series 101.1 611.9</p>

<p>60 Shots</p>	<p>1: 9.3 ↗</p> <p>2: 9.3 ←</p> <p>3: 9.7 →</p> <p>4: 10.0 ↗</p> <p>5: 9.9 ↗</p> <p>6: 8.2 ←</p> <p>7: 8.1 ↗</p> <p>8: 9.9 →</p> <p>9: 8.6 ←</p> <p>10: 10.5x ↓</p> <hr/> <p>Series 93.5</p> <p style="text-align: center;">93.5</p>	<p>60 Shots</p>	<p>11: 9.9 ←</p> <p>12: 10.2x ↑</p> <p>13: 9.5 →</p> <p>14: 9.2 ↗</p> <p>15: 8.9 ↗</p> <p>16: 10.6x ←</p> <p>17: 8.8 ↗</p> <p>18: 9.1 ↑</p> <p>19: 10.8x ↘</p> <p>20: 10.5x →</p> <hr/> <p>Series 97.5</p> <p style="text-align: center;">191.0</p>
<p>60 Shots</p>	<p>21: 8.9 ↗</p> <p>22: 9.6 ↘</p> <p>23: 9.7 ↑</p> <p>24: 7.9 ↑</p> <p>25: 9.3 ↗</p> <p>26: 10.0 ↗</p> <p>27: 9.9 ↑</p> <p>28: 8.6 ←</p> <p>29: 10.8x ←</p> <p>30: 8.8 ↗</p> <hr/> <p>Series 93.5</p> <p style="text-align: center;">284.5</p>	<p>60 Shots</p>	<p>31: 9.7 ↗</p> <p>32: 10.0 ↘</p> <p>33: 10.7x ←</p> <p>34: 10.1 →</p> <p>35: 9.1 →</p> <p>36: 9.8 ↗</p> <p>37: 9.8 ↑</p> <p>38: 9.8 ↗</p> <p>39: 9.1 ←</p> <p>40: 9.2 ↗</p> <hr/> <p>Series 97.3</p> <p style="text-align: center;">381.8</p>
<p>60 Shots</p>	<p>41: 8.9 ←</p> <p>42: 10.5x ←</p> <p>43: 10.7x ↓</p> <p>44: 9.9 ←</p> <p>45: 9.8 ↑</p> <p>46: 9.3 ↗</p> <p>47: 9.7 ↑</p> <p>48: 10.2x ←</p> <p>49: 9.6 ↗</p> <p>50: 9.8 ↑</p> <hr/> <p>Series 98.4</p> <p style="text-align: center;">480.2</p>	<p>60 Shots</p>	<p>51: 9.5 ←</p> <p>52: 8.8 ↗</p> <p>53: 10.0 →</p> <p>54: 10.2x ↘</p> <p>55: 10.3x →</p> <p>56: 8.9 →</p> <p>57: 8.1 ↗</p> <p>58: 9.6 ↗</p> <p>59: 10.3x ←</p> <p>60: 9.8 ↘</p> <hr/> <p>Series 95.5</p> <p style="text-align: center;">575.7</p>

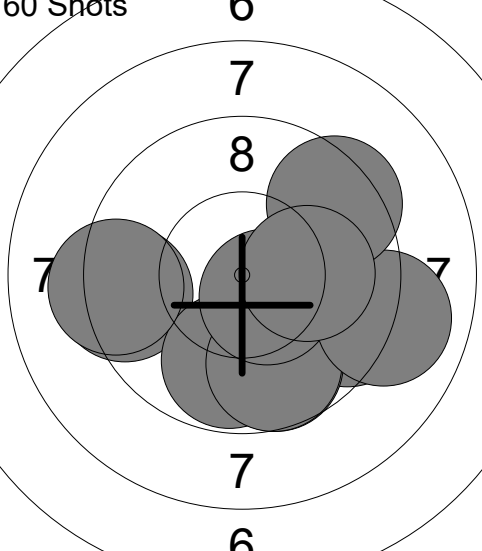
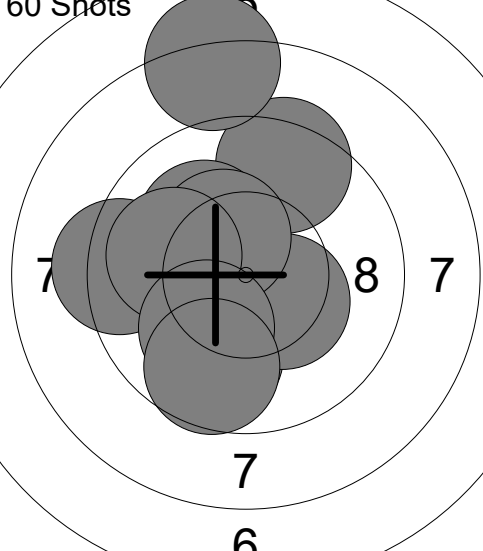
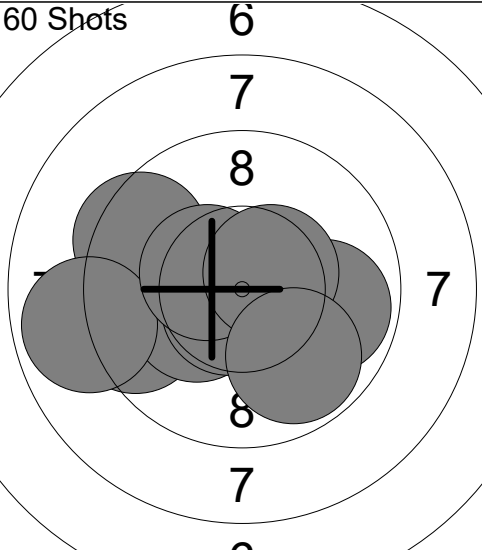
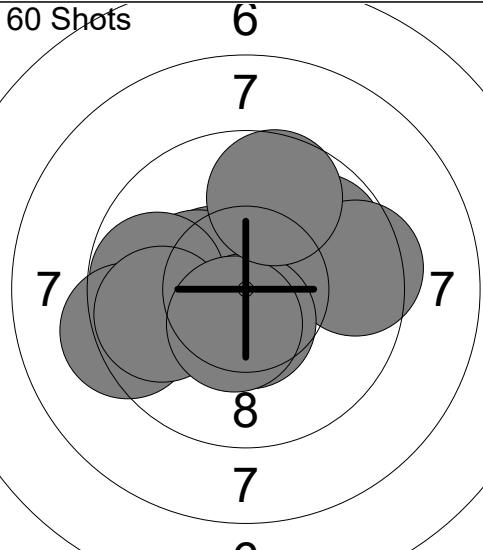
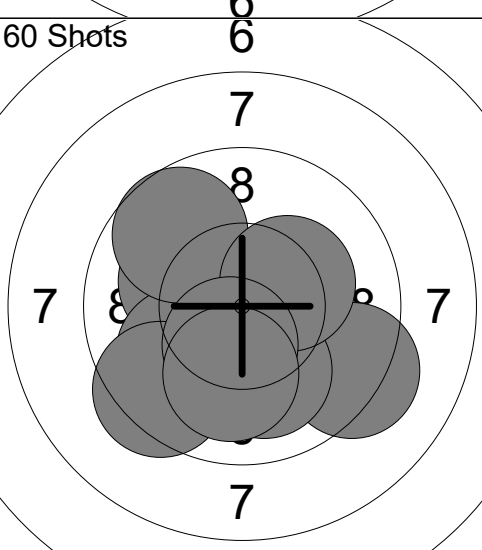
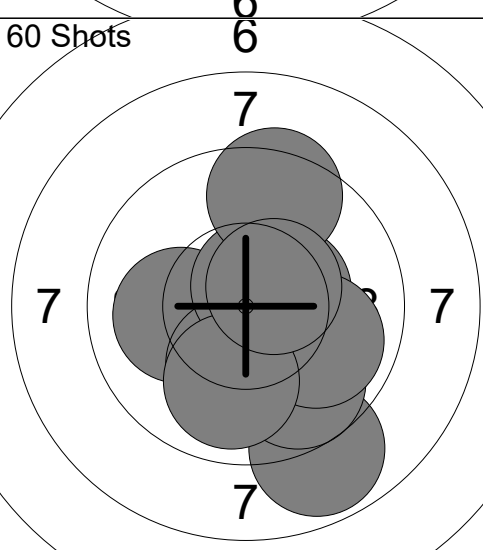
<p>60 Shots</p> 	<p>1: 9.4 ← 2: 9.4 → 3: 9.8 ↓ 4: 9.7 ↓ 5: 9.3 ← 6: 9.7 ↓ 7: 10.5x ↓ 8: 9.0 → 9: 9.4 ↗ 10: 10.1 →</p> <p>Series 96.3 96.3</p>	<p>60 Shots</p> 	<p>11: 9.8 ↓ 12: 9.3 ← 13: 9.4 ↗ 14: 10.1 ↗ 15: 10.4x → 16: 8.1 ↑ 17: 10.4x ↗ 18: 10.0 ← 19: 10.1 ↓ 20: 9.7 ↓</p> <p>Series 97.3 193.6</p>
<p>60 Shots</p> 	<p>21: 9.5 ← 22: 10.2x ← 23: 10.3x ← 24: 10.6x ↓ 25: 9.5 ↖ 26: 8.9 ← 27: 10.4x ↖ 28: 9.9 → 29: 10.5x ↗ 30: 9.8 ↓</p> <p>Series 99.6 293.2</p>	<p>60 Shots</p> 	<p>31: 10.5x ↖ 32: 10.3x ↖ 33: 9.8 ← 34: 9.8 ↗ 35: 9.3 ← 36: 9.8 ← 37: 9.5 → 38: 10.5x ↓ 39: 10.5x ↓ 40: 9.7 ↑</p> <p>Series 99.7 392.9</p>
<p>60 Shots</p> 	<p>41: 10.6x → 42: 10.1 ↖ 43: 9.3 → 44: 10.1 ↓ 45: 10.0 ← 46: 9.7 ↗ 47: 10.3x → 48: 9.4 ↓ 49: 10.4x ↓ 50: 10.0 ↓</p> <p>Series 99.9 492.8</p>	<p>60 Shots</p> 	<p>51: 10.1 ← 52: 10.2x ↓ 53: 8.8 ↓ 54: 10.6x ↗ 55: 10.4x → 56: 9.7 ↓ 57: 9.4 ↑ 58: 9.9 → 59: 9.9 ↓ 60: 10.5x ↗</p> <p>Series 99.5 592.3</p>

Relay 3	Lane 46	AKINS Ashlyn
-------------------	-------------------	---------------------

1-80	DARC Precision	Precision
------	----------------	-----------

31.01.2025	2025 AirNats by X Count	Civilian Marksmanship Program
------------	-------------------------	-------------------------------

Comment	Signature
---------	-----------

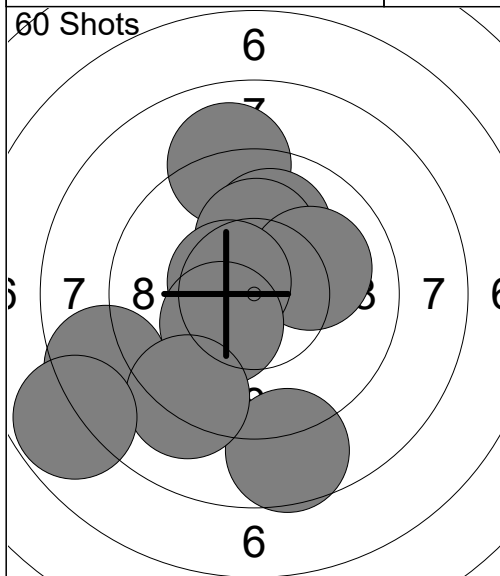

1:	9.0	↑
2:	10.0	↑
3:	10.2x	↑
4:	8.6	↓
5:	10.1	→
6:	8.6	←
7:	10.5x	←
8:	10.3x	↙
9:	9.2	↓
10:	7.8	↙
Series	94.3	
	94.3	

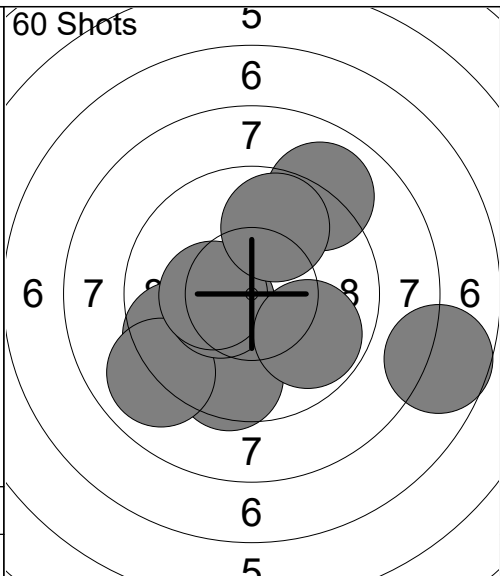

11:	7.7	→
12:	9.7	↙
13:	9.5	←
14:	9.5	↓
15:	9.0	↙
16:	10.4x	←
17:	10.3x	←
18:	9.0	↗
19:	9.8	→
20:	9.8	↑
Series	94.7	
	189.0	

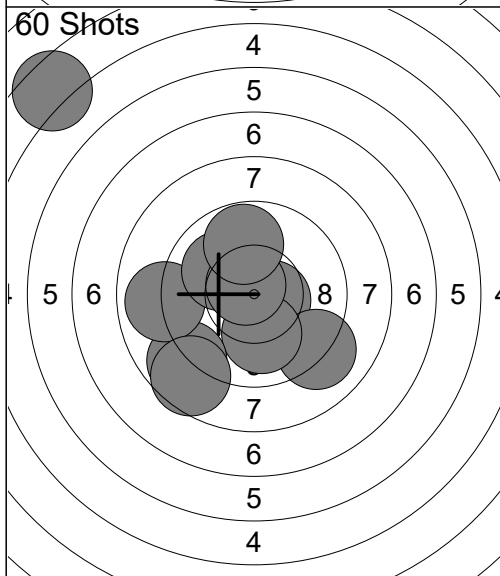

21:	10.6x	→
22:	9.1	↘
23:	10.0	↓
24:	8.8	↙
25:	8.9	←
26:	10.1	↗
27:	10.7x	↗
28:	9.8	↑
29:	8.6	↙
30:	4.5	↗
Series	91.1	
	280.1	

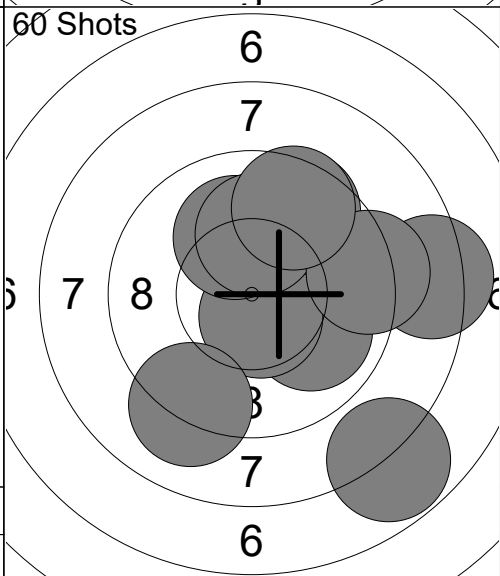

31:	7.8	↘
32:	10.0	→
33:	10.6x	↓
34:	8.3	→
35:	10.1	↑
36:	9.6	↗
37:	10.1	↑
38:	9.2	→
39:	9.1	↙
40:	9.6	↗
Series	94.4	
	374.5	

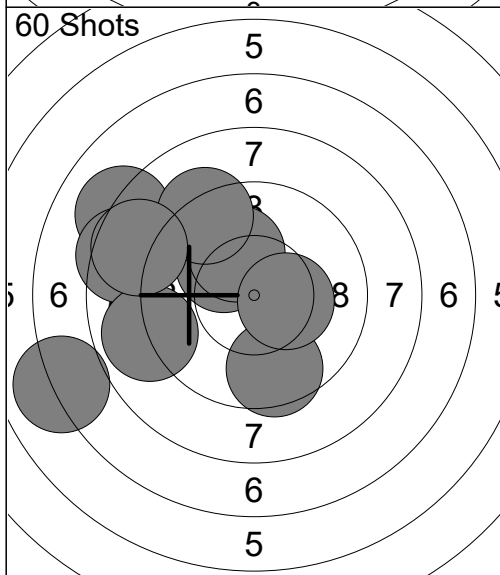

41:	10.1	↗
42:	8.1	↗
43:	8.4	←
44:	10.1	↑
45:	9.5	↓
46:	8.9	←
47:	10.4x	→
48:	7.0	←
49:	9.2	↗
50:	8.6	←
Series	90.3	
	464.8	

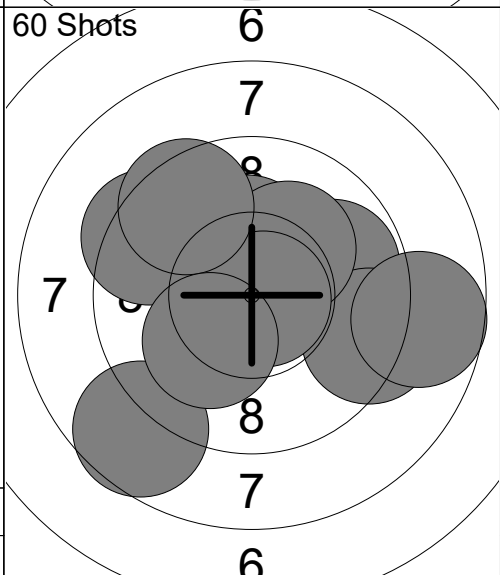

51:	10.3x	↑
52:	9.8	→
53:	9.4	←
54:	9.3	→
55:	8.6	↙
56:	10.2x	↗
57:	10.8x	→
58:	8.7	→
59:	9.5	↗
60:	10.1	↙
Series	96.7	
	561.5	

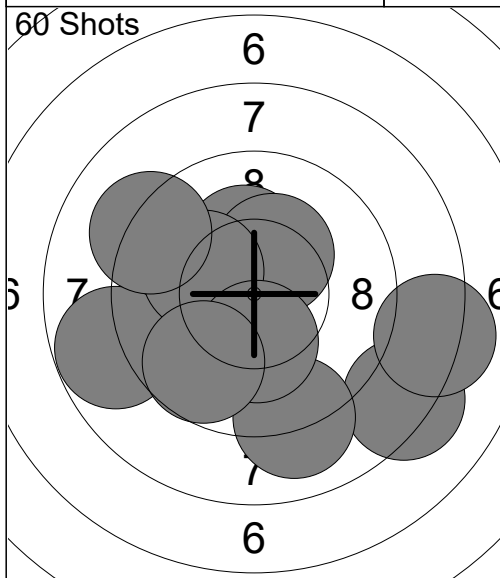

1:	8.3	↘
2:	8.2	→
3:	10.2x	↑
4:	8.8	←
5:	9.0	↓
6:	10.3x	↑
7:	10.1	↖
8:	10.2x	↓
9:	9.7	↘
10:	9.2	↖
Series	94.0	
	94.0	

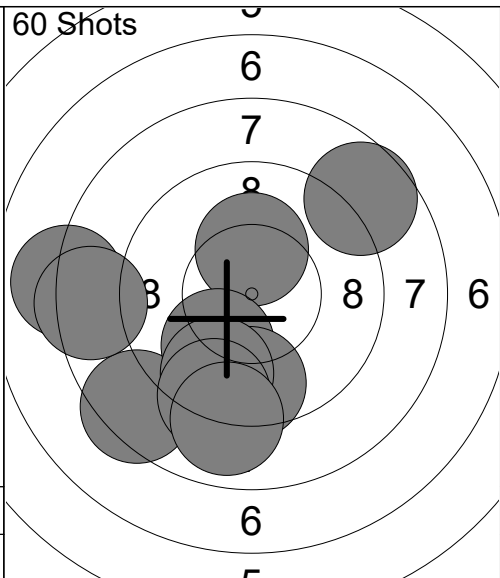

11:	8.4	↘
12:	10.2x	↑
13:	10.0	↘
14:	8.0	←
15:	8.4	←
16:	9.5	↓
17:	8.7	↗
18:	9.6	↘
19:	9.2	↘
20:	8.9	↓
Series	90.9	
	184.9	

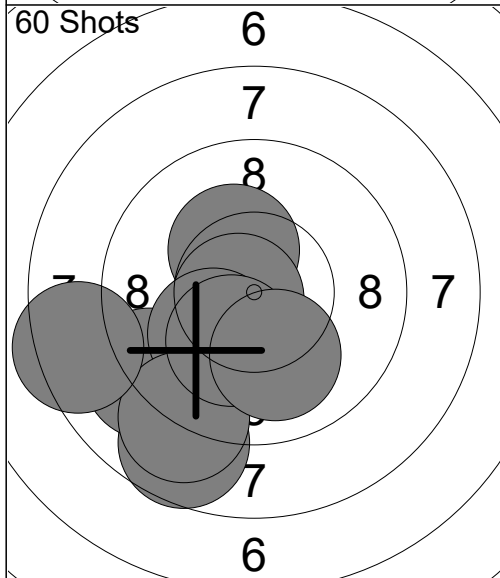

21:	10.3x	↗
22:	9.3	↘
23:	10.7x	←
24:	8.7	↘
25:	9.1	←
26:	10.1	↘
27:	9.0	↘
28:	10.2x	↘
29:	8.4	←
30:	10.0	↓
Series	95.8	
	280.7	

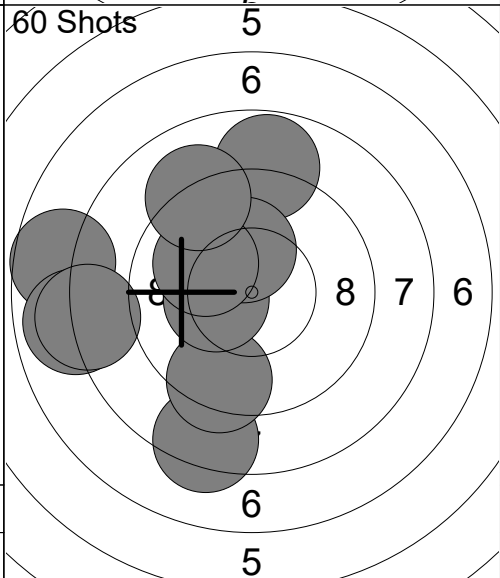

31:	8.3	↓
32:	9.4	↘
33:	10.3x	←
34:	8.8	↑
35:	10.2x	↑
36:	10.0	↖
37:	7.7	←
38:	9.1	↗
39:	7.9	←
40:	8.1	←
Series	89.8	
	370.5	

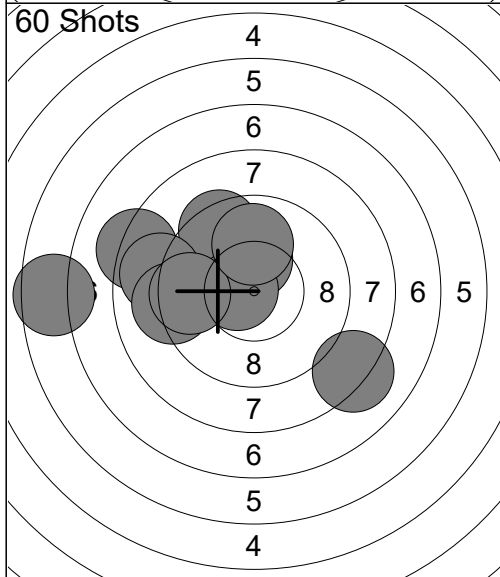

41:	10.3x	↑
42:	9.4	↗
43:	6.6	←
44:	8.2	↘
45:	8.2	←
46:	10.6x	←
47:	8.9	←
48:	9.1	←
49:	9.5	←
50:	9.9	↑
Series	90.7	
	461.2	

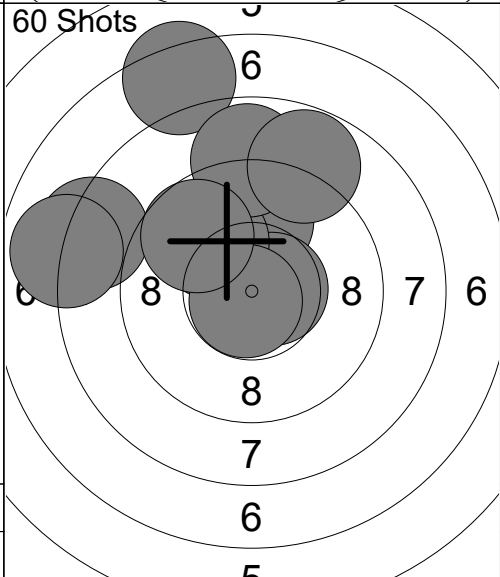

51:	7.4	↗
52:	9.8	↑
53:	10.6x	→
54:	9.9	↖
55:	8.9	↑
56:	8.2	←
57:	7.9	←
58:	8.8	↑
59:	10.8x	↘
60:	9.7	↖
Series	92.0	
	553.2	

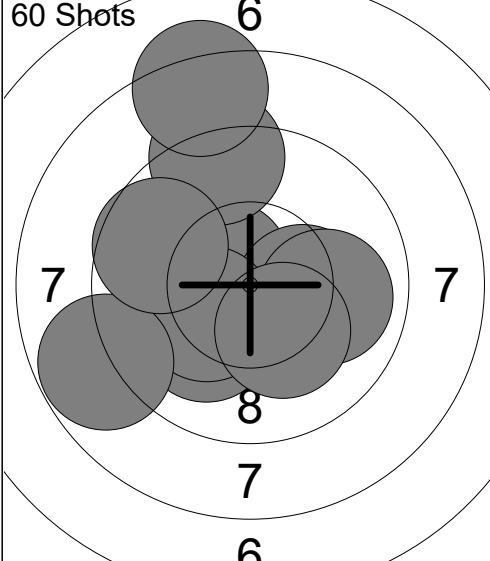
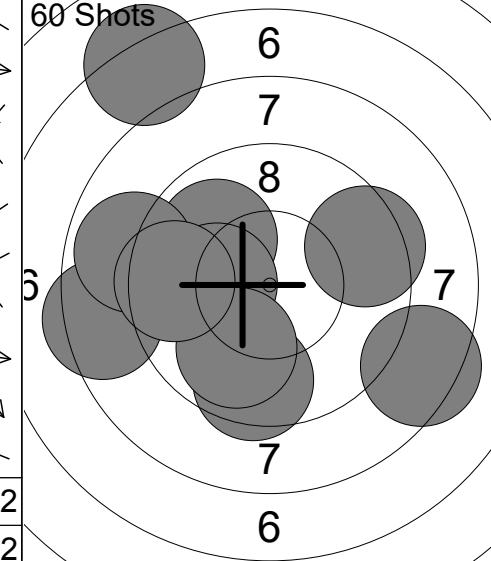
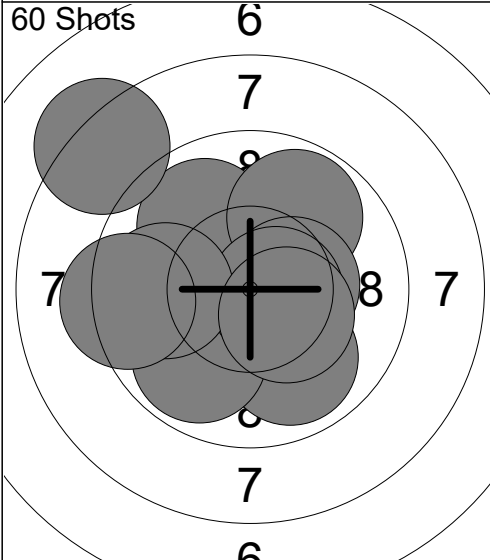
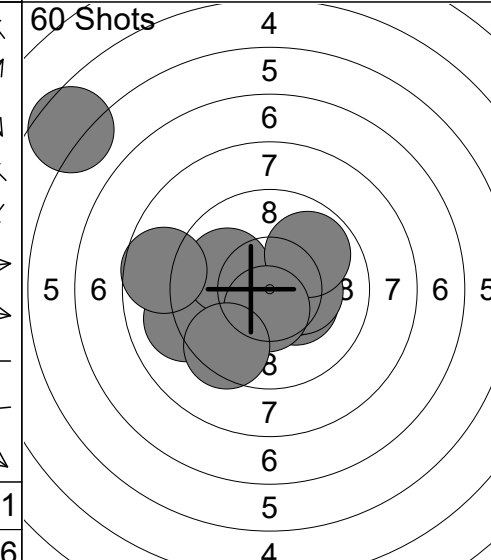
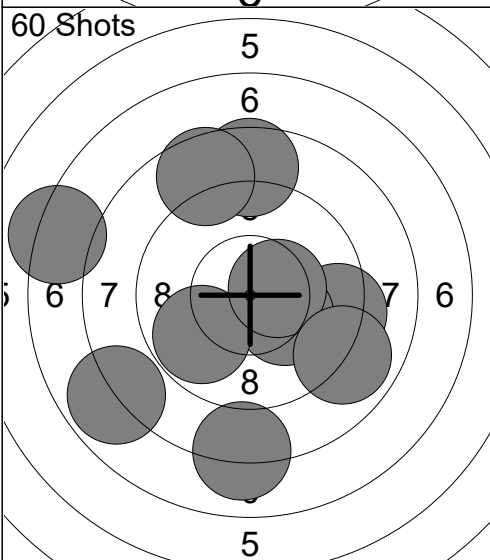
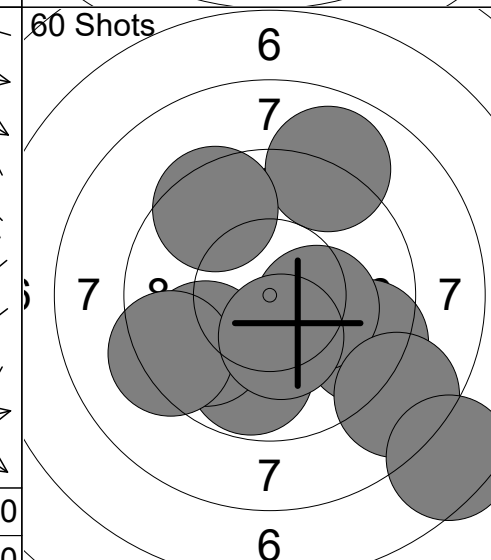
<p>60 Shots</p>  <p style="text-align: center;">6 7 7 8 7</p> <p style="text-align: center;">Series 97.2</p>	<p>1: 10.5x ↖</p> <p>2: 10.3x →</p> <p>3: 10.1 ↙</p> <p>4: 9.2 ↑</p> <p>5: 10.3x ↙</p> <p>6: 8.8 ←</p> <p>7: 8.3 ↑</p> <p>8: 9.9 →</p> <p>9: 10.2x ↘</p> <p>10: 9.6 ↖</p> <p style="text-align: center;">Series 97.2</p>	<p>60 Shots</p>  <p style="text-align: center;">6 7 8 7 6 7 7 6 7 6</p> <p style="text-align: center;">Series 91.3</p>
97.2		188.5
<p>60 Shots</p>  <p style="text-align: center;">6 7 9 7 8 7 6 7</p> <p style="text-align: center;">Series 98.1</p>	<p>21: 9.9 ↗</p> <p>22: 9.8 ↗</p> <p>23: 9.9 ↘</p> <p>24: 8.2 ↗</p> <p>25: 9.8 ↘</p> <p>26: 10.4x →</p> <p>27: 10.6x →</p> <p>28: 9.8 ←</p> <p>29: 9.3 ←</p> <p>30: 10.4x ↘</p> <p style="text-align: center;">Series 98.1</p>	<p>60 Shots</p>  <p style="text-align: center;">4 5 6 7 8 8 7 6 5 8 7 6 5</p> <p style="text-align: center;">Series 94.4</p>
286.6		381.0
<p>60 Shots</p>  <p style="text-align: center;">5 6 6 7 8 7 6 5 8 7 6 5</p> <p style="text-align: center;">Series 89.0</p>	<p>41: 7.2 ←</p> <p>42: 9.3 →</p> <p>43: 10.2x ↘</p> <p>44: 8.6 ↑</p> <p>45: 8.6 ↑</p> <p>46: 9.8 ↙</p> <p>47: 7.9 ↙</p> <p>48: 8.1 ↓</p> <p>49: 10.4x →</p> <p>50: 8.9 ↘</p> <p style="text-align: center;">Series 89.0</p>	<p>60 Shots</p>  <p style="text-align: center;">6 7 7 7 7 7 7 6 7 6</p> <p style="text-align: center;">Series 93.4</p>
470.0		563.4

Relay 3	Lane 49	FONDY Megan
-------------------	-------------------	--------------------

1-80	SIRPC Precision	Precision	
------	-----------------	-----------	--

31.01.2025	2025 AirNats by X Count	Civilian Marksmanship Program	
------------	-------------------------	-------------------------------	--

Comment	Signature		
---------	-----------	--	--

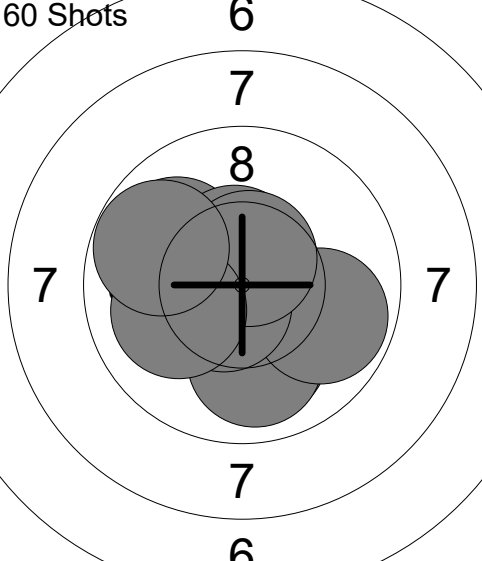
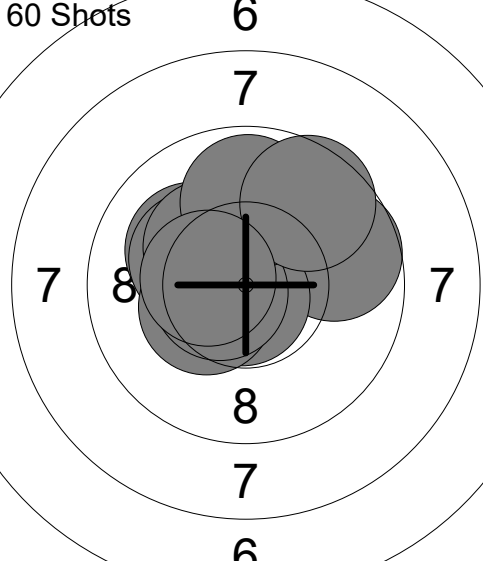
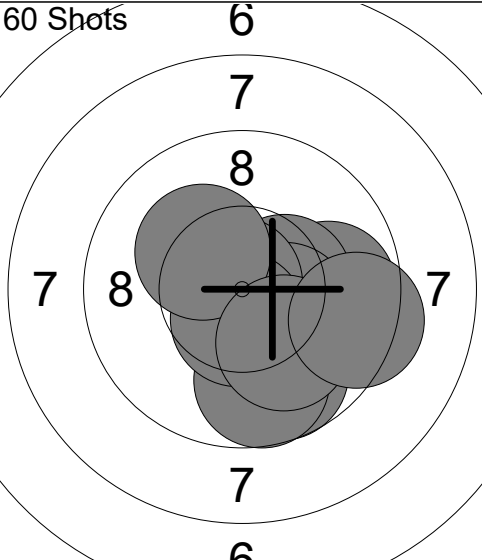
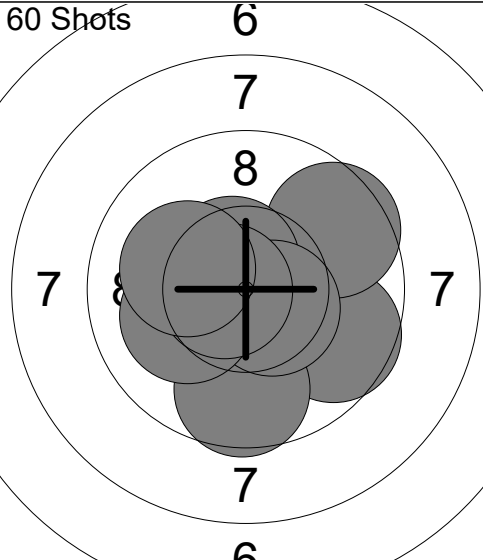
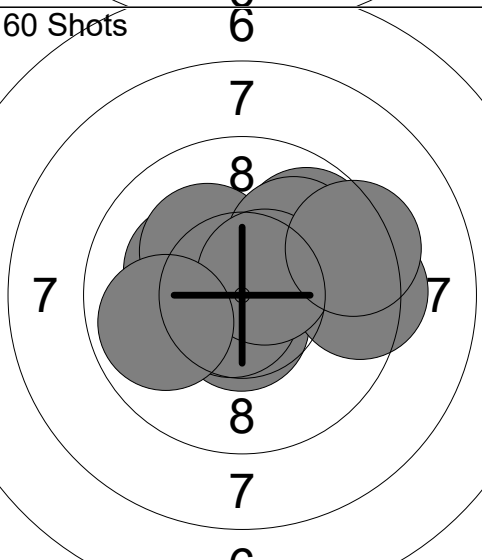
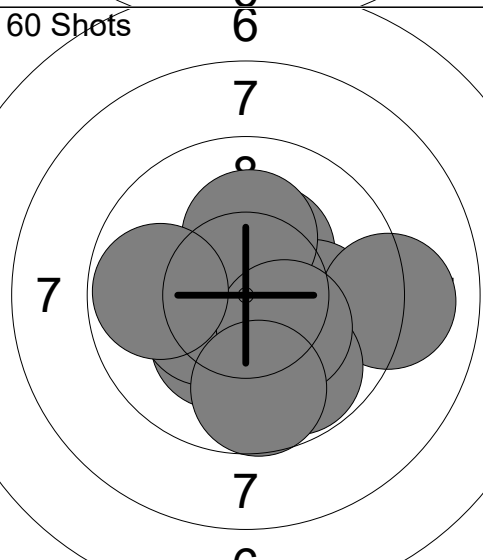
<p>60 Shots</p> 	<p>1: 10.0 ↓ 2: 10.0 ↓ 3: 9.8 → 4: 10.6x ↗ 5: 9.9 ↗ 6: 10.6x ↙ 7: 10.5x ↗ 8: 10.6x ↗ 9: 10.0 ← 10: 9.8 ↙</p> <p>Series 101.8 101.8</p>	<p>60 Shots</p> 	<p>11: 10.1 ↙ 12: 10.2x ↙ 13: 9.7 → 14: 10.8x ↓ 15: 10.4x ↙ 16: 10.3x ↙ 17: 10.6x ← 18: 9.9 ↑ 19: 9.6 ↗ 20: 10.4x ←</p> <p>Series 102.0 203.8</p>
<p>60 Shots</p> 	<p>21: 9.8 → 22: 9.7 ↓ 23: 10.4x → 24: 10.3x → 25: 9.7 ↓ 26: 10.8x ↗ 27: 10.6x ↓ 28: 10.2x ↗ 29: 10.0 ↓ 30: 9.4 →</p> <p>Series 100.9 304.7</p>	<p>60 Shots</p> 	<p>31: 10.3x ← 32: 9.6 → 33: 9.6 ↗ 34: 10.6x ↗ 35: 9.6 ↓ 36: 10.5x → 37: 10.3x ← 38: 10.1 ← 39: 10.7x ← 40: 10.1 ←</p> <p>Series 101.4 406.1</p>
<p>60 Shots</p> 	<p>41: 10.6x ↓ 42: 10.7x ↙ 43: 10.2x ↙ 44: 9.4 → 45: 10.2x ↗ 46: 9.8 ↗ 47: 10.0 ↗ 48: 10.6x ↗ 49: 9.4 → 50: 9.9 ←</p> <p>Series 100.8 506.9</p>	<p>60 Shots</p> 	<p>51: 10.2x ↙ 52: 10.3x ↗ 53: 10.1 → 54: 9.1 → 55: 10.4x ↙ 56: 9.8 ↓ 57: 10.2x ↑ 58: 10.3x → 59: 9.7 ↓ 60: 9.8 ←</p> <p>Series 99.9 606.8</p>

Relay **3** Lane **50** **LYONS Ian**

1-80 Individual Precision

31.01.2025 2025 AirNats by X Count Civilian Marksmanship Program

Comment Signature

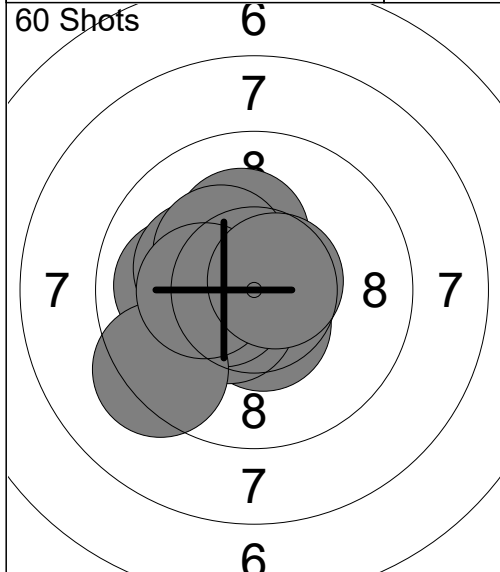

1:	10.0	←
2:	10.5x	↓
3:	10.2x	↑
4:	10.5x	↙
5:	10.5x	←
6:	9.3	↙
7:	10.2x	↖
8:	10.3x	↗
9:	10.3x	←
10:	10.6x	→
Series	102.4	
	102.4	

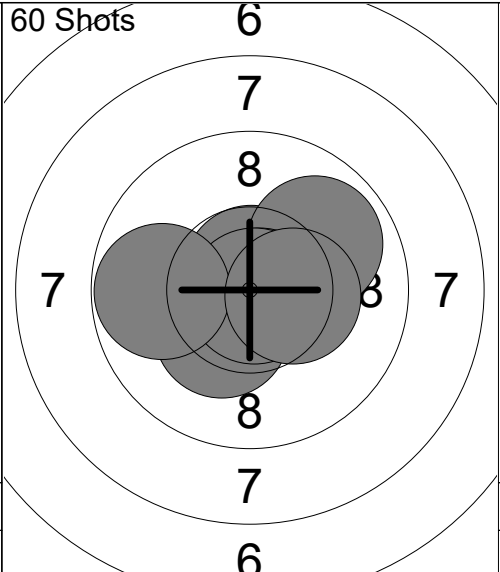

11:	10.7x	↗
12:	10.7x	→
13:	10.7x	↑
14:	9.9	↗
15:	10.5x	↙
16:	10.8x	⇒
17:	10.3x	↙
18:	10.8x	↘
19:	9.8	←
20:	10.4x	→
Series	104.6	
	207.0	

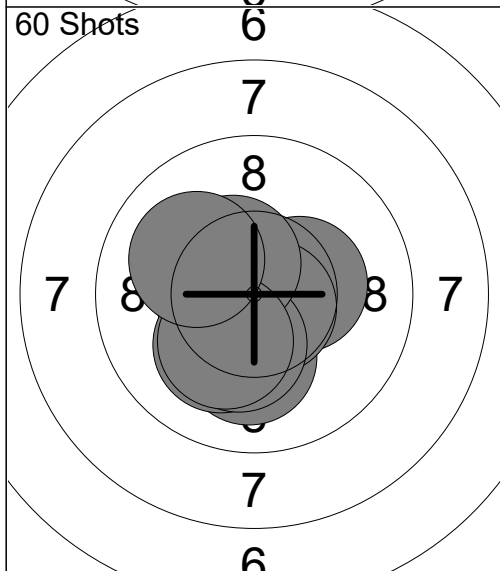

21:	10.1	↓
22:	10.5x	↖
23:	10.4x	↙
24:	10.1	↙
25:	10.3x	→
26:	10.7x	↘
27:	10.3x	↓
28:	10.5x	↗
29:	10.2x	↙
30:	10.1	↖
Series	103.2	
	310.2	

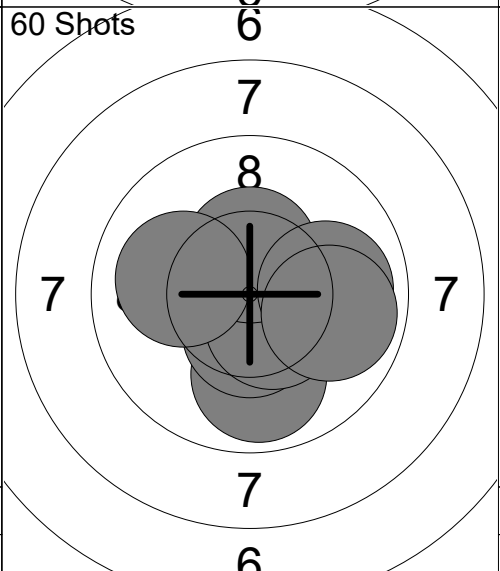

31:	10.8x	⇒
32:	10.5x	↑
33:	10.7x	→
34:	9.9	↓
35:	10.5x	↓
36:	10.5x	↘
37:	10.4x	↑
38:	9.9	→
39:	9.9	⇒
40:	10.1	←
Series	103.2	
	413.4	

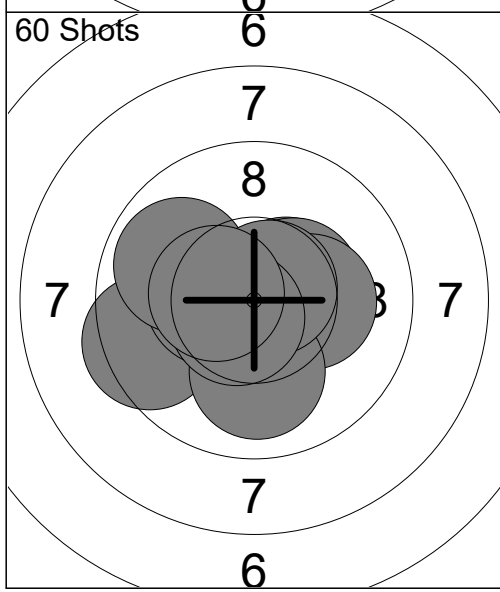

41:	9.5	←
42:	10.5x	↗
43:	10.4x	←
44:	10.4x	→
45:	9.9	↖
46:	10.2x	→
47:	10.0	↓
48:	10.7x	↗
49:	10.6x	↙
50:	10.4x	←
Series	102.6	
	516.0	

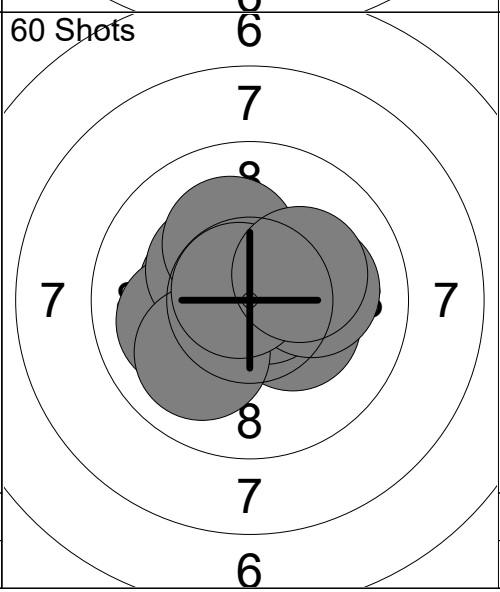

51:	10.4x	↖
52:	10.3x	⇒
53:	10.8x	→
54:	10.0	←
55:	10.3x	↖
56:	10.2x	↑
57:	10.0	↙
58:	10.1	→
59:	10.8x	↖
60:	10.2x	↗
Series	103.1	
	619.1	

<p>60 Shots</p>	<p>1: 10.6x ↗ 2: 10.6x ↑ 3: 10.2x ➡ 4: 10.4x ↙ 5: 9.7 ↑ 6: 9.9 ➡ 7: 10.3x ↖ 8: 10.4x ↑ 9: 10.1 ➡ 10: 10.4x ↑</p> <p>Series 102.6</p>	<p>60 Shots</p>	<p>11: 9.6 ↙ 12: 10.2x ↗ 13: 9.8 ➡ 14: 10.6x ➡ 15: 9.3 ➡ 16: 10.8x ↖ 17: 10.4x ↗ 18: 10.5x ↖ 19: 10.5x ↘ 20: 10.7x ↑</p> <p>Series 102.4</p>
6	102.6	6	205.0
<p>60 Shots</p>	<p>21: 10.0 ➡ 22: 10.3x ➡ 23: 10.4x ➡ 24: 10.2x ↓ 25: 9.8 ↖ 26: 9.8 ↙ 27: 10.6x ↘ 28: 10.7x ➡ 29: 10.1 ↖ 30: 10.1 ↑</p> <p>Series 102.0</p>	<p>60 Shots</p>	<p>31: 9.7 ➡ 32: 10.7x ↖ 33: 10.7x ➡ 34: 10.2x ➡ 35: 10.4x ↓ 36: 10.2x ↖ 37: 10.7x ↖ 38: 10.5x ➡ 39: 10.4x ➡ 40: 10.2x ↓</p> <p>Series 103.7</p>
6	307.0	6	410.7
<p>60 Shots</p>	<p>41: 9.4 ➡ 42: 10.4x ➡ 43: 10.1 ↖ 44: 10.0 ↙ 45: 10.4x ➡ 46: 10.0 ↖ 47: 10.4x ↗ 48: 10.2x ↘ 49: 10.2x ↑ 50: 10.6x ↗</p> <p>Series 101.7</p>	<p>60 Shots</p>	<p>51: 9.8 ↖ 52: 10.6x ↗ 53: 9.5 ➡ 54: 10.5x ↗ 55: 9.4 ↙ 56: 9.8 ↖ 57: 9.8 ↗ 58: 9.7 ↖ 59: 9.4 ↖ 60: 10.4x ↑</p> <p>Series 98.9</p>
6	512.4	6	611.3

<p>60 Shots</p>	<p>1: 10.1 ↘ 2: 9.9 ↗ 3: 10.0 ↘ 4: 10.2x → 5: 10.3x ↓ 6: 10.0 ↘ 7: 9.6 ← 8: 10.5x ↗ 9: 10.6x ↗ 10: 10.3x ↗</p> <p>Series 101.5</p>	<p>60 Shots</p>	<p>11: 10.6x ↗ 12: 9.8 ↗ 13: 10.2x → 14: 10.1 → 15: 10.4x ↖ 16: 10.5x ← 17: 10.6x ↓ 18: 9.8 ↗ 19: 10.3x ↘ 20: 10.9x ↓</p> <p>Series 103.2</p>
	101.5		204.7
<p>60 Shots</p>	<p>21: 10.5x → 22: 10.3x ← 23: 9.8 ↘ 24: 10.4x ↘ 25: 10.5x ↓ 26: 10.6x ↓ 27: 10.1 ← 28: 9.9 ↗ 29: 10.5x ↖ 30: 9.9 ↗</p> <p>Series 102.5</p>	<p>60 Shots</p>	<p>31: 10.8x ↗ 32: 10.8x ↖ 33: 10.9x ← 34: 10.7x ↖ 35: 9.7 ↗ 36: 10.6x → 37: 10.5x ↗ 38: 10.1 → 39: 10.6x ↘ 40: 10.2x →</p> <p>Series 104.9</p>
	307.2		412.1
<p>60 Shots</p>	<p>41: 10.4x ↗ 42: 10.8x ↖ 43: 9.4 ↘ 44: 9.9 ↗ 45: 10.2x → 46: 10.3x ← 47: 10.3x ↖ 48: 10.1 ↖ 49: 9.4 ↗ 50: 10.2x →</p> <p>Series 101.0</p>	<p>60 Shots</p>	<p>51: 10.4x ↖ 52: 10.0 ↗ 53: 9.7 ← 54: 9.0 ↘ 55: 10.4x ↗ 56: 9.7 ↗ 57: 10.4x ↖ 58: 10.3x → 59: 10.0 → 60: 9.8 ↗</p> <p>Series 99.7</p>
	513.1		612.8

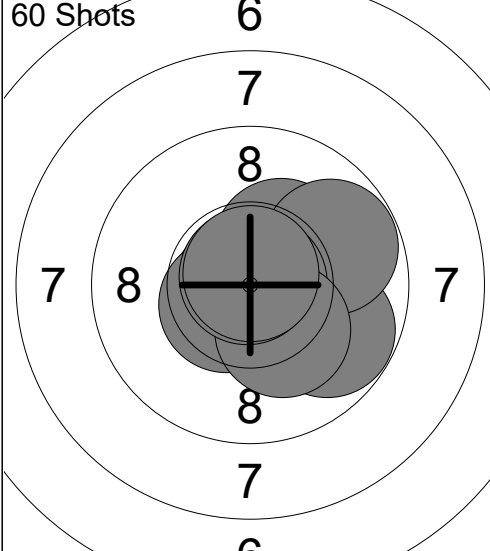
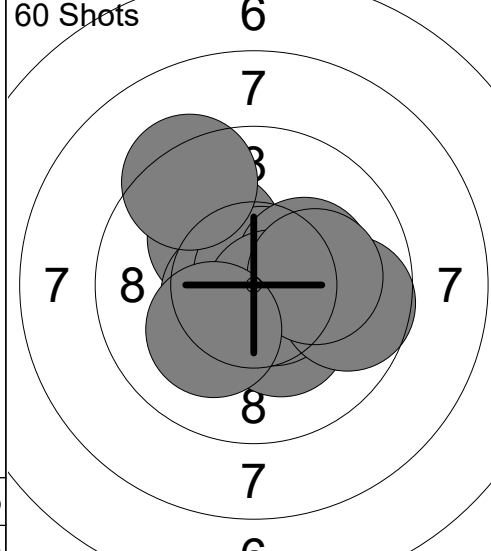
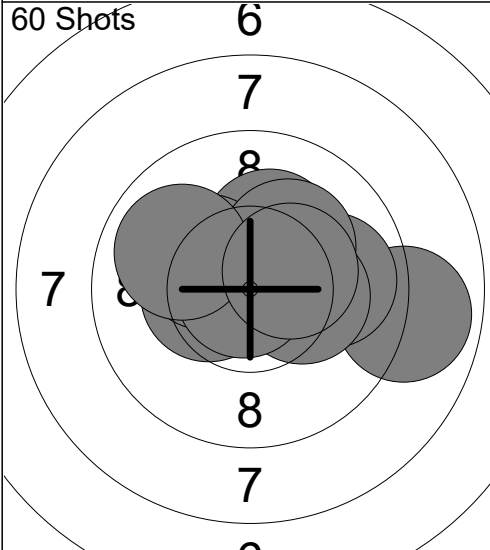
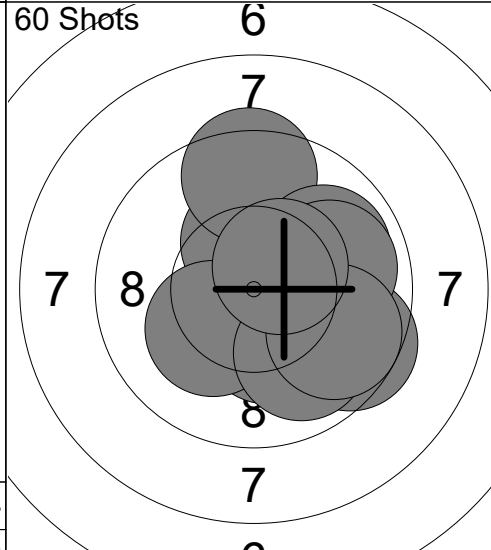
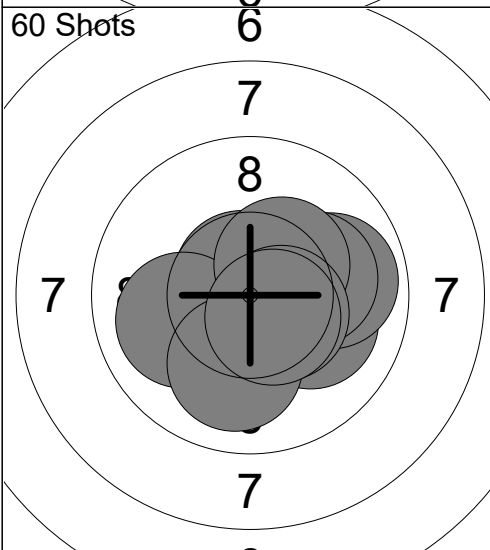
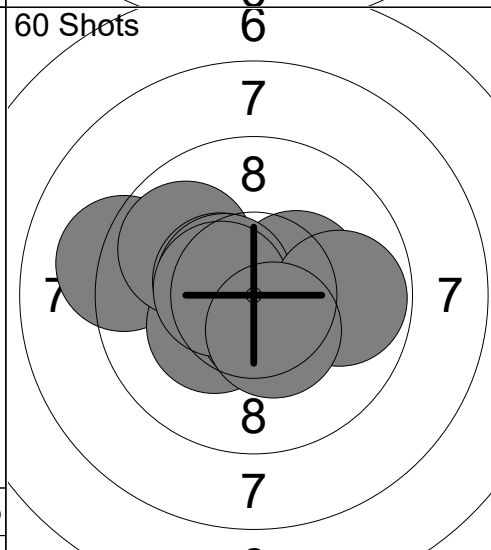
<p>60 Shots</p>  <p style="text-align: center;">6 7 8 7 8 7</p>	<p>1: 9.8 ➤</p> <p>2: 10.7x ↓</p> <p>3: 10.3x ↗</p> <p>4: 10.8x ←</p> <p>5: 10.5x ↙</p> <p>6: 9.8 ➔</p> <p>7: 10.8x ➔</p> <p>8: 10.2x ↘</p> <p>9: 10.8x ↗</p> <p>10: 10.8x ↑</p> <hr/> <p>Series 104.5</p> <p style="text-align: center;">104.5</p>	<p>60 Shots</p>  <p style="text-align: center;">6 7 8 7 8 7</p>	<p>11: 10.1 ↖</p> <p>12: 10.6x ←</p> <p>13: 10.3x ↘</p> <p>14: 10.8x ↗</p> <p>15: 10.2x ➔</p> <p>16: 10.7x ↘</p> <p>17: 9.7 ➔</p> <p>18: 10.1 ➔</p> <p>19: 9.4 ↗</p> <p>20: 10.2x ↙</p> <hr/> <p>Series 102.1</p> <p style="text-align: center;">206.6</p>
<p>60 Shots</p>  <p style="text-align: center;">6 7 8 7 8 7</p>	<p>21: 10.2x ↑</p> <p>22: 10.4x ←</p> <p>23: 8.9 ➔</p> <p>24: 10.3x ↖</p> <p>25: 9.9 ➔</p> <p>26: 10.2x ↗</p> <p>27: 10.3x ➔</p> <p>28: 10.9x ←</p> <p>29: 9.9 ↖</p> <p>30: 10.4x ➔</p> <hr/> <p>Series 101.4</p> <p style="text-align: center;">308.0</p>	<p>60 Shots</p>  <p style="text-align: center;">6 7 8 7 8 7</p>	<p>31: 10.3x ↑</p> <p>32: 10.3x ↘</p> <p>33: 9.5 ➔</p> <p>34: 10.2x ↙</p> <p>35: 9.9 ↘</p> <p>36: 9.4 ↑</p> <p>37: 9.9 ➔</p> <p>38: 9.9 ➔</p> <p>39: 9.8 ➔</p> <p>40: 10.5x ↗</p> <hr/> <p>Series 99.7</p> <p style="text-align: center;">407.7</p>
<p>60 Shots</p>  <p style="text-align: center;">6 7 8 7 8 7 6</p>	<p>41: 10.7x ↗</p> <p>42: 10.3x ➔</p> <p>43: 10.1 ➔</p> <p>44: 9.9 ➔</p> <p>45: 10.0 ←</p> <p>46: 10.1 ➔</p> <p>47: 10.0 ↓</p> <p>48: 10.4x ↗</p> <p>49: 10.5x ↘</p> <p>50: 10.5x ↘</p> <hr/> <p>Series 102.5</p> <p style="text-align: center;">510.2</p>	<p>60 Shots</p>  <p style="text-align: center;">6 7 8 7 8 7 6</p>	<p>51: 9.2 ←</p> <p>52: 10.3x ↙</p> <p>53: 10.3x ➔</p> <p>54: 9.9 ↖</p> <p>55: 10.5x ←</p> <p>56: 10.6x ↘</p> <p>57: 10.5x ↖</p> <p>58: 10.5x ←</p> <p>59: 9.8 ➔</p> <p>60: 10.4x ↘</p> <hr/> <p>Series 102.0</p> <p style="text-align: center;">612.2</p>

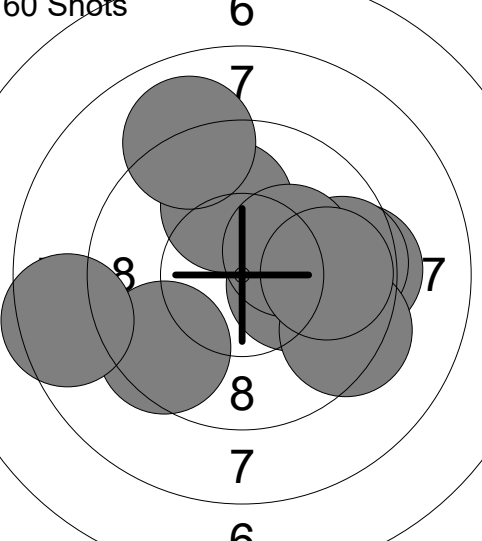
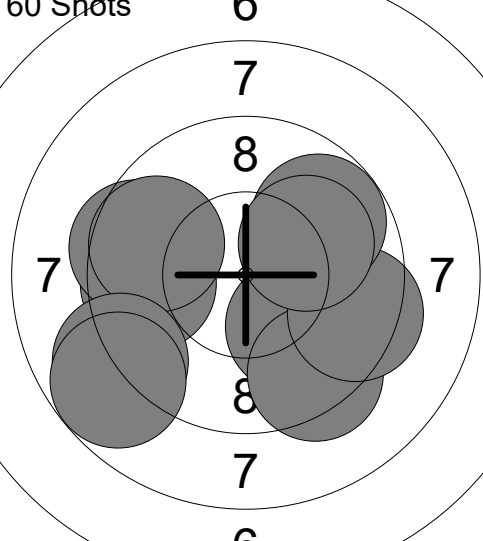
<p>60 Shots</p> 	<p>1: 10.3x →</p> <p>2: 9.4 →</p> <p>3: 9.6 →</p> <p>4: 10.0 ↑</p> <p>5: 9.5 ↙</p> <p>6: 9.0 ↑</p> <p>7: 8.5 ←</p> <p>8: 10.2x ↗</p> <p>9: 9.4 ⇒</p> <p>10: 9.8 →</p> <hr/> <p>Series 95.7</p> <p style="text-align: right;">95.7</p>	<p>60 Shots</p> 	<p>11: 10.0 ↘</p> <p>12: 9.4 ↘</p> <p>13: 9.7 ←</p> <p>14: 9.5 ←</p> <p>15: 9.4 ⇒</p> <p>16: 9.7 ←</p> <p>17: 8.9 ↙</p> <p>18: 9.8 ↗</p> <p>19: 8.8 ↙</p> <p>20: 10.0 ↗</p> <hr/> <p>Series 95.2</p> <p style="text-align: right;">190.9</p>
--	---	--	--

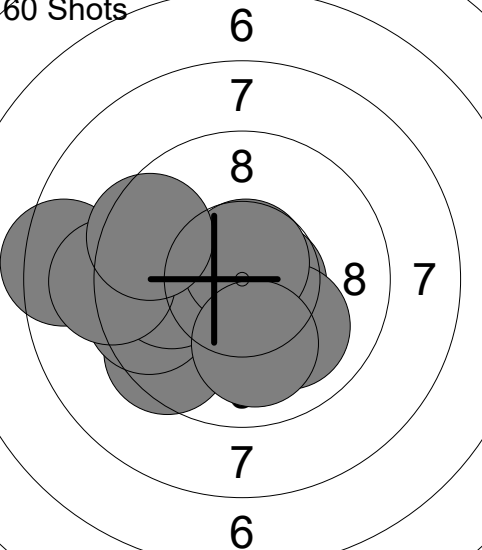
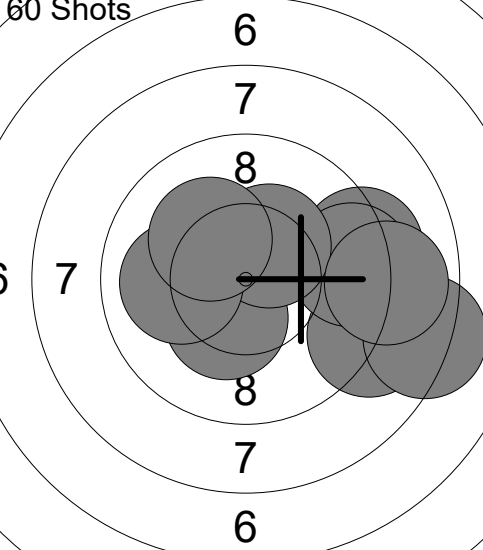
<p>60 Shots</p> 	<p>21: 9.5 ↙</p> <p>22: 9.6 ←</p> <p>23: 10.6x ⇒</p> <p>24: 8.4 ←</p> <p>25: 9.9 ←</p> <p>26: 9.1 ←</p> <p>27: 10.0 ↘</p> <p>28: 10.7x ↑</p> <p>29: 10.0 ↘</p> <p>30: 9.5 ←</p> <hr/> <p>Series 97.3</p> <p style="text-align: right;">288.2</p>	<p>60 Shots</p> 	<p>31: 9.0 ⇒</p> <p>32: 8.2 ⇒</p> <p>33: 10.5x ↑</p> <p>34: 10.3x ↘</p> <p>35: 9.2 ⇒</p> <p>36: 9.4 ⇒</p> <p>37: 10.4x ↑</p> <p>38: 8.9 ⇒</p> <p>39: 10.0 ←</p> <p>40: 10.2x ↖</p> <hr/> <p>Series 96.1</p> <p style="text-align: right;">384.3</p>
---	--	---	---

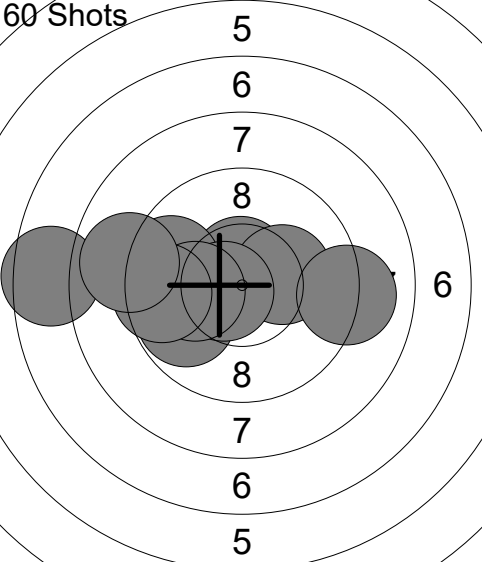
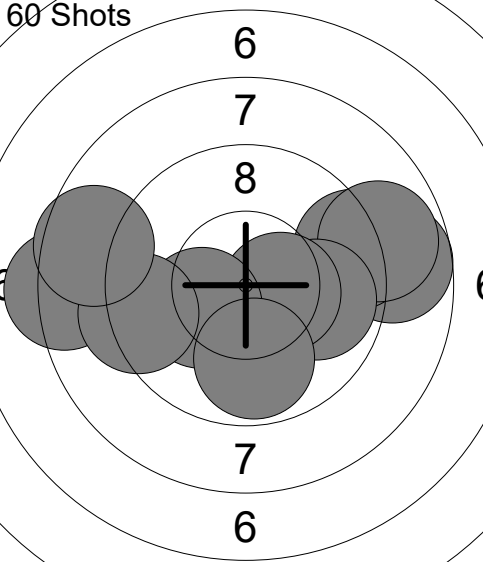
<p>60 Shots</p> 	<p>41: 10.6x ↑</p> <p>42: 9.8 ←</p> <p>43: 7.5 ←</p> <p>44: 10.2x ⇒</p> <p>45: 9.6 ←</p> <p>46: 10.6x ←</p> <p>47: 9.1 ⇒</p> <p>48: 10.1 ←</p> <p>49: 9.5 ←</p> <p>50: 8.9 ←</p> <hr/> <p>Series 95.9</p> <p style="text-align: right;">480.2</p>	<p>60 Shots</p> 	<p>51: 8.7 ⇒</p> <p>52: 9.3 ⇒</p> <p>53: 8.9 ⇒</p> <p>54: 9.9 ⇒</p> <p>55: 8.2 ←</p> <p>56: 10.4x ⇒</p> <p>57: 10.2x ↙</p> <p>58: 9.8 ↘</p> <p>59: 9.3 ←</p> <p>60: 8.6 ←</p> <hr/> <p>Series 93.3</p> <p style="text-align: right;">573.5</p>
--	---	--	--

Relay 3	Lane 56	ZHOU Angel Jiajia
-------------------	-------------------	--------------------------

1-80	Culver Academy	Precision	
------	----------------	-----------	--

31.01.2025	2025 AirNats by X Count	Civilian Marksmanship Program	
------------	-------------------------	-------------------------------	--

Comment	Signature		
---------	-----------	--	--

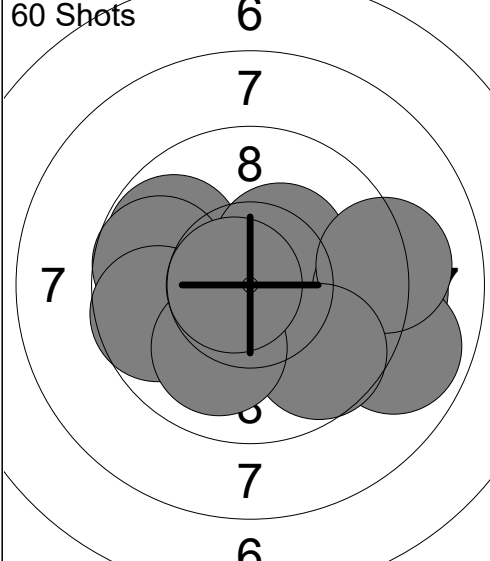
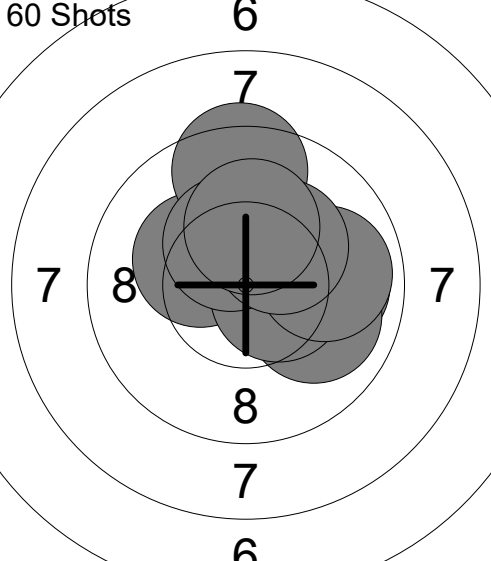
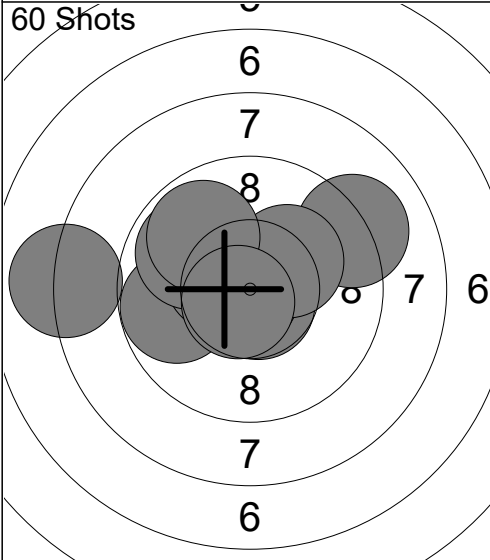
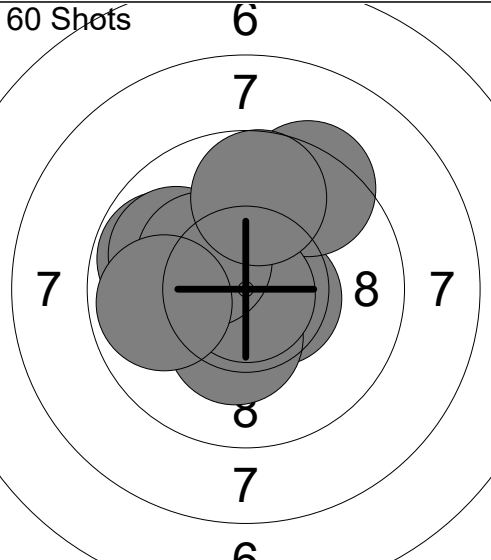
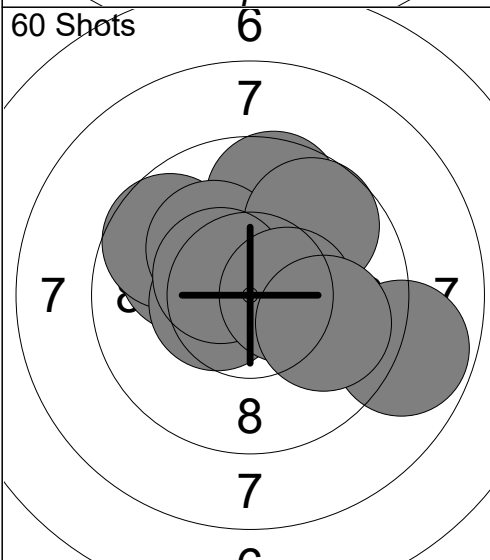
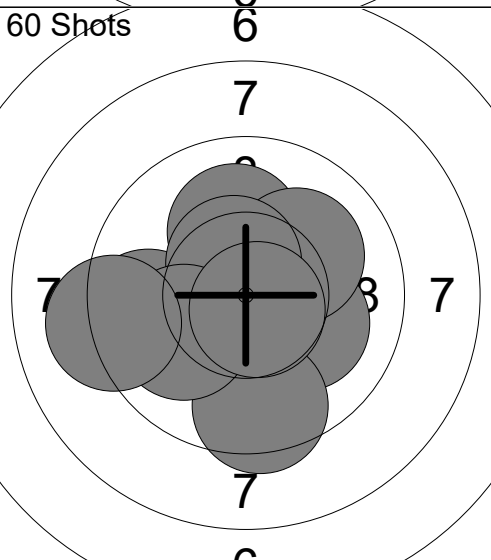
<p>60 Shots</p> 	<p>1: 9.8 ↖ 2: 9.7 ↖ 3: 9.7 ↖ 4: 10.3x ↗ 5: 9.2 → 6: 8.9 → 7: 9.2 → 8: 9.7 ↘ 9: 10.0 ↘ 10: 10.7x ←</p> <p>Series 97.2 97.2</p>	<p>60 Shots</p> 	<p>11: 10.3x → 12: 9.9 → 13: 10.3x ↖ 14: 10.0 → 15: 10.5x → 16: 9.4 ↑ 17: 10.4x ↑ 18: 9.9 → 19: 10.3x ↗ 20: 10.2x ↑</p> <p>Series 101.2 198.4</p>
<p>60 Shots</p> 	<p>21: 10.7x ↘ 22: 9.1 ↗ 23: 10.8x ↖ 24: 9.8 ↖ 25: 10.5x ↖ 26: 8.0 ← 27: 9.9 ↖ 28: 10.2x ↗ 29: 9.8 ↗ 30: 10.7x ↘</p> <p>Series 99.5 297.9</p>	<p>60 Shots</p> 	<p>31: 10.3x ↑ 32: 9.8 ↖ 33: 10.6x → 34: 9.9 ↖ 35: 9.4 ↗ 36: 10.3x ↘ 37: 10.9x ↘ 38: 10.3x ↖ 39: 9.9 ← 40: 9.7 ↑</p> <p>Series 101.1 399.0</p>
<p>60 Shots</p> 	<p>41: 10.0 ↖ 42: 9.7 ↖ 43: 9.6 ↑ 44: 10.2x ↗ 45: 10.5x ← 46: 9.7 ↗ 47: 10.5x ↖ 48: 8.8 → 49: 10.5x → 50: 9.9 →</p> <p>Series 99.4 498.4</p>	<p>60 Shots</p> 	<p>51: 10.1 ↑ 52: 10.3x ↘ 53: 10.1 → 54: 10.1 ↗ 55: 9.6 ← 56: 9.5 ↘ 57: 10.5x ↑ 58: 10.0 ↖ 59: 9.2 ← 60: 10.7x ↘</p> <p>Series 100.1 598.5</p>

<p>60 Shots</p> <p style="text-align: center;">6 7 7 7 8 7 6</p>	<p>1: 9.2 ←</p> <p>2: 10.3x ↗</p> <p>3: 9.2 ←</p> <p>4: 10.1 →</p> <p>5: 8.7 ↗</p> <p>6: 9.9 ↗</p> <p>7: 9.6 ↗</p> <p>8: 9.0 →</p> <p>9: 10.7x ↗</p> <p>10: 9.3 ↗</p> <hr/> <p>Series 96.0</p> <p style="text-align: right;">96.0</p>	<p>60 Shots</p> <p style="text-align: center;">5 6 7 6 7 7 6 6 8 7 6 5</p>	<p>11: 7.7 ↗</p> <p>12: 10.0 →</p> <p>13: 10.0 ↗</p> <p>14: 10.4x ↗</p> <p>15: 8.7 ↗</p> <p>16: 9.3 ↙</p> <p>17: 10.0 →</p> <p>18: 9.0 ←</p> <p>19: 7.3 →</p> <p>20: 9.4 ↑</p> <hr/> <p>Series 91.8</p> <p style="text-align: right;">187.8</p>
--	---	--	---

<p>60 Shots</p> <p style="text-align: center;">5 6 7 6 5 6 7 6 5 8 7 6 6</p>	<p>21: 8.9 →</p> <p>22: 8.2 →</p> <p>23: 9.1 ←</p> <p>24: 10.7x ↙</p> <p>25: 9.9 ↗</p> <p>26: 8.6 ↗</p> <p>27: 6.5 ↓</p> <p>28: 7.3 ↓</p> <p>29: 9.1 →</p> <p>30: 7.9 ↘</p> <hr/> <p>Series 86.2</p> <p style="text-align: right;">274.0</p>	<p>60 Shots</p> <p style="text-align: center;">4 5 6 7 6 7 6 5 6 7 6 5 8 7 6 5</p>	<p>31: 8.2 ↗</p> <p>32: 8.4 →</p> <p>33: 9.2 ←</p> <p>34: 9.6 ←</p> <p>35: 8.8 ↗</p> <p>36: 6.5 ←</p> <p>37: 9.7 →</p> <p>38: 8.1 ↘</p> <p>39: 9.8 →</p> <p>40: 8.9 ↗</p> <hr/> <p>Series 87.2</p> <p style="text-align: right;">361.2</p>
--	--	--	--

<p>60 Shots</p> <p style="text-align: center;">5 6 7 8 6 7 6 8 7 6 8 7 6 8 7 6 5</p>	<p>41: 7.7 →</p> <hr/> <p>Series 7.7</p> <p style="text-align: right;">368.9</p>		
--	--	--	--

Relay 3	Lane 58	SHI Samuel Zhenhe
--------------------------	--------------------------	--------------------------

1-80	Culver Academy	Precision	
------	----------------	-----------	--

31.01.2025	2025 AirNats by X Count	Civilian Marksmanship Program	
------------	-------------------------	-------------------------------	--

Comment	Signature		
---------	-----------	--	--

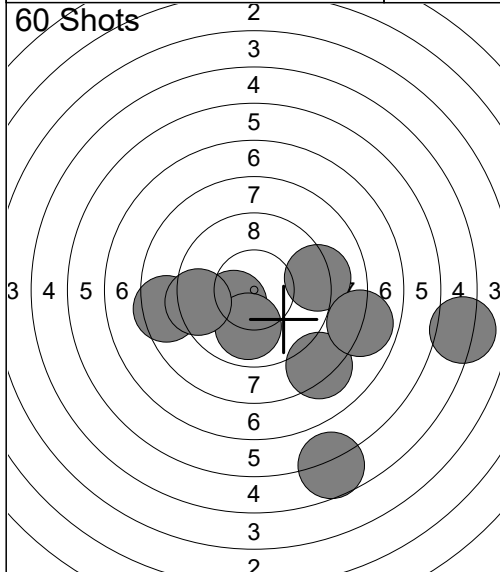

1:	9.2	→
2:	5.1	→
3:	5.7	↓
4:	0.0	
5:	10.3x	↙
6:	8.2	↘
7:	7.9	→
8:	8.5	←
9:	9.9	↓
10:	9.4	←
Series		74.2
		74.2

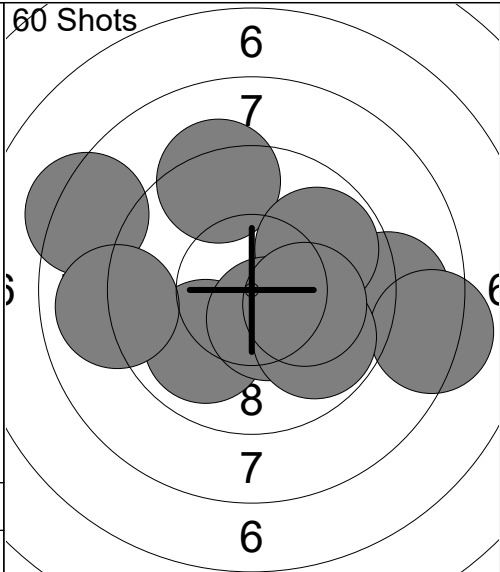

11:	10.0	↘
12:	8.3	↖
13:	9.0	→
14:	9.3	↑
15:	9.8	↗
16:	8.3	→
17:	10.5x	↘
18:	9.8	↘
19:	10.2x	→
20:	9.0	←
Series		94.2
		168.4

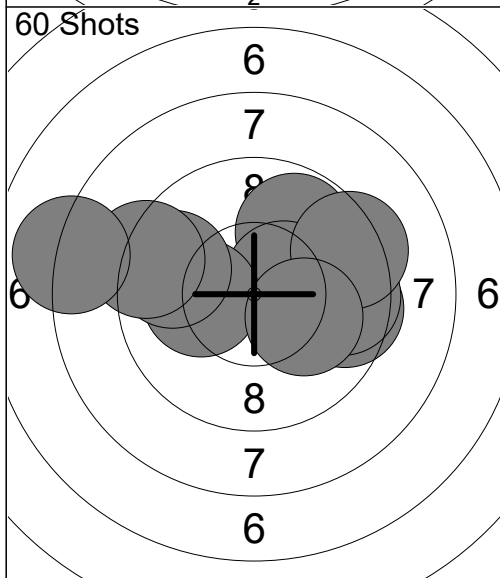

21:	9.5	→
22:	9.8	↗
23:	10.5x	↗
24:	9.6	→
25:	10.1	←
26:	9.3	↗
27:	10.1	→
28:	9.6	←
29:	9.2	←
30:	8.1	←
Series		95.8
		264.2

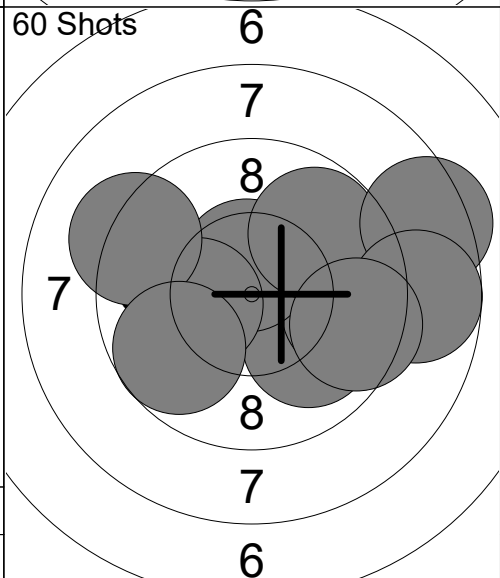

31:	10.0	↘
32:	9.6	→
33:	10.6x	↑
34:	9.8	↗
35:	8.4	↗
36:	10.2x	←
37:	8.7	→
38:	9.2	←
39:	9.5	→
40:	9.7	↙
Series		95.7
		359.9

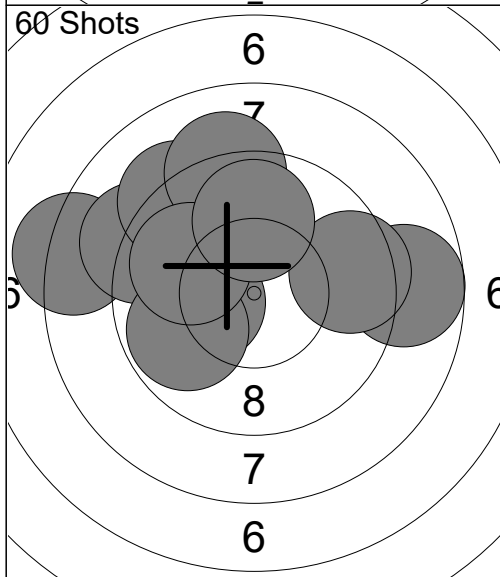

41:	8.2	←
42:	9.1	↖
43:	9.2	↗
44:	10.2x	←
45:	9.8	←
46:	8.7	→
47:	9.5	→
48:	9.1	↑
49:	9.9	↖
50:	9.9	↑
Series		93.6
		453.5

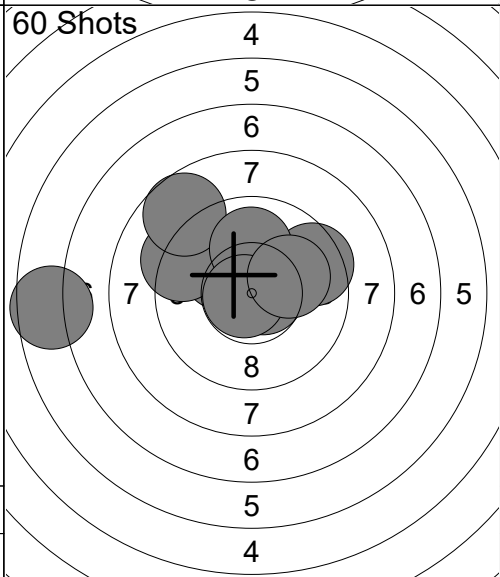

51:	10.1	↖
52:	9.3	↖
53:	8.7	↖
54:	6.6	←
55:	10.4x	↑
56:	9.5	↗
57:	10.7x	→
58:	10.0	↑
59:	10.8x	←
60:	10.1	↗
Series		96.2
		549.7

Relay 3	Lane 59	LI Leon Leyao
-------------------	-------------------	----------------------

1-80	Culver Academy	Precision	
------	----------------	-----------	--

31.01.2025	2025 AirNats by X Count	Civilian Marksmanship Program	
------------	-------------------------	-------------------------------	--

Comment	Signature		
---------	-----------	--	--

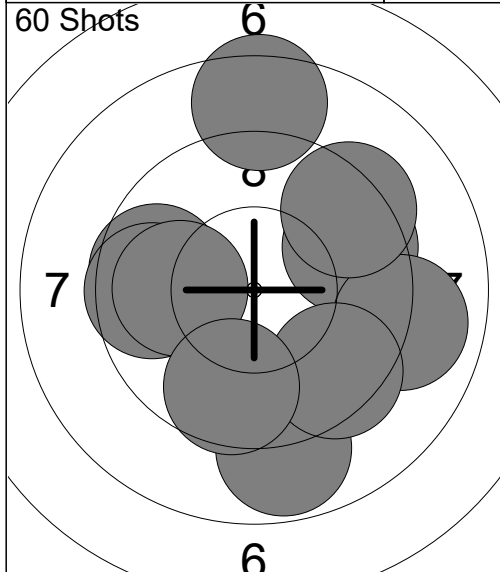

1:	8.5	↑
2:	9.6	←
3:	8.8	↓
4:	9.6	→
5:	9.0	→
6:	9.4	↘
7:	9.6	←
8:	9.3	↗
9:	10.0	←
10:	9.6	↓
Series		93.4
		93.4

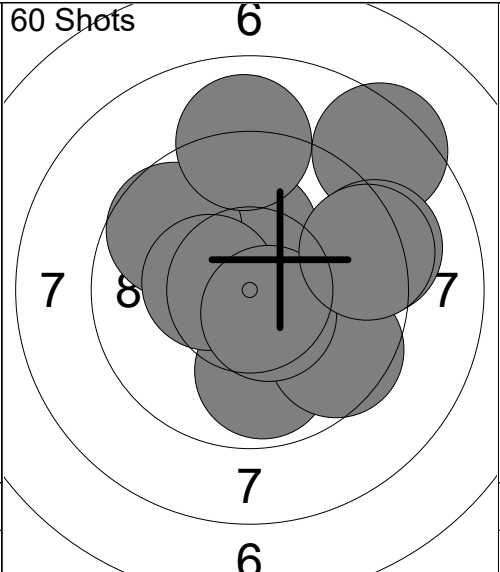

11:	10.2x	↑
12:	9.9	↓
13:	9.7	↖
14:	8.4	↗
15:	10.4x	←
16:	9.6	↘
17:	10.5x	↓
18:	9.2	→
19:	9.3	→
20:	9.0	↑
Series		96.2
		189.6

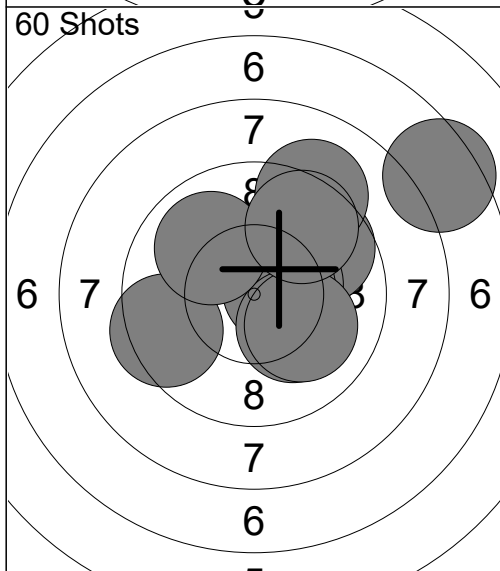

21:	9.7	↗
22:	10.4x	→
23:	10.5x	→
24:	9.1	↗
25:	10.2x	↘
26:	9.4	←
27:	10.0	↗
28:	7.5	↗
29:	10.1	↘
30:	9.6	↗
Series		96.5
		286.1

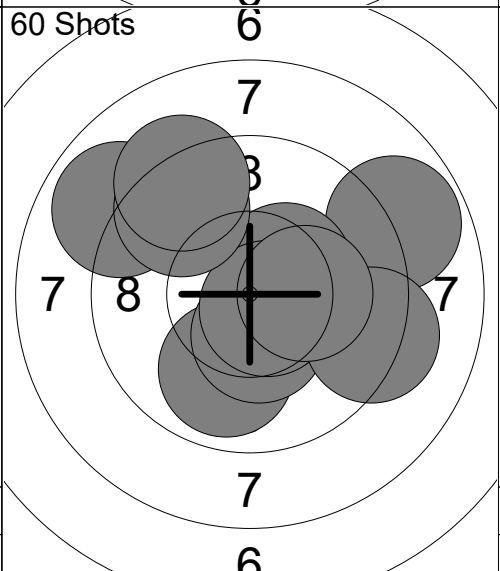

31:	8.9	↖
32:	9.9	↓
33:	8.8	→
34:	10.4x	↗
35:	10.4x	↓
36:	10.6x	↘
37:	9.5	↗
38:	9.2	↗
39:	9.3	→
40:	10.2x	→
Series		97.2
		383.3

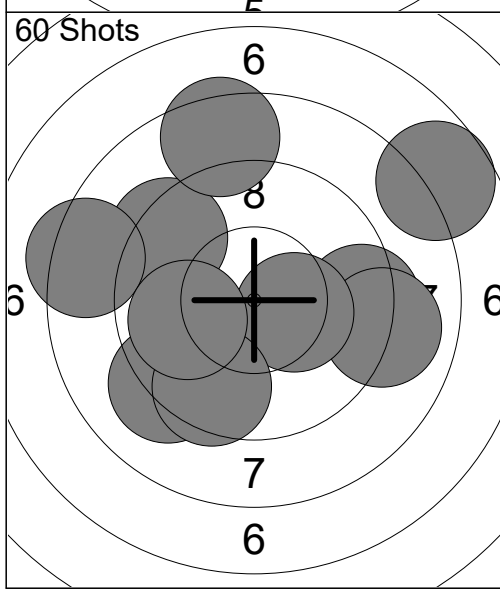

41:	9.2	↖
42:	9.4	↖
43:	9.3	→
44:	8.4	←
45:	8.4	↑
46:	9.0	→
47:	10.3x	→
48:	7.7	↗
49:	9.5	↓
50:	9.9	←
Series		91.1
		474.4

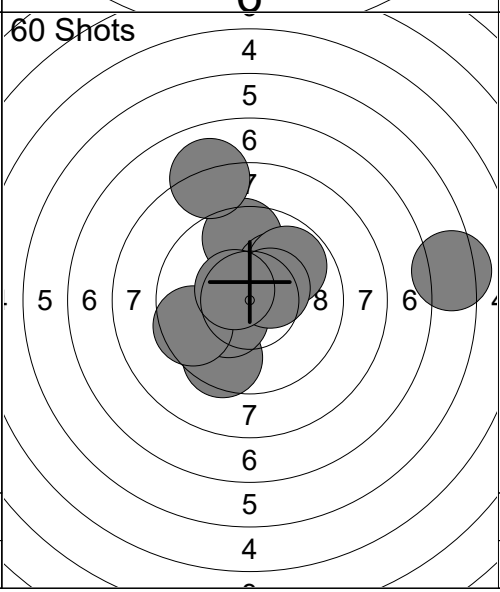

51:	9.5	↓
52:	9.5	↑
53:	10.3x	↖
54:	10.1	↗
55:	8.1	↑
56:	6.4	→
57:	9.8	↗
58:	10.4x	↗
59:	9.5	←
60:	10.5x	↖
Series		94.1
		568.5

60 Shots 	1: 8.4 ↓ 2: 10.2 → 3: 9.5 ↑ 4: 9.1 ↖ 5: 10.4x ↗ 6: 5.8 ← 7: 10.0 ↓ 8: 8.5 ← 9: 9.2 ↓ 10: 9.1 ←	60 Shots 	11: 8.5 ↙ 12: 10.3 → 13: 9.8 ← 14: 9.6 ↘ 15: 9.6 ↘ 16: 9.7 → 17: 10.4x → 18: 9.4 ← 19: 9.1 ← 20: 8.7 ↓
	Series 87 (1x)		Series 90 (1x)
	87 (1x)		177 (2x)

60 Shots 	21: 8.9 ↗ 22: 9.9 ↑ 23: 10.4x ↘ 24: 8.9 ← 25: 9.7 → 26: 8.5 ↓ 27: 10.5x ↑ 28: 8.4 ↓ 29: 8.9 ↓ 30: 9.0 ↓	60 Shots 	31: 9.8 ← 32: 10.1 ↓ 33: 9.3 ↑ 34: 9.5 ↖ 35: 7.3 ↓ 36: 9.1 ← 37: 10.0 ↑ 38: 9.7 → 39: 10.3 ↖ 40: 9.3 ↓
	Series 87 (2x)		Series 91 (0x)
	264 (4x)		355 (4x)

60 Shots 	41: 7.4 ↑ 42: 7.7 ↑ 43: 9.4 ← 44: 7.0 ← 45: 9.0 ← 46: 8.7 ← 47: 9.7 ↓ 48: 7.9 ↓ 49: 9.0 ↓ 50: 8.1 ←	60 Shots 	51: 8.6 ↓ 52: 9.1 ← 53: 7.9 ↙ 54: 10.4x ↙ 55: 10.3 ↑ 56: 9.2 ↙ 57: 8.7 ↓ 58: 9.6 → 59: 8.6 ↑ 60: 9.9 ↙
	Series 80 (0x)		Series 87 (1x)
	435 (4x)		522 (5x)

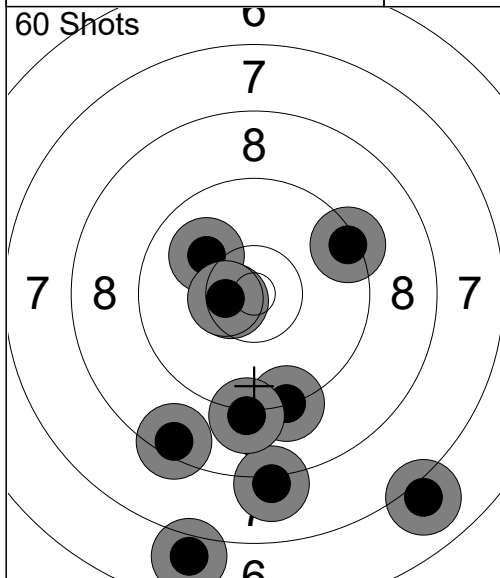

1:	10.0	↖
2:	7.0	↘
3:	10.6x	←
4:	9.2	↘
5:	8.5	↘
6:	10.5x	←
7:	8.1	↘
8:	6.9	↘
9:	9.1	↘
10:	9.4	↗
Series	86 (2x)	
	86 (2x)	

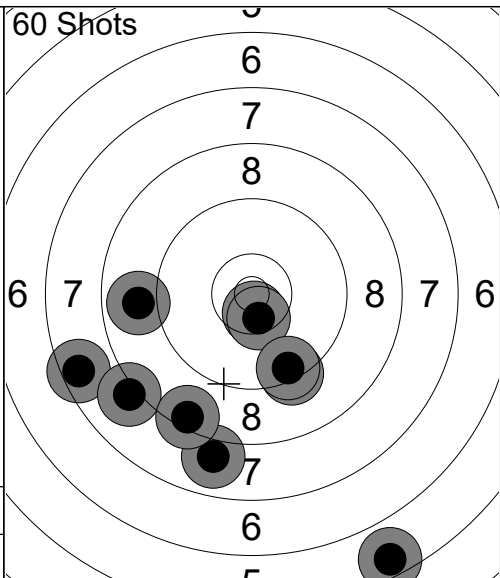

11:	10.6x	↘
12:	7.5	←
13:	5.6	↘
14:	10.5x	↘
15:	8.9	←
16:	9.3	↘
17:	8.1	←
18:	7.9	↘
19:	8.4	↘
20:	9.5	↘
Series	81 (2x)	
	167 (4x)	

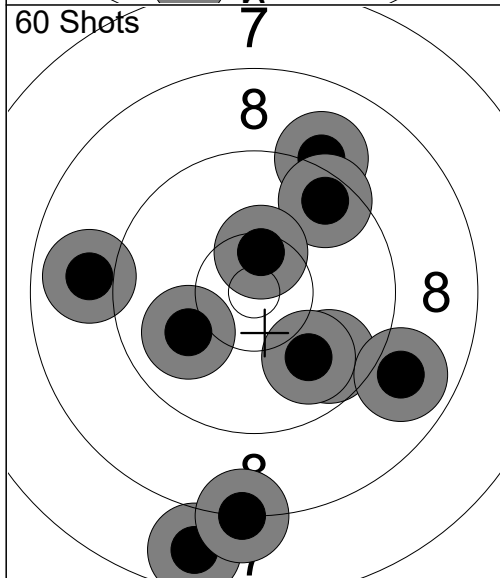

21:	9.8	↘
22:	9.1	↗
23:	8.9	←
24:	9.5	↗
25:	10.0	←
26:	8.9	↗
27:	9.9	↘
28:	10.5x	↗
29:	7.7	↘
30:	8.2	↘
Series	87 (1x)	
	254 (5x)	

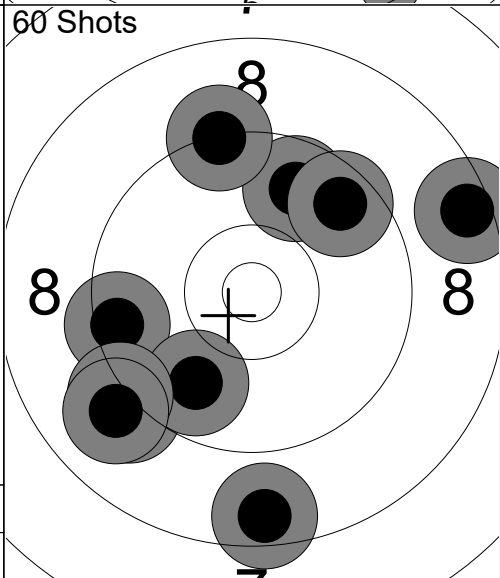

31:	9.7	↗
32:	8.5	↗
33:	9.3	↗
34:	9.6	↗
35:	9.1	↘
36:	9.5	←
37:	8.6	↘
38:	9.8	↘
39:	9.2	↘
40:	9.0	↘
Series	88 (0x)	
	342 (5x)	

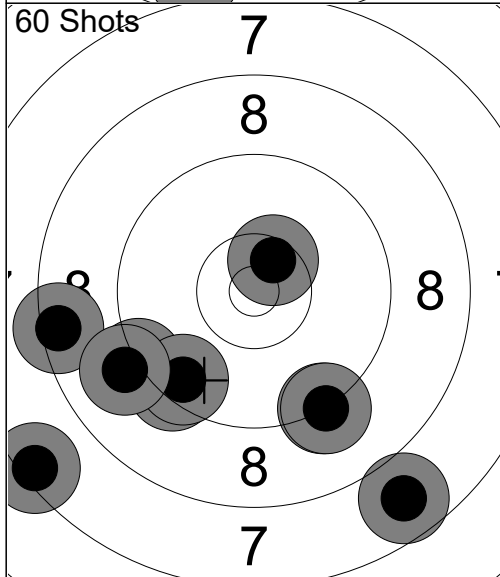

41:	9.2	↘
42:	9.2	←
43:	7.4	←
44:	7.7	↘
45:	9.2	↘
46:	9.4	↘
47:	9.5	↘
48:	8.4	←
49:	9.0	←
50:	10.5x	↗
Series	86 (1x)	
	428 (6x)	

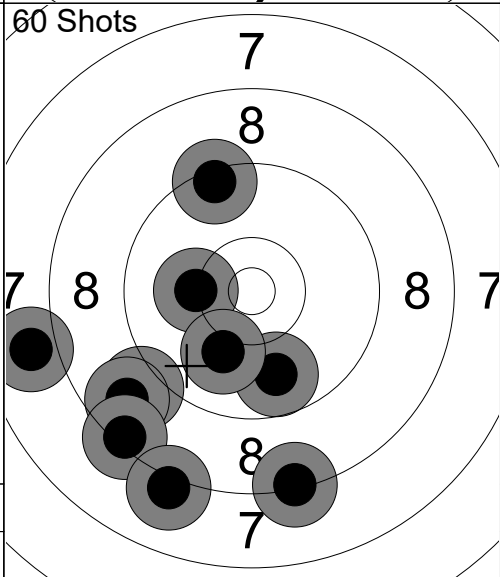

51:	10.2	←
52:	9.8	↘
53:	9.4	↗
54:	9.0	↘
55:	8.7	↘
56:	8.3	↘
57:	7.9	←
58:	10.0	↘
59:	8.4	↘
60:	8.1	↘
Series	86 (0x)	
	514 (6x)	

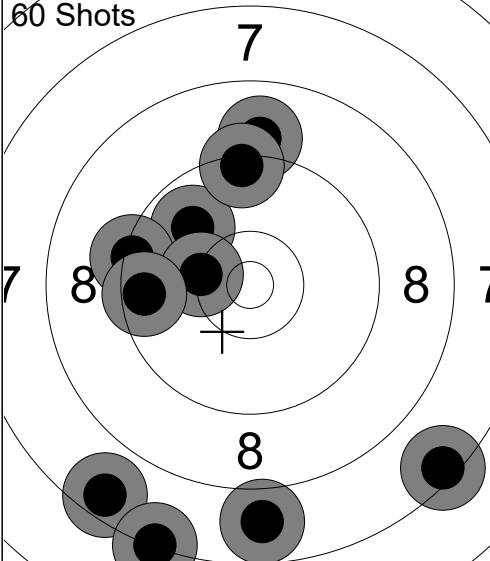
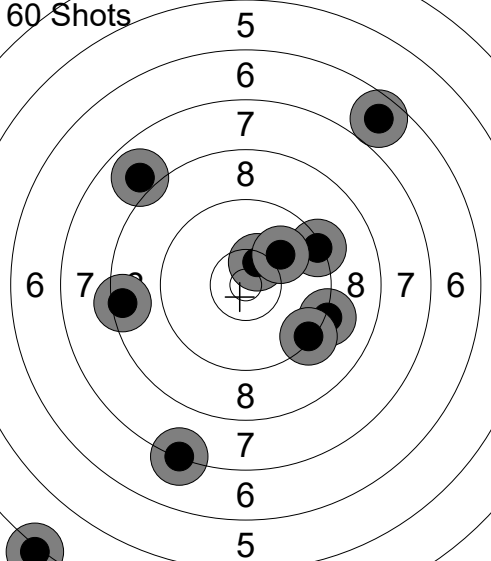
<p>60 Shots</p> 	<p>60 Shots</p> 	<p>11: 9.3 ↗</p> <p>12: 10.4x ↗</p> <p>13: 7.9 ↗</p> <p>14: 9.2 ➡</p> <p>15: 4.1 ↘</p> <p>16: 6.7 ↗</p> <p>17: 9.3 ➡</p> <p>18: 7.3 ↘</p> <p>19: 10.0 ↗</p> <p>20: 8.5 ←</p> <p>Series 79 (1x)</p> <p>162 (1x)</p>
--	--	--

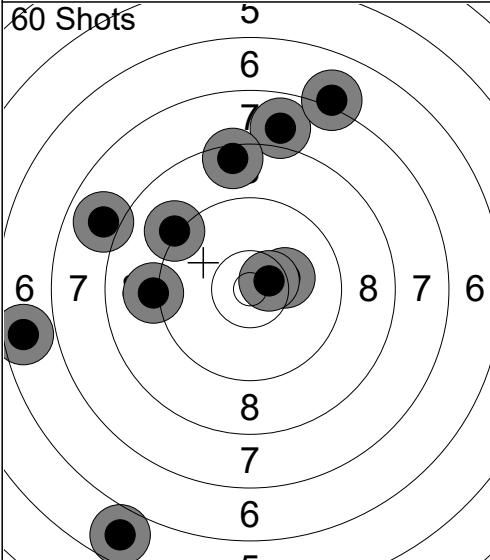
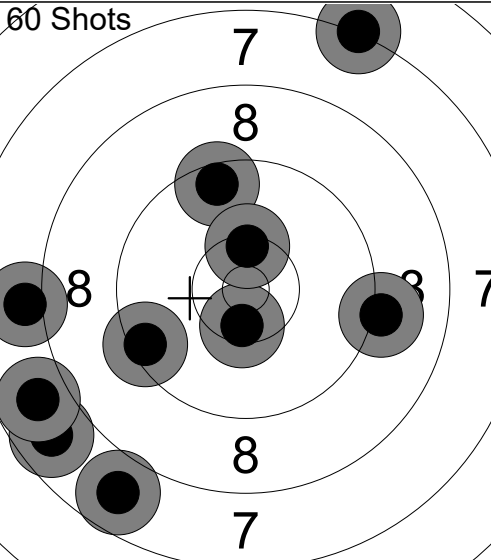
<p>60 Shots</p> 	<p>60 Shots</p> 	<p>21: 10.3 ➡</p> <p>22: 9.1 ←</p> <p>23: 7.9 ↑</p> <p>24: 7.9 ↖</p> <p>25: 8.5 ↑</p> <p>26: 6.6 ←</p> <p>27: 7.1 ↑</p> <p>28: 10.6x ➡</p> <p>29: 5.7 ↘</p> <p>30: 9.2 ↖</p> <p>Series 78 (1x)</p> <p>240 (2x)</p> <p>31: 9.4 ←</p> <p>32: 7.8 ↘</p> <p>33: 9.5 ↑</p> <p>34: 7.7 ↖</p> <p>35: 10.5x ↘</p> <p>36: 8.0 ←</p> <p>37: 7.2 ↑</p> <p>38: 7.8 ←</p> <p>39: 10.4x ↑</p> <p>40: 9.1 ➡</p> <p>Series 83 (2x)</p> <p>323 (4x)</p>
---	---	--

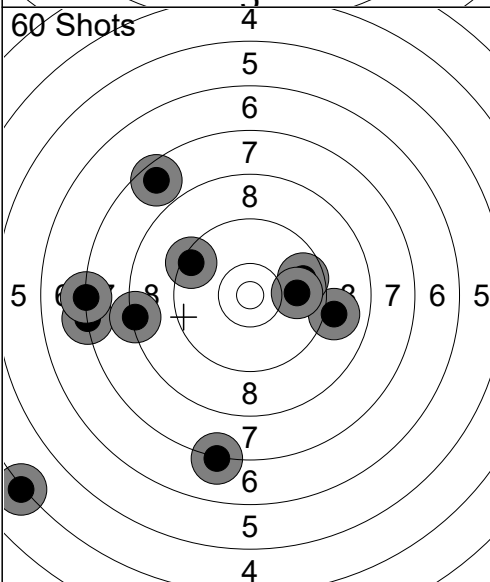
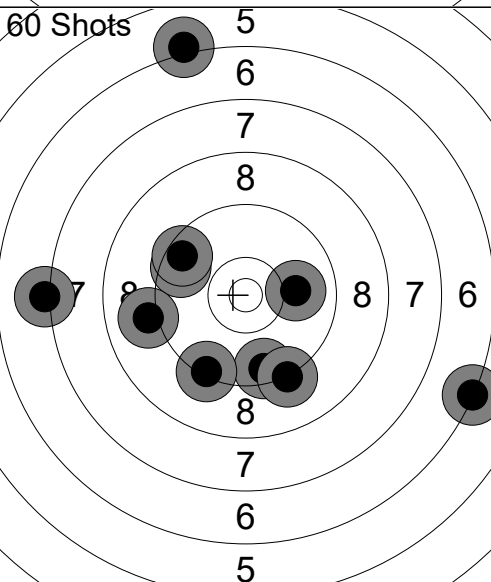
<p>60 Shots</p> 	<p>60 Shots</p> 	<p>41: 9.0 ➡</p> <p>42: 9.4 ↖</p> <p>43: 4.2 ↘</p> <p>44: 9.7 ➡</p> <p>45: 7.2 ←</p> <p>46: 7.2 ↘</p> <p>47: 9.9 ➡</p> <p>48: 7.6 ↗</p> <p>49: 7.3 ←</p> <p>50: 8.3 ←</p> <p>Series 76 (0x)</p> <p>399 (4x)</p> <p>51: 9.6 ↖</p> <p>52: 6.1 ↑</p> <p>53: 9.5 ↘</p> <p>54: 6.2 ➡</p> <p>55: 7.1 ←</p> <p>56: 9.5 ↖</p> <p>57: 9.1 ←</p> <p>58: 10.0 ➡</p> <p>59: 9.2 ↘</p> <p>60: 9.3 ↘</p> <p>Series 83 (0x)</p> <p>482 (4x)</p>
--	--	--

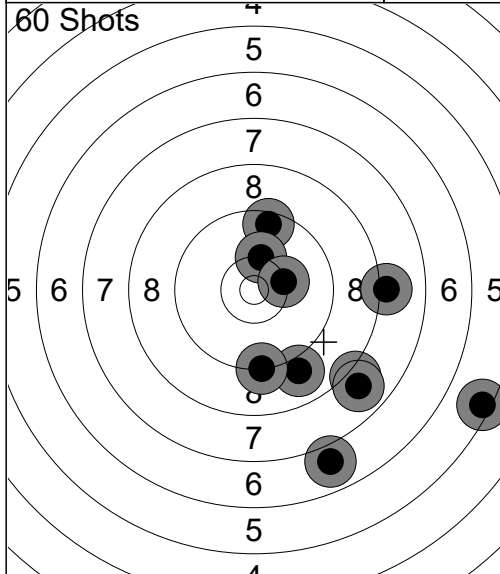

11:	9.2	→
12:	8.1	↘
13:	10.0	↑
14:	10.7x	↗
15:	8.8	↘
16:	10.1	↑
17:	8.2	↘
18:	10.8x	↗
19:	10.5x	↘
20:	10.2	↑
Series	93 (3x)	
	173 (3x)	

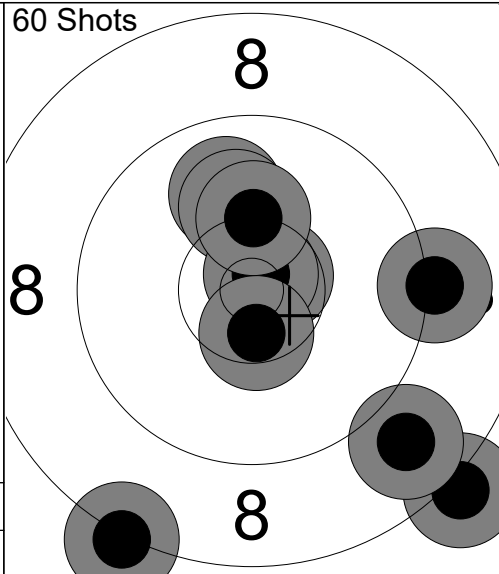

31:	9.3	↗
32:	9.4	↙
33:	7.0	↘
34:	9.6	←
35:	9.5	↘
36:	9.5	↘
37:	9.4	↘
38:	9.5	↘
39:	10.3	→
40:	9.6	↘
Series	89 (0x)	
	351 (4x)	

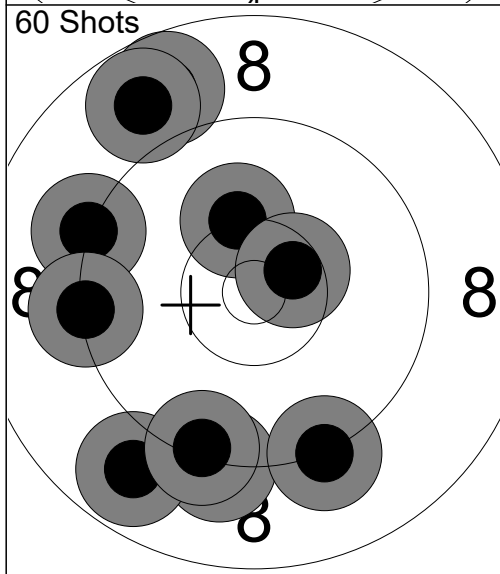

51:	10.6x	↘
52:	9.6	↗
53:	9.3	↘
54:	10.5x	↘
55:	8.5	→
56:	8.4	→
57:	10.3	↘
58:	9.9	↘
59:	9.2	→
60:	7.7	↘
Series	89 (2x)	
	528 (6x)	

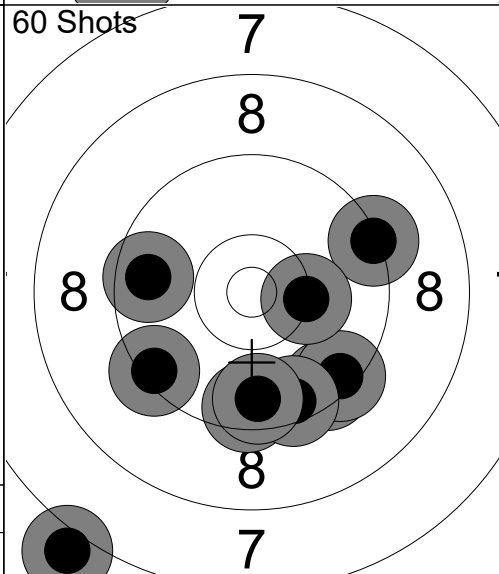

61:	9.7	↑
62:	9.4	↑
63:	8.4	→
64:	10.0	↑
65:	10.2	↘
66:	8.9	→
67:	8.7	↙
68:	9.4	→
69:	8.9	↗
70:	9.3	↙
Series	88 (0x)	
	439 (4x)	

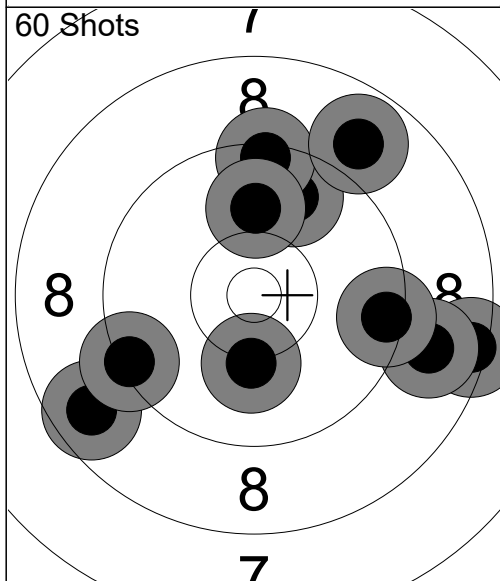

71:	10.6x	↘
72:	9.6	↗
73:	9.3	↘
74:	10.5x	↘
75:	8.5	→
76:	8.4	→
77:	10.3	↘
78:	9.9	↘
79:	9.2	→
80:	7.7	↘
Series	89 (2x)	
	528 (6x)	

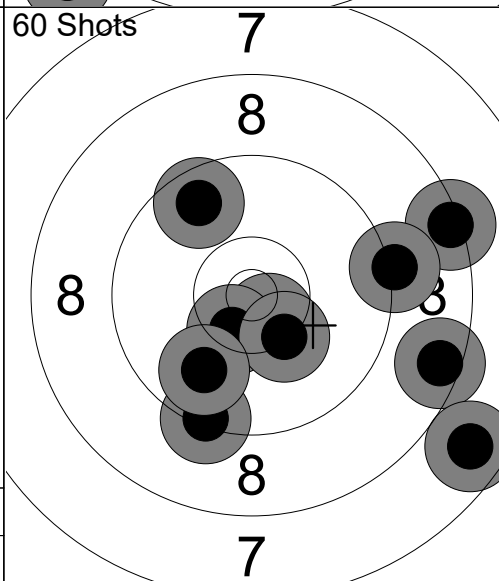

81:	9.7	↑
82:	9.4	↑
83:	8.4	→
84:	10.0	↑
85:	10.2	↘
86:	8.9	→
87:	8.7	↙
88:	9.4	→
89:	8.9	↗
90:	9.3	↙
Series	88 (0x)	
	439 (4x)	

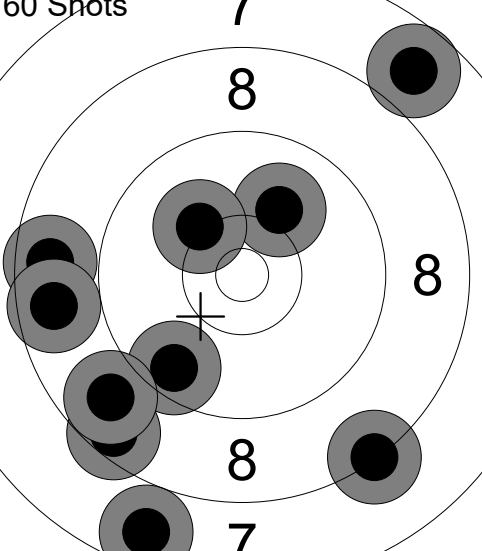
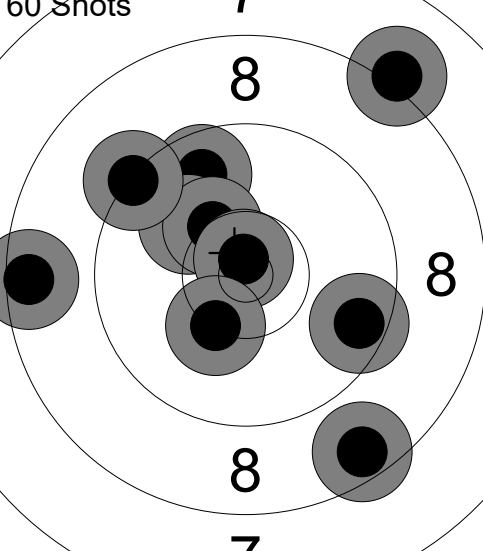
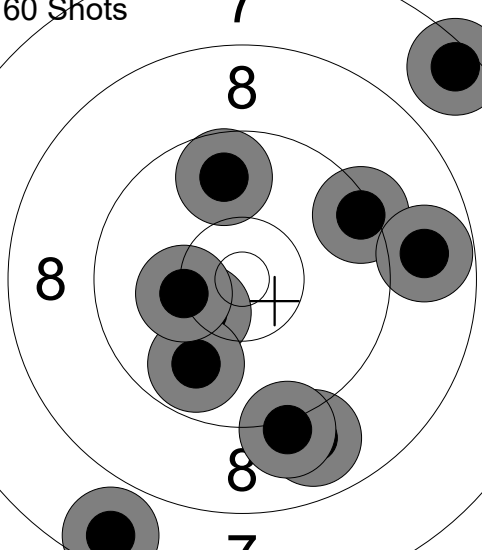
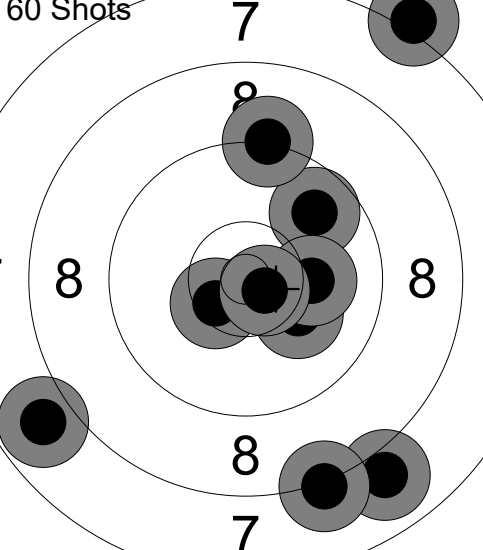
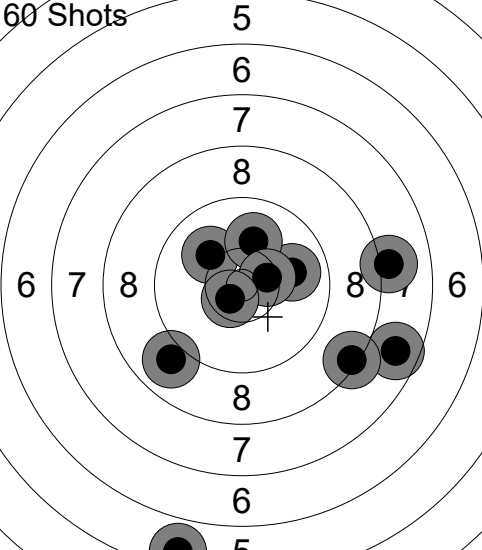
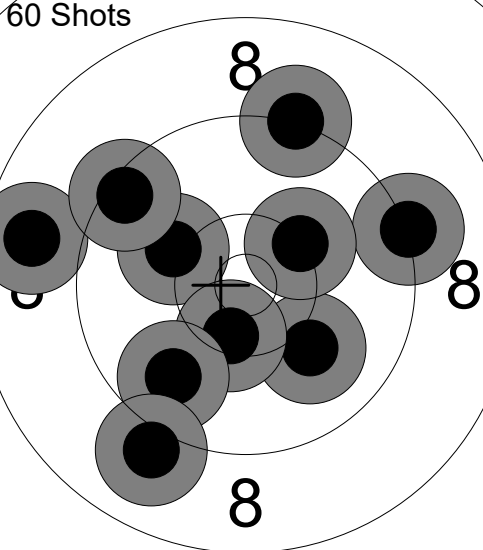
<p>60 Shots</p> 	<p>1: 10.1 ↗ 2: 7.7 ↓ 3: 8.3 ↘ 4: 8.7 ← 5: 7.8 ↗ 6: 9.6 ↓ 7: 8.7 ← 8: 10.2 ↗ 9: 8.5 ↓ 10: 8.8 ↘</p> <p>Series 83 (0x)</p>	<p>60 Shots</p> 	<p>11: 9.7 ↗ 12: 8.5 ← 13: 10.1 ↗ 14: 8.1 ↗ 15: 10.3 ↗ 16: 10.8x ↑ 17: 9.6 → 18: 10.3 ↓ 19: 9.3 ↗ 20: 8.5 ↘</p> <p>Series 91 (1x)</p>
<p>60 Shots</p> 	<p>21: 9.4 → 22: 7.6 ↓ 23: 10.4 ↘ 24: 9.7 ↑ 25: 8.8 → 26: 9.8 ↓ 27: 10.3 ← 28: 8.9 ↓ 29: 7.5 ↗ 30: 9.1 ↓</p> <p>Series 86 (0x)</p>	<p>60 Shots</p> 	<p>31: 9.8 ↗ 32: 10.2 ↘ 33: 7.9 ↓ 34: 10.5x ↘ 35: 8.2 ↓ 36: 10.1 → 37: 9.2 ↑ 38: 7.1 ↗ 39: 7.8 ← 40: 10.7x →</p> <p>Series 87 (2x)</p>
<p>60 Shots</p> 	<p>41: 10.1 ↖ 42: 9.9 → 43: 5.6 ↓ 44: 10.1 ↑ 45: 10.4x → 46: 10.6x ↘ 47: 7.7 → 48: 8.4 ↘ 49: 8.0 → 50: 8.9 ↘</p> <p>Series 85 (2x)</p>	<p>60 Shots</p> 	<p>51: 8.7 ← 52: 9.2 → 53: 9.2 ↑ 54: 10.1 ← 55: 10.0 ↘ 56: 10.3 ↗ 57: 10.4x ↓ 58: 9.8 ↓ 59: 9.4 ↖ 60: 9.0 ↓</p> <p>Series 93 (1x)</p>
432 (5x)		525 (6x)	

Relay 3	Lane 67	ARKIN Elie
-------------------	-------------------	-------------------

1-80	NoVA Frame Hitters	Pistol
------	--------------------	--------

31.01.2025	2025 AirNats by X Count	Civilian Marksmanship Program
------------	-------------------------	-------------------------------

Comment	Signature
---------	-----------

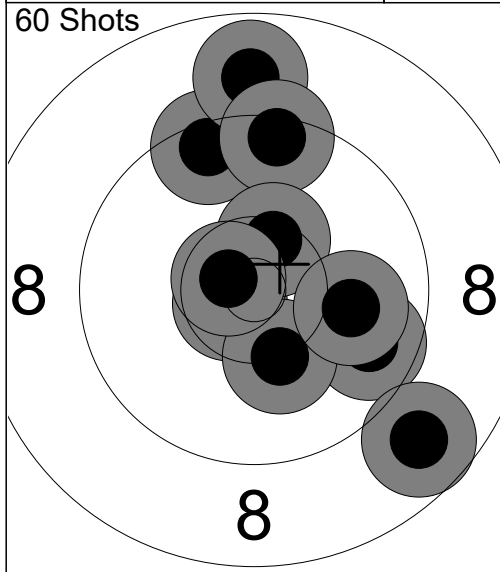

1:	9.5	↑
2:	8.9	↑
3:	9.4	↑
4:	10.7x	↙
5:	9.7	➤
6:	8.8	↘
7:	10.4x	↑
8:	10.3	↘
9:	10.0	➤
10:	10.7x	↙
Series	93 (3x)	
	93 (3x)	

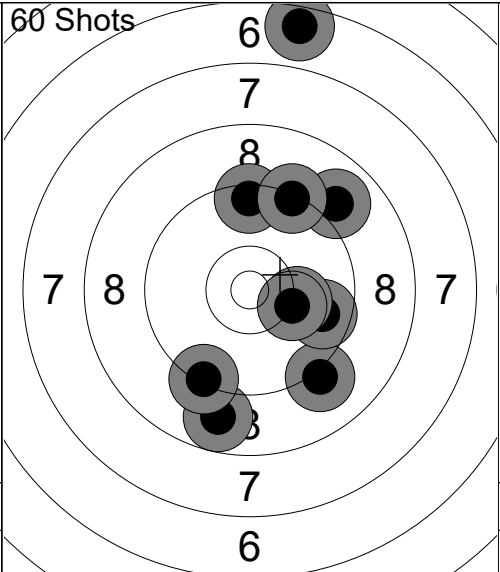

11:	8.8	↘
12:	9.4	↑
13:	8.9	↗
14:	9.3	↘
15:	9.1	↘
16:	9.7	➤
17:	10.1	➤
18:	10.2	➤
19:	6.5	↑
20:	9.3	↑
Series	87 (0x)	
	180 (3x)	

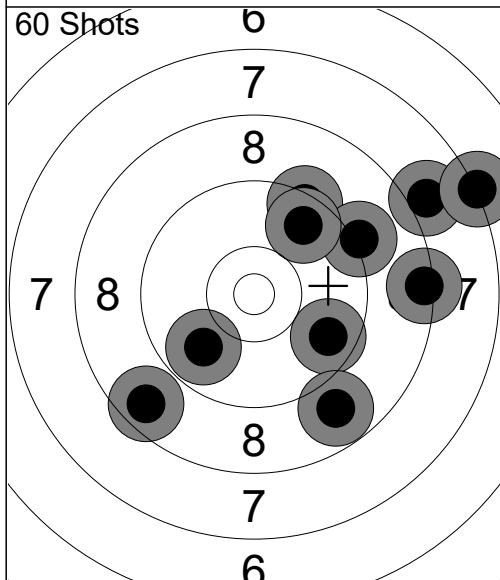

21:	9.4	↑
22:	8.6	↙
23:	9.1	↗
24:	8.4	➤
25:	8.0	↗
26:	9.7	↑
27:	9.7	➤
28:	9.8	↙
29:	7.2	↗
30:	8.8	↘
Series	84 (0x)	
	264 (3x)	

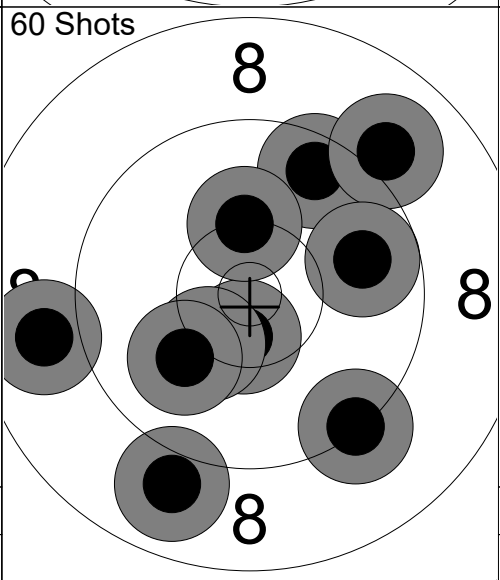

31:	8.9	↙
32:	8.9	↘
33:	10.5x	↘
34:	9.6	↑
35:	9.0	↗
36:	9.8	➤
37:	10.3	↙
38:	9.3	↘
39:	10.3	↑
40:	10.1	↙
Series	92 (1x)	
	356 (4x)	

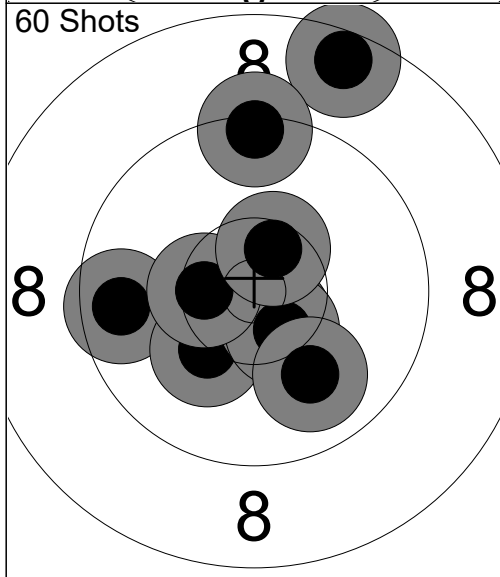

41:	8.5	↑
42:	9.6	↙
43:	10.6x	↘
44:	10.2	↙
45:	10.6x	↘
46:	10.5x	↘
47:	9.4	↑
48:	10.5x	↙
49:	10.0	↘
50:	10.5x	↑
Series	96 (5x)	
	452 (9x)	

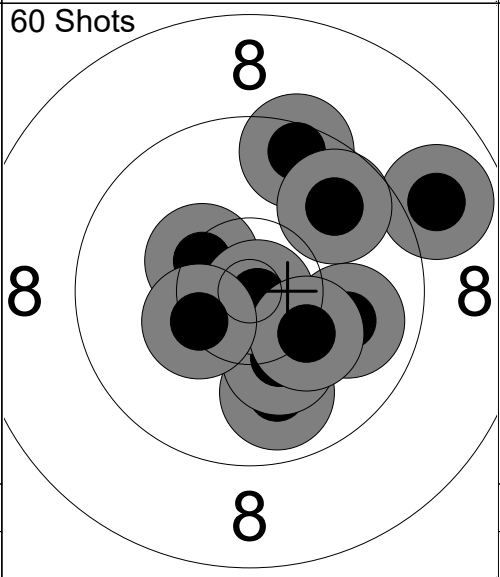

51:	9.5	↑
52:	8.9	↗
53:	9.9	↘
54:	9.8	↗
55:	10.4x	↙
56:	10.2	↘
57:	10.9x	↘
58:	10.0	➤
59:	10.3	↘
60:	10.4x	↙
Series	95 (3x)	
	547 (12x)	

<p>60 Shots</p>	<p>60 Shots</p>	<p>11: 9.7 ↘ 12: 10.2 ↘ 13: 9.6 ↖ 14: 9.4 ↙ 15: 9.7 ↖ 16: 8.9 ← 17: 10.2 ↖ 18: 10.4 → 19: 9.1 ← 20: 9.8 ↗</p> <p>Series 92 (0x) 183 (2x)</p>
-----------------	-----------------	--

<p>60 Shots</p>	<p>60 Shots</p>	<p>21: 10.2 ↖ 22: 8.8 → 23: 10.2 ↖ 24: 9.0 ↗ 25: 9.8 ↗ 26: 9.7 ↗ 27: 10.5x ↑ 28: 10.1 ↖ 29: 9.6 ← 30: 10.3 ←</p> <p>Series 94 (1x) 277 (3x)</p>
-----------------	-----------------	---

<p>60 Shots</p>	<p>60 Shots</p>	<p>31: 9.5 ↗ 32: 10.1 ↑ 33: 9.7 ↑ 34: 9.0 ← 35: 9.6 ↓ 36: 10.1 ↗ 37: 9.7 ↖ 38: 9.9 ↗ 39: 9.1 ↓ 40: 8.9 →</p> <p>Series 91 (0x) 368 (3x)</p>
-----------------	-----------------	---

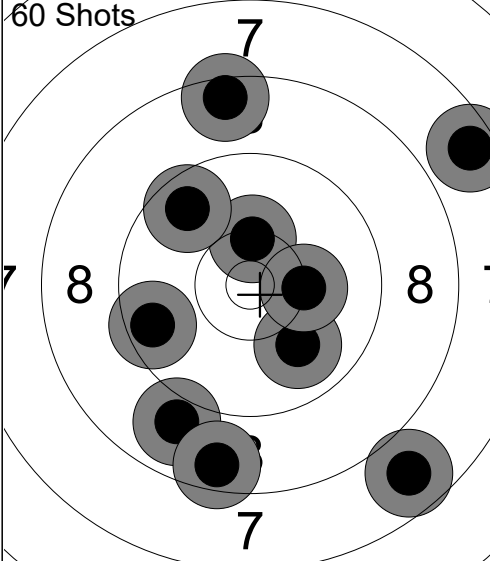
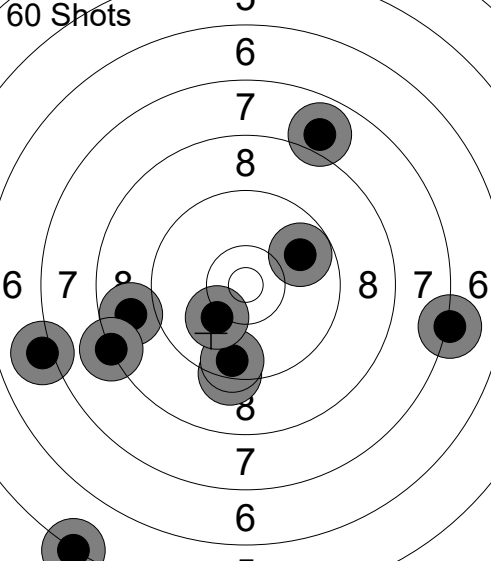
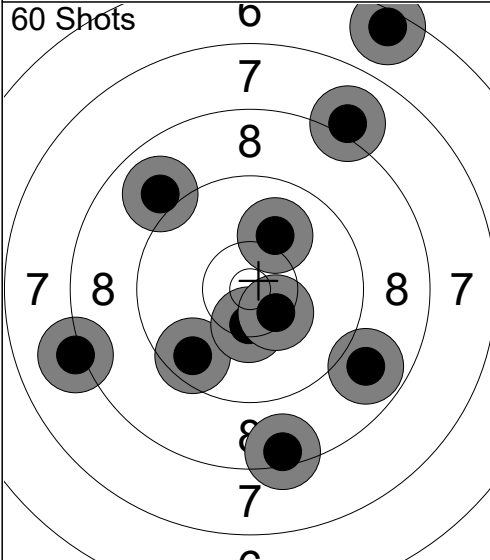
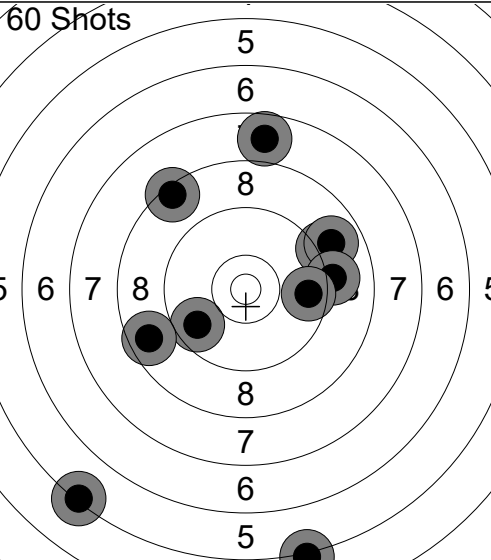
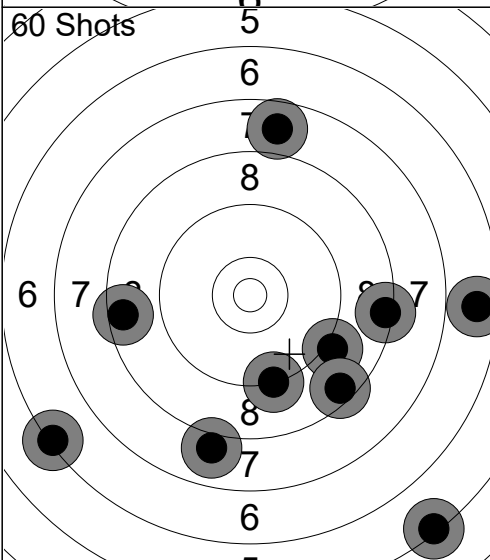
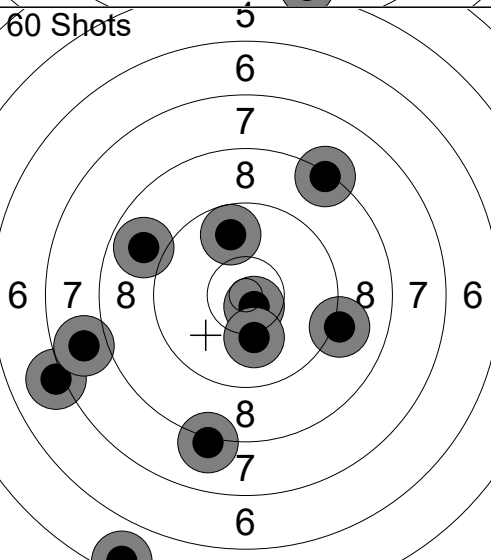
<p>60 Shots</p> 	<p>1: 10.3 ↑ 2: 8.9 ↓ 3: 7.7 ↓ 4: 7.6 → 5: 8.6 ↓ 6: 8.5 ↑ 7: 10.0 ↓ 8: 9.7 ↑ 9: 10.2 → 10: 9.6 ←</p> <p>Series 86 (0x) 86 (0x)</p>	<p>60 Shots</p>  <p>11: 8.8 ← 12: 8.2 ← 13: 7.9 ↑ 14: 9.3 ↓ 15: 7.2 → 16: 9.6 ↓ 17: 10.2 ↓ 18: 7.1 ← 19: 9.8 → 20: 5.2 ↓</p> <p>Series 79 (0x) 165 (0x)</p>
<p>60 Shots</p> 	<p>21: 8.0 ↑ 22: 8.4 ↓ 23: 9.0 ↑ 24: 9.6 ↓ 25: 8.8 → 26: 10.4x ↓ 27: 6.5 ↑ 28: 8.1 ← 29: 10.4x ↓ 30: 10.1 ↑</p> <p>Series 86 (2x) 251 (2x)</p>	<p>60 Shots</p>  <p>31: 9.7 ↓ 32: 9.1 → 33: 8.7 ← 34: 8.4 ↑ 35: 5.2 ↓ 36: 8.9 → 37: 9.1 → 38: 9.6 → 39: 5.3 ↓ 40: 7.7 ↑</p> <p>Series 77 (0x) 328 (2x)</p>
<p>60 Shots</p> 	<p>41: 6.3 ← 42: 5.3 ↓ 43: 9.1 → 44: 8.4 → 45: 6.6 → 46: 9.2 ↓ 47: 7.7 ↑ 48: 8.0 ↓ 49: 8.5 ← 50: 8.5 ↓</p> <p>Series 74 (0x) 402 (2x)</p>	<p>60 Shots</p>  <p>51: 10.7x ↓ 52: 9.8 ↑ 53: 9.1 → 54: 10.1 ↓ 55: 8.1 ↓ 56: 7.1 ← 57: 5.5 ↓ 58: 8.3 ↑ 59: 8.9 ← 60: 7.8 ←</p> <p>Series 81 (1x) 483 (3x)</p>

Relay 3	Lane 70	WANG Nina
-------------------	-------------------	------------------

1-80	NoVA Target Masters	Pistol
------	---------------------	--------

31.01.2025	2025 AirNats by X Count	Civilian Marksmanship Program
------------	-------------------------	-------------------------------

Comment	Signature	
---------	-----------	--

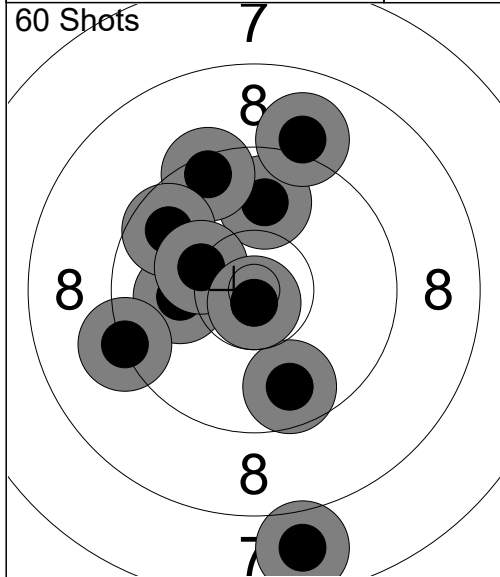

1:	9.9	↑
2:	7.8	↓
3:	10.1	←
4:	9.7	↓
5:	9.1	↑
6:	9.5	↑
7:	9.7	↗
8:	10.3	↖
9:	10.8x	↓
10:	9.3	←
Series	91 (1x)	
	91 (1x)	

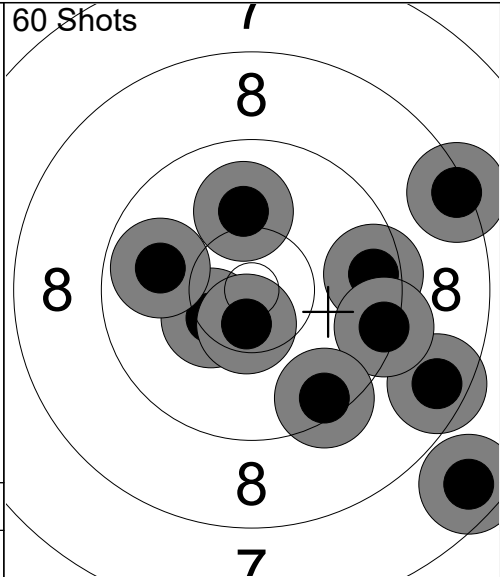

11:	10.0	↑
12:	8.4	↗
13:	9.6	→
14:	7.6	↘
15:	8.6	↘
16:	9.4	→
17:	9.5	↘
18:	10.4x	↖
19:	9.9	←
20:	10.6x	↓
Series	89 (2x)	
	180 (3x)	

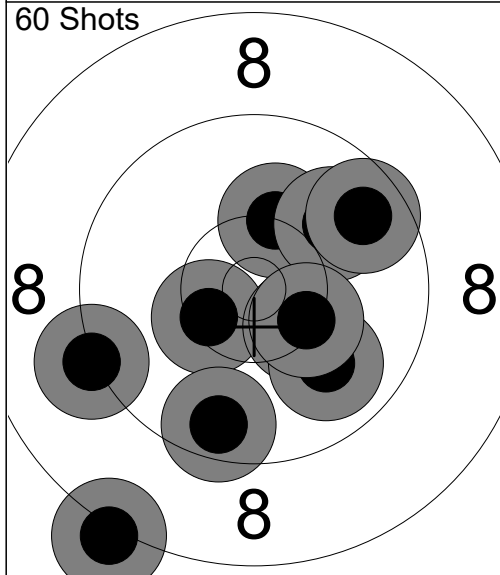

21:	10.2	↑
22:	9.2	←
23:	10.4x	↖
24:	10.4x	↘
25:	10.0	↗
26:	9.7	↗
27:	9.9	↘
28:	10.4	→
29:	8.1	↓
30:	9.6	↓
Series	94 (2x)	
	274 (5x)	

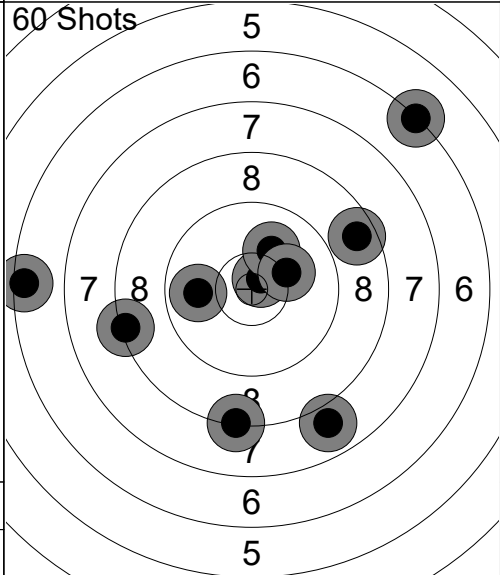

31:	10.7x	↗
32:	6.4	←
33:	7.9	↘
34:	10.1	↑
35:	9.9	←
36:	8.6	↗
37:	8.3	↓
38:	6.3	↗
39:	8.3	←
40:	10.2	↗
Series	82 (1x)	
	356 (6x)	

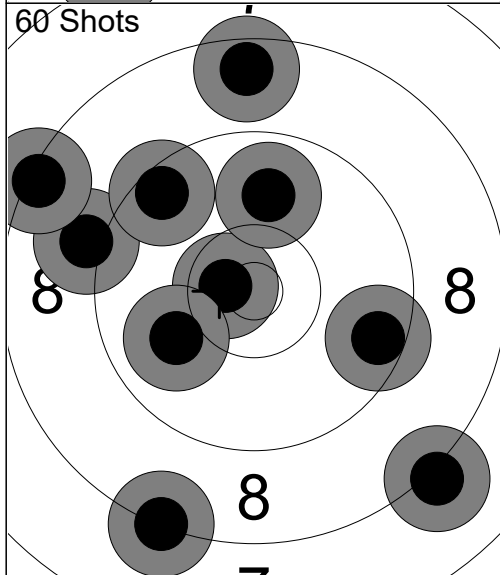

41:	8.3	↓
42:	9.5	→
43:	10.6x	←
44:	10.0	←
45:	9.1	←
46:	8.1	↘
47:	8.3	↗
48:	8.6	↑
49:	9.5	↗
50:	9.9	↑
Series	88 (1x)	
	444 (7x)	

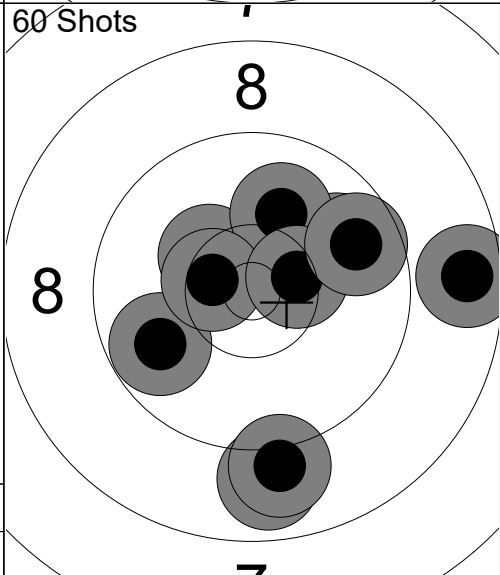

51:	9.9	↗
52:	10.4	↖
53:	8.9	↓
54:	10.1	↑
55:	9.8	←
56:	8.6	→
57:	10.5x	←
58:	10.4x	→
59:	9.7	↗
60:	9.0	↓
Series	92 (2x)	
	536 (9x)	

<p>60 Shots</p>	<p>1: 9.8 ↓ 2: 9.8 ↙ 3: 9.7 → 4: 9.6 ↘ 5: 9.8 ↓ 6: 9.6 ↘ 7: 8.4 ↓ 8: 6.9 ↓ 9: 10.1 ↗ 10: 7.9 ↓</p> <p>Series 85 (0x) 85 (0x)</p>	<p>60 Shots</p>	<p>11: 9.4 → 12: 10.2 ↗ 13: 9.0 ↓ 14: 10.5x → 15: 8.4 ↓ 16: 10.4x → 17: 10.0 → 18: 9.7 ↑ 19: 9.3 ↑ 20: 9.8 ↘</p> <p>Series 93 (2x) 178 (2x)</p>
<p>60 Shots</p>	<p>21: 9.3 ↘ 22: 9.8 ← 23: 9.1 ↓ 24: 9.3 ↓ 25: 9.7 ↗ 26: 8.7 ↓ 27: 8.3 ← 28: 9.6 ↘ 29: 9.7 ↘ 30: 9.4 ←</p> <p>Series 88 (0x) 266 (2x)</p>	<p>60 Shots</p>	<p>31: 9.7 → 32: 9.0 ↙ 33: 9.6 → 34: 10.2 ↙ 35: 10.4x → 36: 7.6 ← 37: 9.8 ← 38: 10.2 ↓ 39: 10.3 ← 40: 9.6 ↓</p> <p>Series 92 (1x) 358 (3x)</p>
<p>60 Shots</p>	<p>41: 9.5 ↘ 42: 10.6x ↑ 43: 10.0 ↗ 44: 10.1 → 45: 8.1 ↗ 46: 8.5 ← 47: 9.3 ↑ 48: 10.4x → 49: 9.1 ← 50: 7.7 ↓</p> <p>Series 90 (2x) 448 (5x)</p>	<p>60 Shots</p>	<p>51: 9.9 → 52: 7.9 ↙ 53: 10.3 ↑ 54: 8.4 ↙ 55: 9.6 ↓ 56: 8.6 ↙ 57: 10.2 ↓ 58: 8.2 ↓ 59: 8.7 ↓ 60: 8.7 ↓</p> <p>Series 85 (0x) 533 (5x)</p>

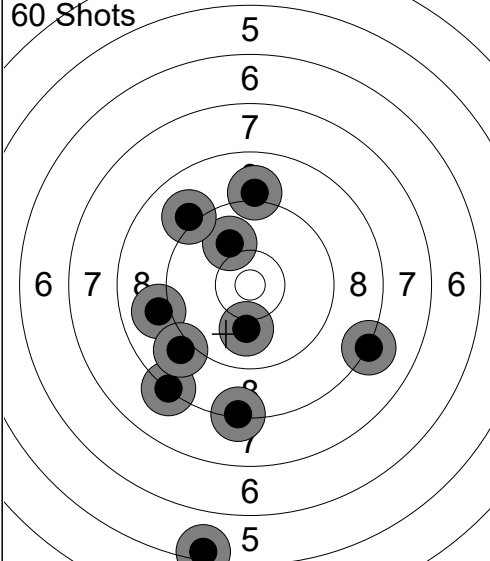
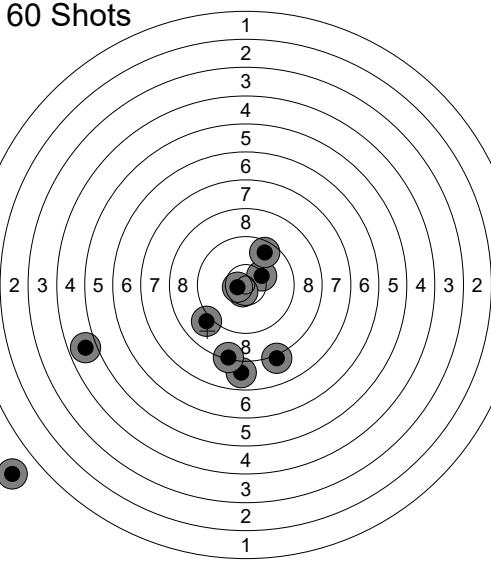
<p>60 Shots</p> 	<p>60 Shots</p> 	<p>11: 10.3 →</p> <p>12: 7.8 ↓</p> <p>13: 8.1 ↓</p> <p>14: 9.6 ↗</p> <p>15: 0.0 ↙</p> <p>16: 8.3 ↓</p> <p>17: 4.8 ←</p> <p>18: 9.0 ↙</p> <p>19: 10.7x ↓</p> <p>20: 10.7x ←</p> <p>Series 75 (2x)</p> <p>160 (2x)</p>
--	--	--

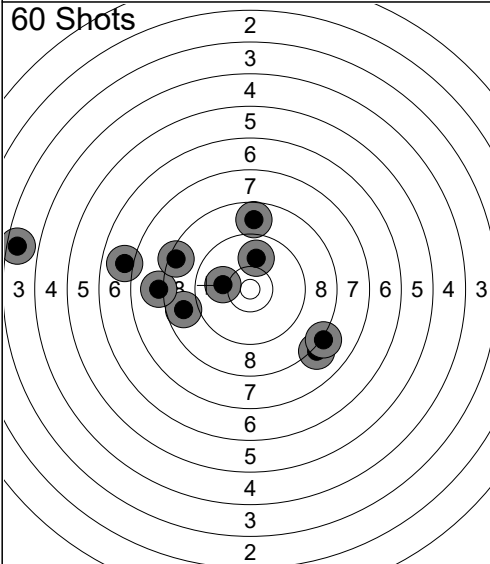
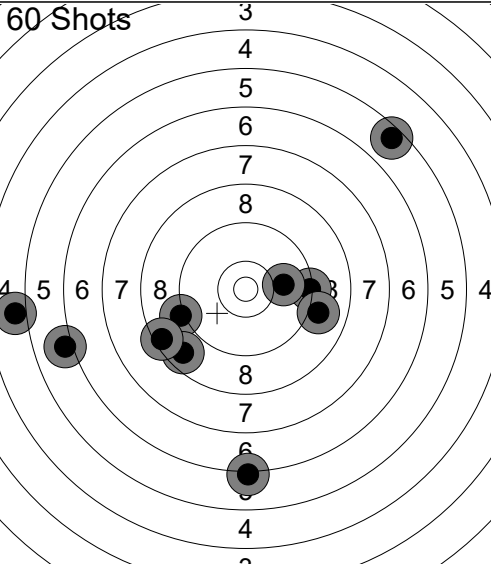
<p>60 Shots</p> 	<p>60 Shots</p> 	<p>21: 8.8 ←</p> <p>22: 3.6 ←</p> <p>23: 8.1 ↘</p> <p>24: 8.1 ←</p> <p>25: 8.5 ↗</p> <p>26: 10.1 ←</p> <p>27: 7.0 ←</p> <p>28: 8.8 ↑</p> <p>29: 10.0 ↑</p> <p>30: 8.2 ↘</p> <p>Series 78 (0x)</p> <p>238 (2x)</p>
---	---	---

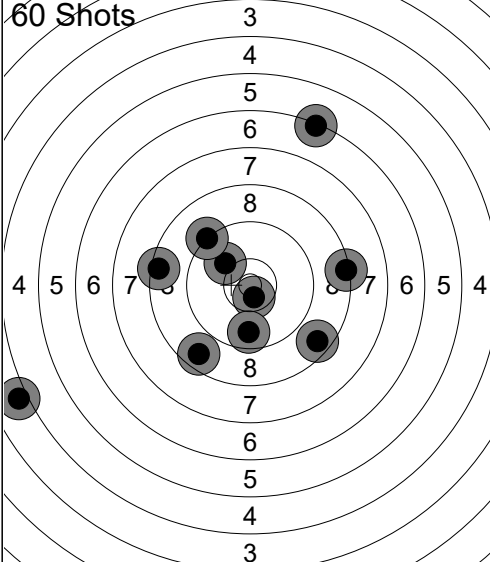
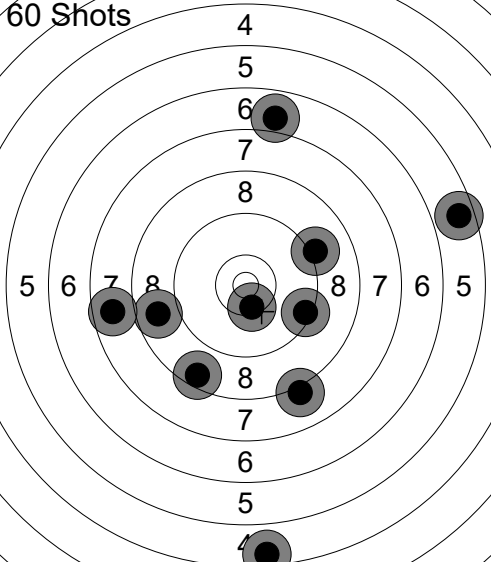
<p>60 Shots</p> 	<p>60 Shots</p> 	<p>31: 5.5 ↗</p> <p>32: 6.2 ↓</p> <p>33: 9.3 →</p> <p>34: 9.1 ←</p> <p>35: 4.9 ←</p> <p>36: 9.0 →</p> <p>37: 6.0 ←</p> <p>38: 8.6 ↙</p> <p>39: 10.0 →</p> <p>40: 8.4 ←</p> <p>Series 74 (0x)</p> <p>312 (2x)</p>
--	--	--

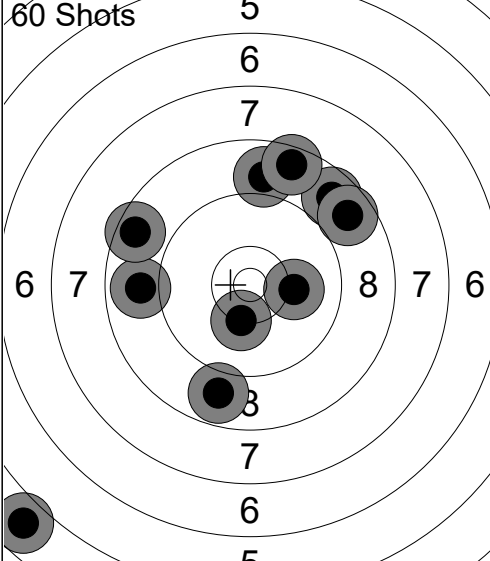
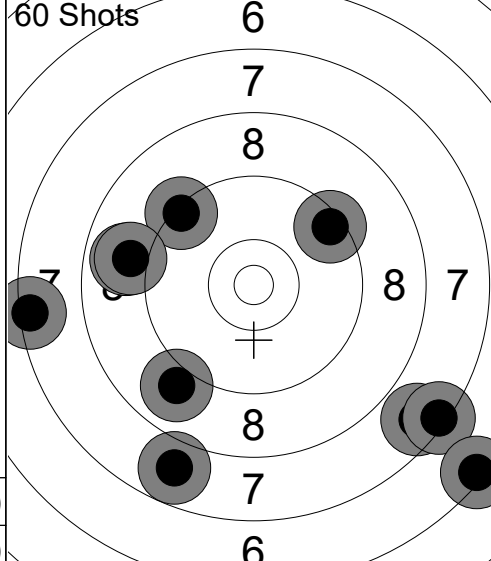
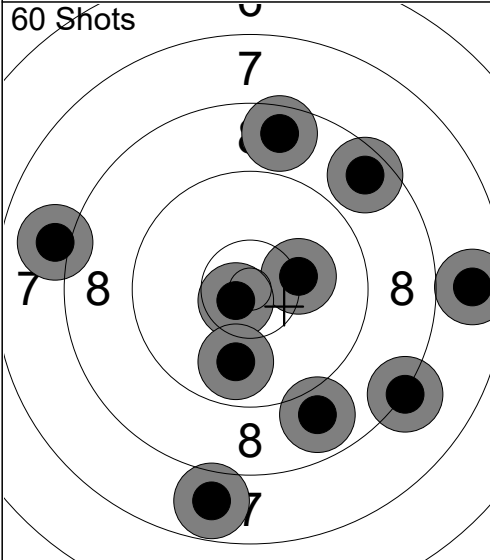
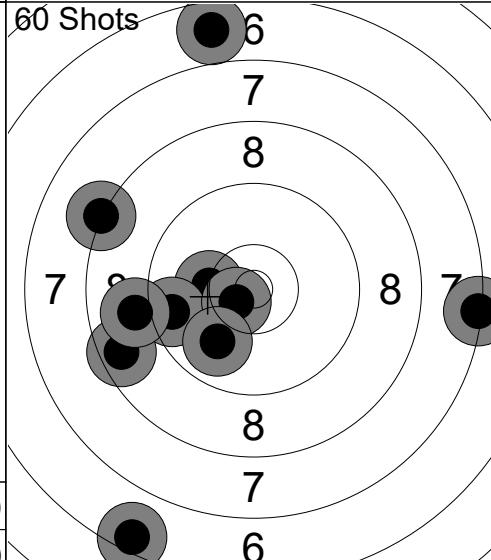
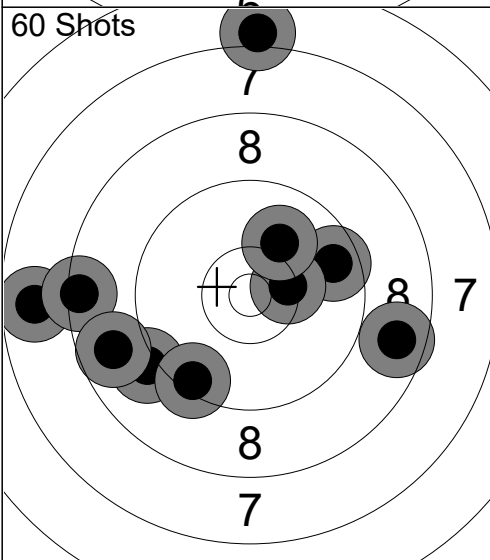
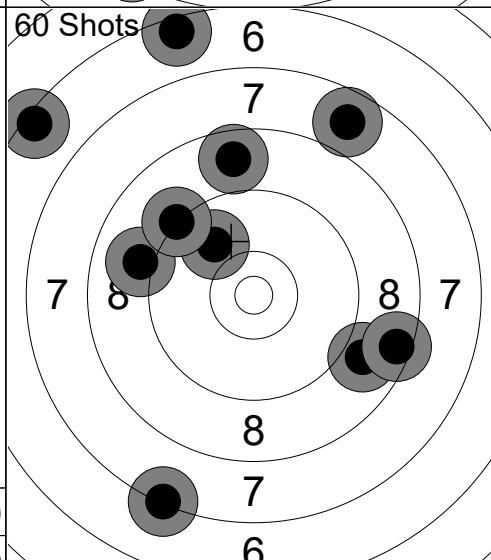
<p>60 Shots</p>  <p style="text-align: center;">5 6 7 6 7 8 7 6 8 7 6</p>	<p>1: 10.3 ↓ 2: 10.1 → 3: 4.8 ↙ 4: 8.9 ↑ 5: 8.9 ← 6: 8.8 ↓ 7: 8.7 ↗ 8: 8.6 ↑ 9: 8.7 ↗ 10: 8.6 ←</p> <p>Series 80 (0x) 80 (0x)</p>	<p>60 Shots</p>  <p style="text-align: center;">6 7 8 7 8 7 8 8 7</p>	<p>11: 9.3 ↗ 12: 7.8 ↓ 13: 8.9 ← 14: 9.4 ↗ 15: 7.4 ← 16: 7.6 ↘ 17: 9.0 ↓ 18: 7.4 ↘ 19: 9.0 ← 20: 6.4 ↘</p> <p>Series 78 (0x) 158 (0x)</p>
<p>60 Shots</p>  <p style="text-align: center;">5 7 7 8 8 8 8 7</p>	<p>21: 8.6 ↑ 22: 8.9 ↓ 23: 10.2 → 24: 7.8 ↓ 25: 8.2 ↘ 26: 8.0 ← 27: 10.7x ↙ 28: 9.9 ↓ 29: 8.6 ↗ 30: 7.7 →</p> <p>Series 83 (1x) 241 (1x)</p>	<p>60 Shots</p>  <p style="text-align: center;">6 7 8 7 8 8 7 8 7 6</p>	<p>31: 6.5 ↓ 32: 8.6 ← 33: 10.2 ← 34: 9.6 ← 35: 10.6x ↙ 36: 8.2 ← 37: 6.7 ↑ 38: 9.9 ↓ 39: 7.3 → 40: 9.0 ←</p> <p>Series 82 (1x) 323 (2x)</p>
<p>60 Shots</p>  <p style="text-align: center;">6 7 8 8 7 8 7 6</p>	<p>41: 9.6 → 42: 10.4x → 43: 9.1 ← 44: 7.7 ← 45: 8.7 → 46: 10.1 ↗ 47: 8.4 ← 48: 8.7 ← 49: 9.4 ↓ 50: 7.0 ↑</p> <p>Series 85 (1x) 408 (3x)</p>	<p>60 Shots</p>  <p style="text-align: center;">6 7 8 7 8 7 8 7 6</p>	<p>51: 6.4 ↖ 52: 7.7 ↗ 53: 8.9 ↘ 54: 9.9 ↗ 55: 9.0 ← 56: 7.3 ↓ 57: 9.2 ↗ 58: 6.5 ↑ 59: 8.5 → 60: 8.7 ↑</p> <p>Series 77 (0x) 485 (3x)</p>

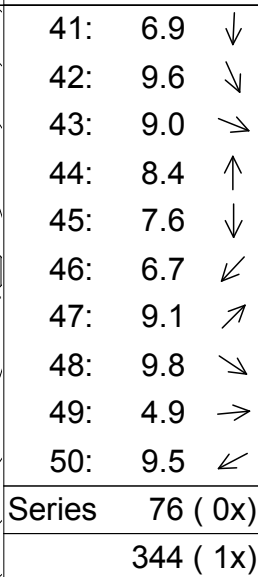
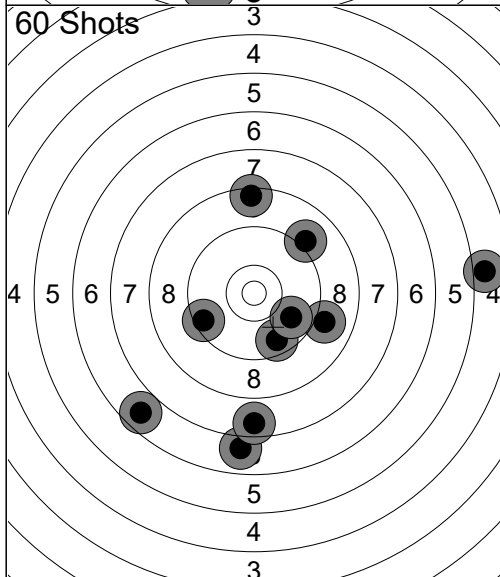
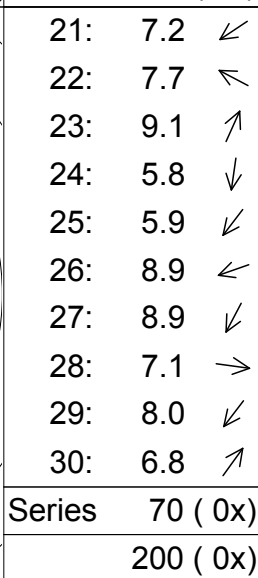
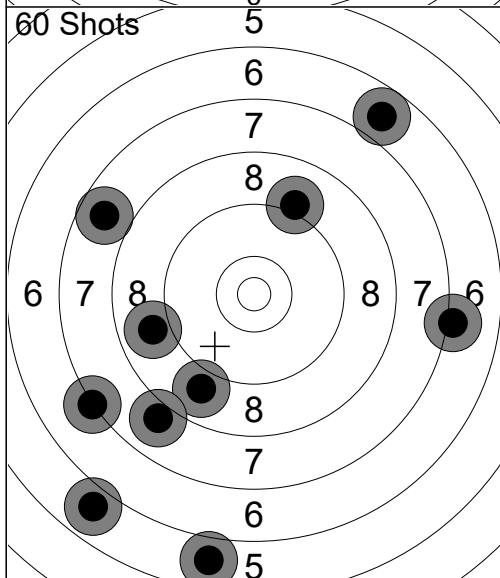
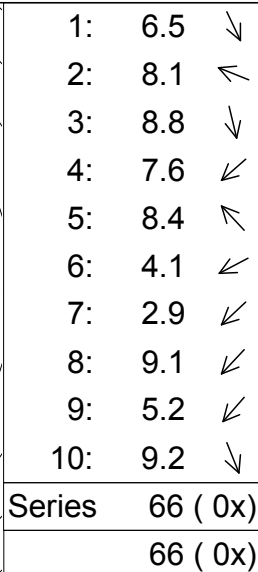
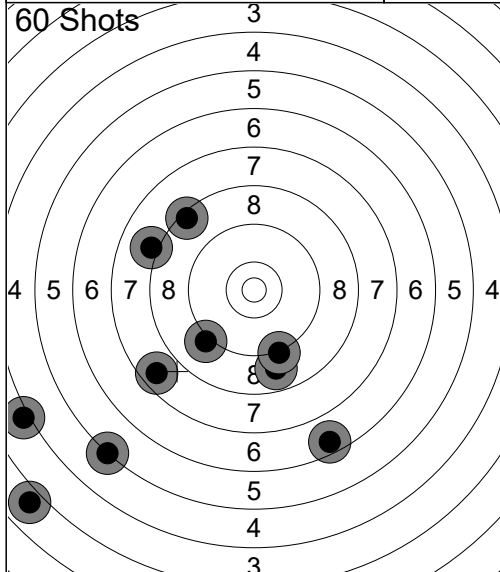

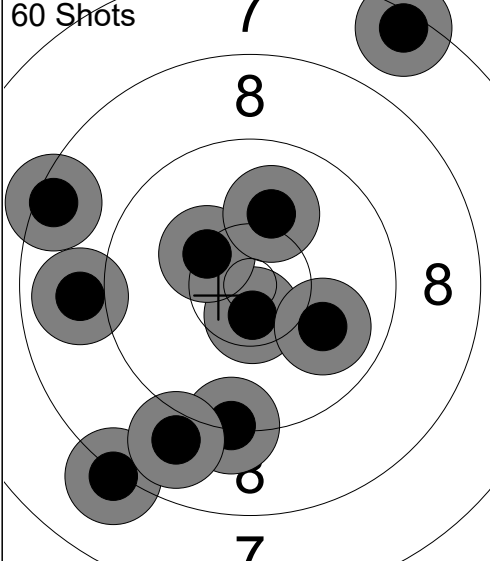
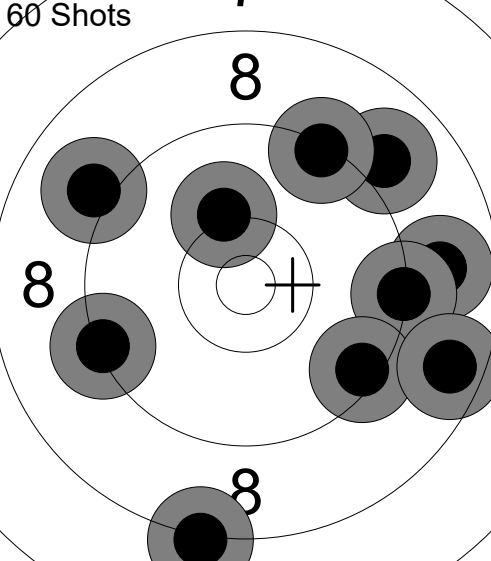
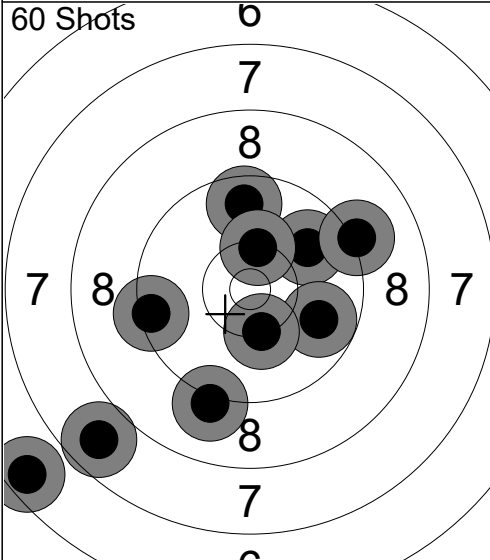
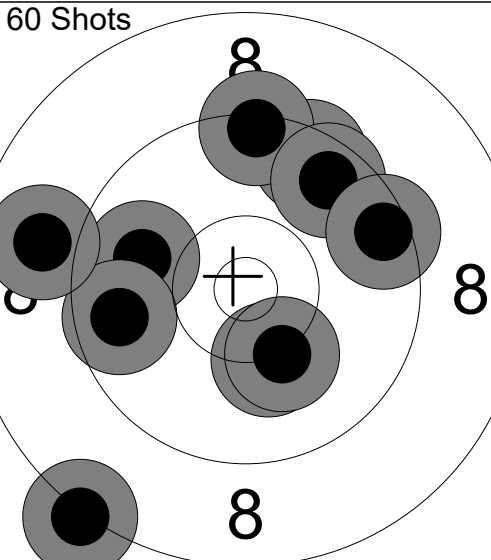
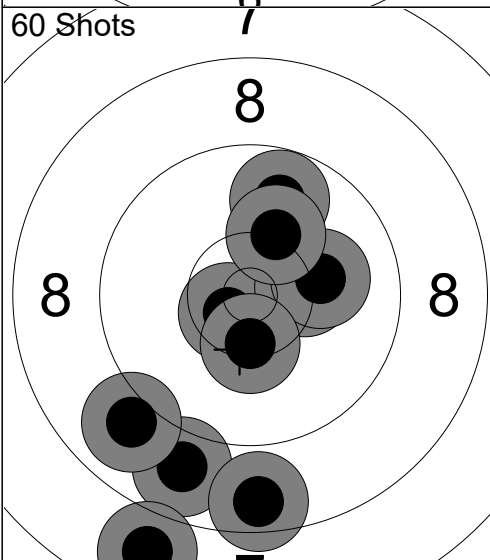
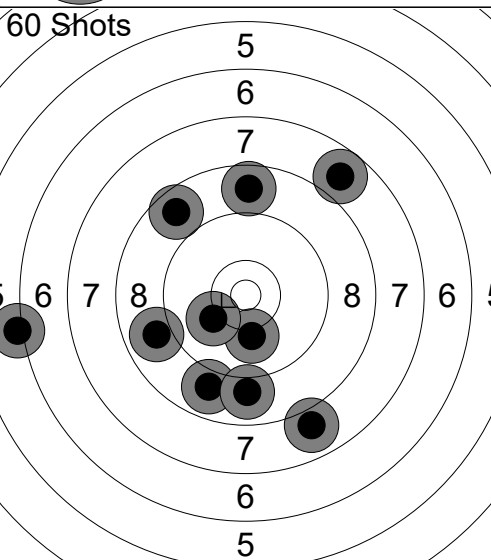
<p>60 Shots</p> 	<p>60 Shots</p> 	<p>11: 8.2 ↓</p> <p>12: 9.0 ↖</p> <p>13: 10.2 ↑</p> <p>14: 8.9 →</p> <p>15: 9.3 →</p> <p>16: 9.0 ↗</p> <p>17: 9.3 ↑</p> <p>18: 9.4 ↘</p> <p>19: 8.6 →</p> <p>20: 9.3 ←</p> <p>Series 88 (0x)</p> <p>176 (1x)</p>
<p>60 Shots</p> 	<p>60 Shots</p> 	<p>21: 7.7 ↘</p> <p>22: 9.1 ↓</p> <p>23: 6.6 ↘</p> <p>24: 9.4 ←</p> <p>25: 9.9 ↗</p> <p>26: 9.7 ↑</p> <p>27: 9.2 →</p> <p>28: 9.8 →</p> <p>29: 10.3 ↑</p> <p>30: 10.3 ↓</p> <p>Series 87 (0x)</p> <p>263 (1x)</p> <p>31: 9.5 ↑</p> <p>32: 9.4 ↑</p> <p>33: 10.2 ↓</p> <p>34: 10.2 ↓</p> <p>35: 9.9 ←</p> <p>36: 9.6 ↗</p> <p>37: 9.5 →</p> <p>38: 9.7 ←</p> <p>39: 8.9 ←</p> <p>40: 8.2 ↓</p> <p>Series 90 (0x)</p> <p>353 (1x)</p>
<p>60 Shots</p> 	<p>60 Shots</p> 	<p>41: 10.6x ↙</p> <p>42: 10.3 →</p> <p>43: 8.8 ↓</p> <p>44: 9.8 ↑</p> <p>45: 10.1 →</p> <p>46: 7.8 ↓</p> <p>47: 10.4x ↓</p> <p>48: 9.0 ↘</p> <p>49: 10.2 ↑</p> <p>50: 8.6 ↓</p> <p>Series 91 (2x)</p> <p>444 (3x)</p> <p>51: 8.7 ↖</p> <p>52: 8.7 ↑</p> <p>53: 7.8 ↗</p> <p>54: 8.9 ↓</p> <p>55: 10.1 ↓</p> <p>56: 6.1 ←</p> <p>57: 10.1 ↙</p> <p>58: 7.9 ↓</p> <p>59: 8.9 ←</p> <p>60: 8.9 ↓</p> <p>Series 80 (0x)</p> <p>524 (3x)</p>

Relay **3** Lane **76** **PERRY Jack**

1-80 NTCSC Altius Pistol

31.01.2025 2025 AirNats by X Count Civilian Marksmanship Program

Comment Signature

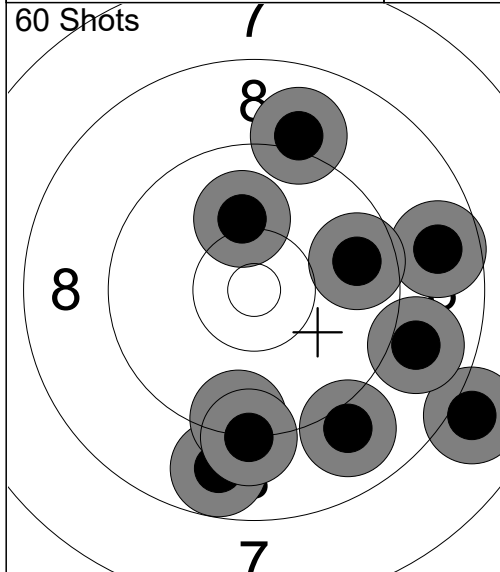

1:	10.1	↑
2:	8.8	↓
3:	8.7	→
4:	8.0	↘
5:	9.4	↓
6:	9.0	↘
7:	8.9	→
8:	9.7	→
9:	9.1	↑
10:	9.2	↓
Series	87 (0x)	
	87 (0x)	

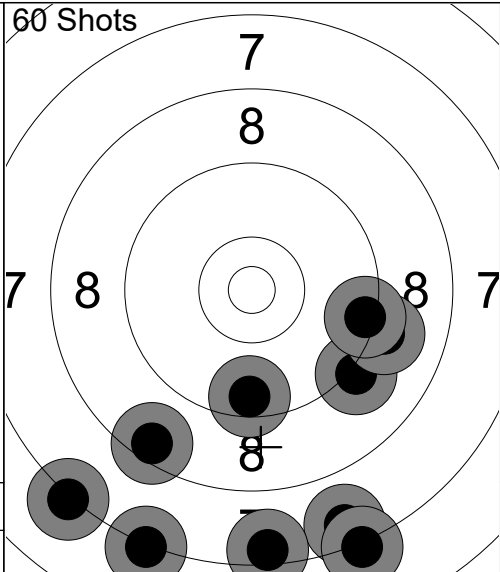

11:	7.5	↓
12:	9.1	↘
13:	7.4	↓
14:	9.5	↓
15:	9.1	→
16:	7.2	↙
17:	9.4	→
18:	7.2	↓
19:	7.2	↓
20:	8.5	↙
Series	79 (0x)	
	166 (0x)	

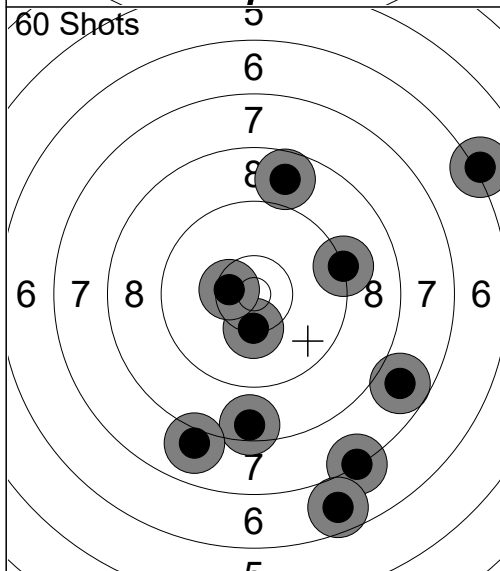

21:	6.1	→
22:	8.5	↓
23:	7.3	↓
24:	6.7	↓
25:	8.0	↓
26:	10.3	↓
27:	8.7	↑
28:	10.5x	←
29:	9.2	→
30:	7.8	↘
Series	79 (1x)	
	245 (1x)	

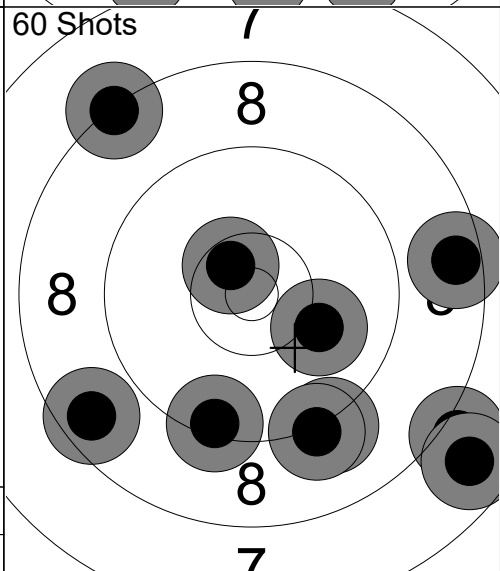

31:	10.1	→
32:	8.3	↗
33:	9.2	↓
34:	8.0	↘
35:	7.7	↘
36:	10.5x	↗
37:	9.4	↓
38:	8.5	→
39:	9.2	↓
40:	8.6	↙
Series	86 (1x)	
	331 (2x)	

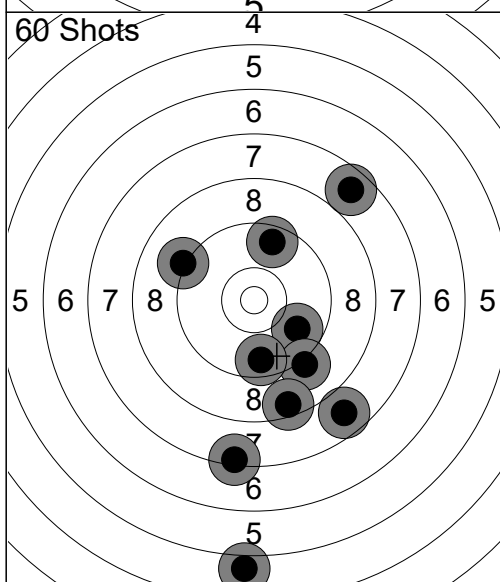

41:	9.2	↖
42:	7.7	↗
43:	9.8	↘
44:	9.1	↘
45:	4.9	↓
46:	9.6	↓
47:	7.7	↘
48:	7.3	↓
49:	8.5	↓
50:	9.6	↑
Series	78 (0x)	
	409 (2x)	

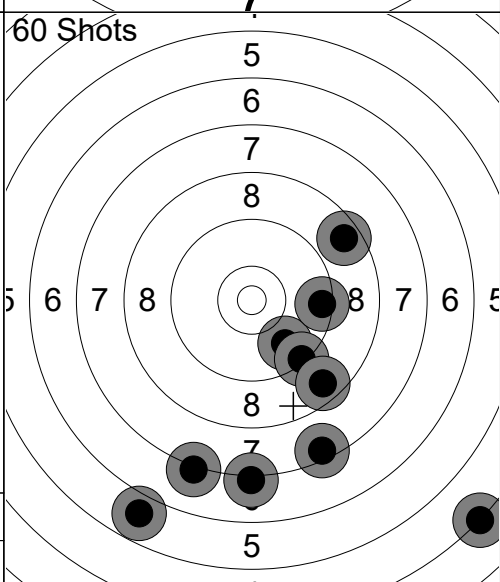

51:	9.8	↓
52:	9.5	→
53:	8.6	↗
54:	9.3	↘
55:	7.1	↓
56:	7.1	↓
57:	5.8	↙
58:	7.4	↙
59:	8.6	↙
60:	4.2	↘
Series	73 (0x)	
	482 (2x)	

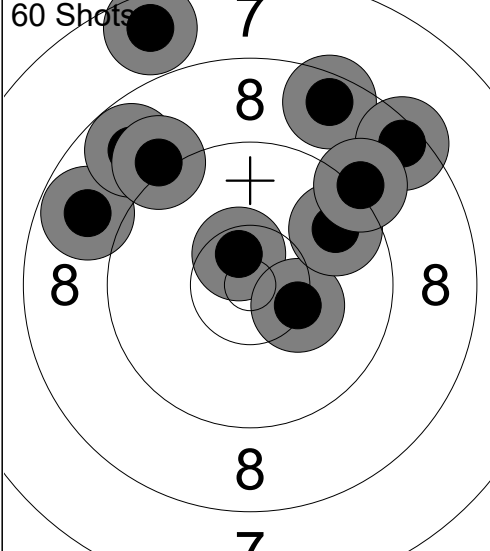
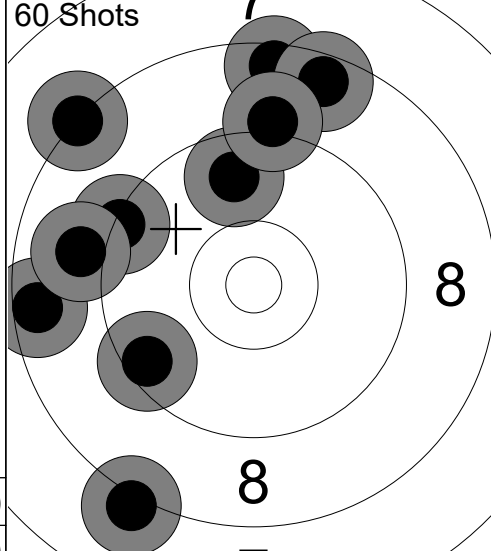
<p>60 Shots</p>  <p style="text-align: center;">7 8 8 8 8 7</p>	<p>1: 10.6x ↗</p> <p>2: 7.6 ↗</p> <p>3: 10.3 ➡</p> <p>4: 8.8 ↖</p> <p>5: 8.6 ↗</p> <p>6: 9.7 ➡</p> <p>7: 8.5 ➡</p> <p>8: 8.8 ↗</p> <p>9: 9.2 ➡</p> <p>10: 9.1 ↗</p> <hr/> <p>Series 86 (1x)</p> <p style="text-align: center;">86 (1x)</p>	<p>60 Shots</p>  <p style="text-align: center;">7 8 8 8 8 7</p>	<p>11: 8.5 ↗</p> <p>12: 9.3 ↖</p> <p>13: 8.5 ↗</p> <p>14: 8.1 ↘</p> <p>15: 9.5 ↖</p> <p>16: 9.7 ↗</p> <p>17: 8.5 ↖</p> <p>18: 9.0 ↖</p> <p>19: 8.3 ↖</p> <p>20: 9.1 ↗</p> <hr/> <p>Series 85 (0x)</p> <p style="text-align: center;">171 (1x)</p>
---	--	---	---

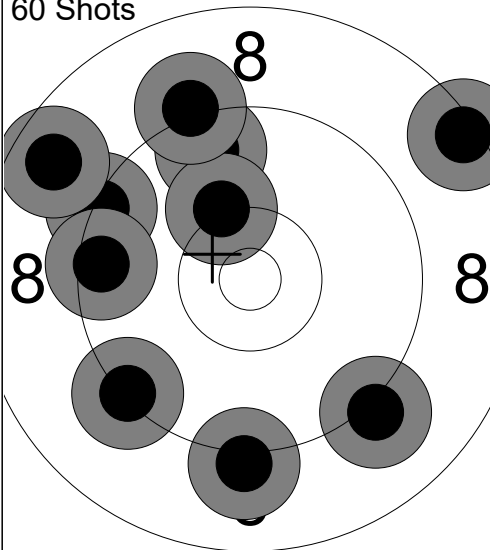
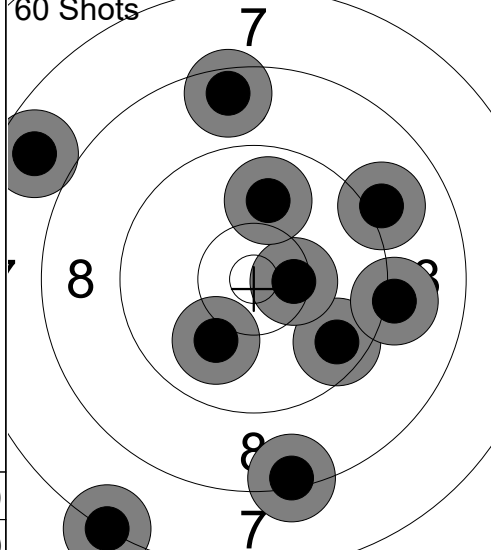
<p>60 Shots</p>  <p style="text-align: center;">8 8 8 8 8 7</p>	<p>21: 9.3 ↖</p> <p>22: 9.6 ↗</p> <p>23: 9.3 ↖</p> <p>24: 8.7 ↗</p> <p>25: 9.1 ↘</p> <p>26: 9.1 ↘</p> <p>27: 9.5 ↖</p> <p>28: 10.2 ↗</p> <p>29: 8.4 ➡</p> <p>30: 9.1 ↗</p> <hr/> <p>Series 89 (0x)</p> <p style="text-align: center;">260 (1x)</p>	<p>60 Shots</p>  <p style="text-align: center;">7 8 8 8 8 7</p>	<p>31: 7.2 ↘</p> <p>32: 9.6 ➡</p> <p>33: 10.0 ↘</p> <p>34: 9.1 ➡</p> <p>35: 10.4x ➡</p> <p>36: 9.1 ➡</p> <p>37: 8.5 ↗</p> <p>38: 8.4 ↘</p> <p>39: 9.9 ↗</p> <p>40: 7.7 ↖</p> <hr/> <p>Series 86 (1x)</p> <p style="text-align: center;">346 (2x)</p>
--	--	--	--

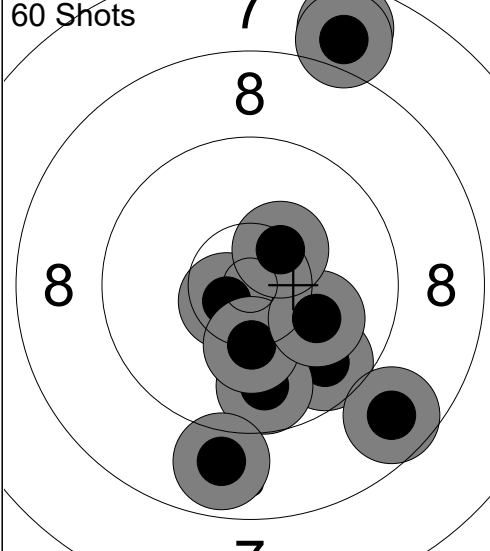
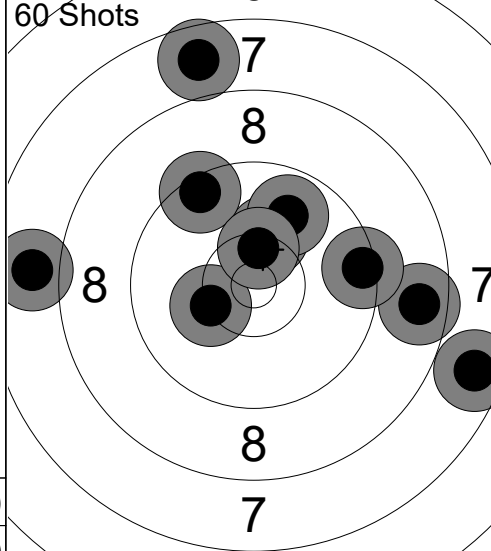
<p>60 Shots</p>  <p style="text-align: center;">7 8 8 8 8 7</p>	<p>41: 7.8 ↗</p> <p>42: 7.9 ↗</p> <p>43: 10.6x ↖</p> <p>44: 9.7 ↘</p> <p>45: 9.8 ↘</p> <p>46: 8.7 ↘</p> <p>47: 10.3 ↘</p> <p>48: 8.9 ↘</p> <p>49: 10.1 ➡</p> <p>50: 10.4x ↗</p> <hr/> <p>Series 88 (2x)</p> <p style="text-align: center;">434 (4x)</p>	<p>60 Shots</p>  <p style="text-align: center;">7 8 8 8 8 7</p>	<p>51: 7.9 ↖</p> <p>52: 10.2 ↗</p> <p>53: 10.3 ↖</p> <p>54: 7.7 ↗</p> <p>55: 8.6 ➡</p> <p>56: 7.6 ➡</p> <p>57: 9.5 ↗</p> <p>58: 9.9 ↗</p> <p>59: 9.4 ➡</p> <p>60: 10.4x ↗</p> <hr/> <p>Series 86 (1x)</p> <p style="text-align: center;">520 (5x)</p>
---	---	---	---

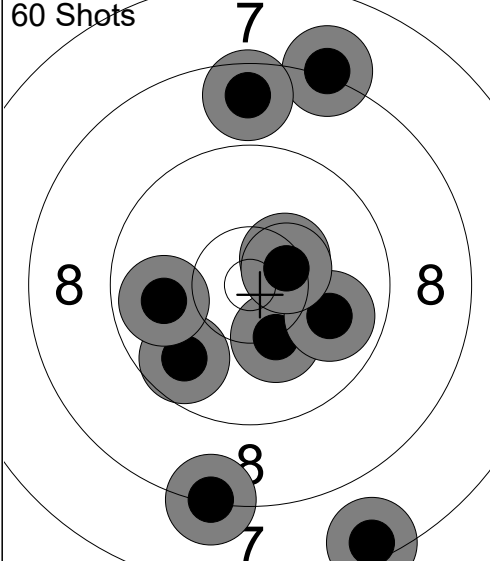
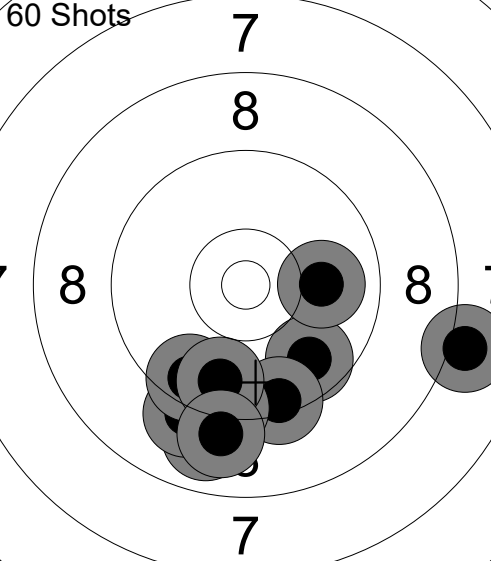
<p>60 Shots</p> 	<p>1: 8.2 ↗ 2: 8.6 ↑ 3: 9.7 ↘ 4: 10.2 ↓ 5: 9.9 ➡ 6: 10.4x ↗ 7: 10.5x ↗ 8: 7.4 ↓ 9: 8.3 ↓ 10: 9.9 ←</p> <p>Series 88 (2x) 88 (2x)</p>	<p>60 Shots</p> 	<p>11: 9.7 ↘ 12: 9.4 ↓ 13: 8.9 ↓ 14: 9.1 ↓ 15: 9.4 ↓ 16: 10.0 → 17: 9.6 ↓ 18: 9.7 ↓ 19: 8.0 ➡ 20: 9.0 ↓</p> <p>Series 89 (0x) 177 (2x)</p>
--	--	--	--

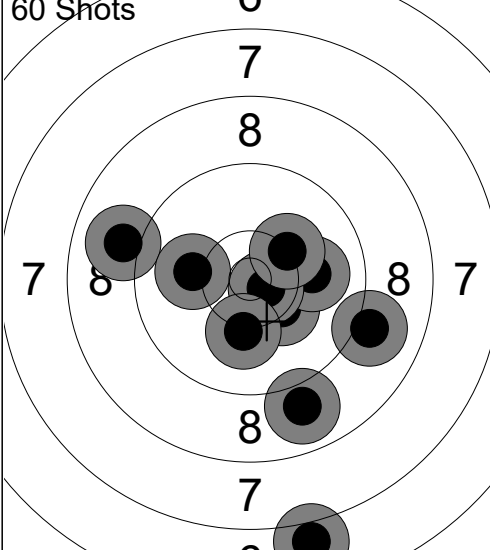
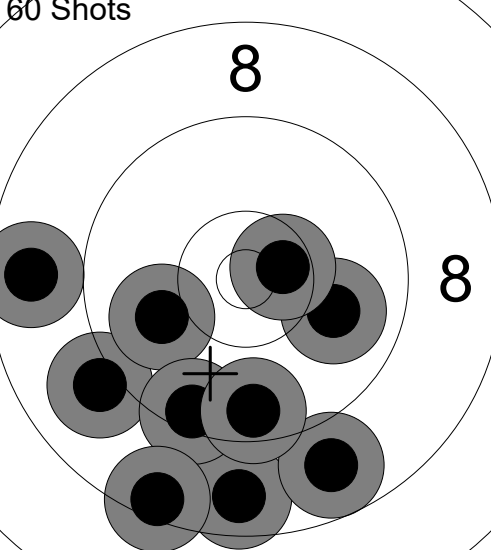
<p>60 Shots</p> 	<p>21: 10.3 ↓ 22: 10.0 → 23: 10.7x ➡ 24: 10.2 ↓ 25: 8.9 ↓ 26: 10.3 ↗ 27: 6.9 ↓ 28: 9.0 ➡ 29: 9.0 ← 30: 10.1 ←</p> <p>Series 92 (1x) 269 (3x)</p>	<p>60 Shots</p> 	<p>31: 10.0 ➡ 32: 10.5x ➡ 33: 9.0 ← 34: 10.0 ← 35: 8.7 ↓ 36: 9.4 ↓ 37: 8.8 ↓ 38: 9.6 ↓ 39: 8.4 ↓ 40: 8.7 ←</p> <p>Series 89 (1x) 358 (4x)</p>
---	--	---	---

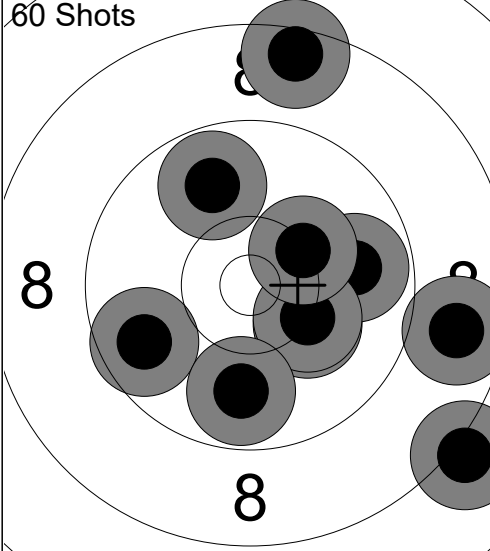
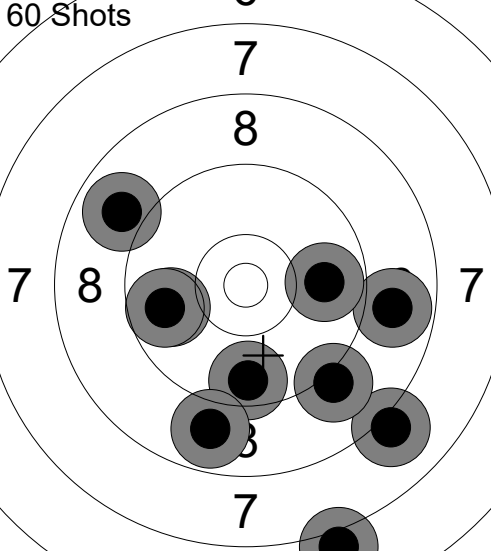
<p>60 Shots</p> 	<p>41: 9.8 ↗ 42: 10.2 ↓ 43: 8.7 ➡ 44: 9.8 ➡ 45: 10.3 ↓ 46: 9.7 ← 47: 8.5 ↑ 48: 9.8 ↓ 49: 8.1 ↓ 50: 10.3 ↗</p> <p>Series 90 (0x) 448 (4x)</p>	<p>60 Shots</p> 	<p>51: 8.1 ↓ 52: 8.9 ↗ 53: 9.6 ↓ 54: 9.8 ← 55: 8.9 ↓ 56: 8.8 ➡ 57: 9.8 ➡ 58: 9.8 ← 59: 7.0 ↓ 60: 9.1 ↓</p> <p>Series 84 (0x) 532 (4x)</p>
--	--	--	---

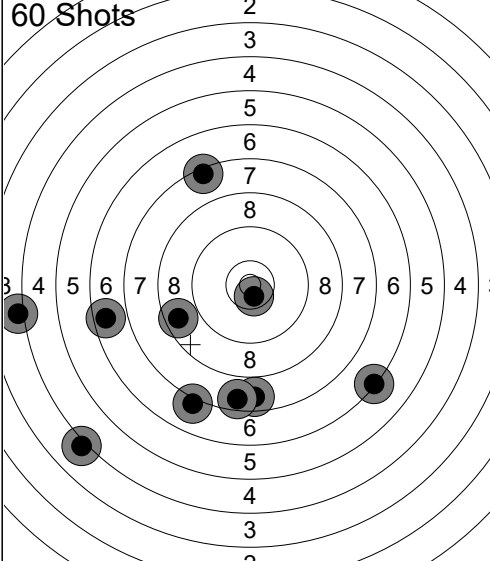
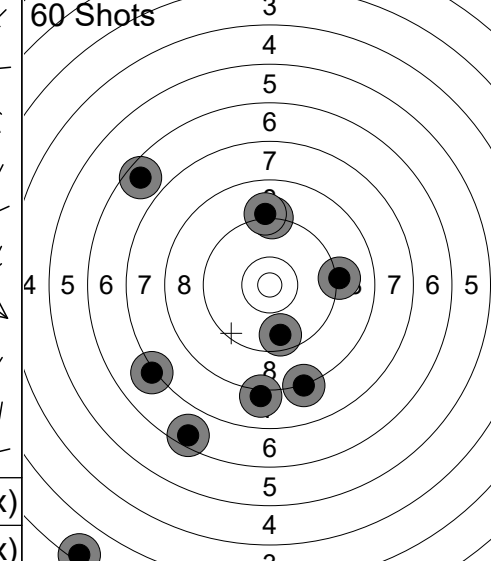
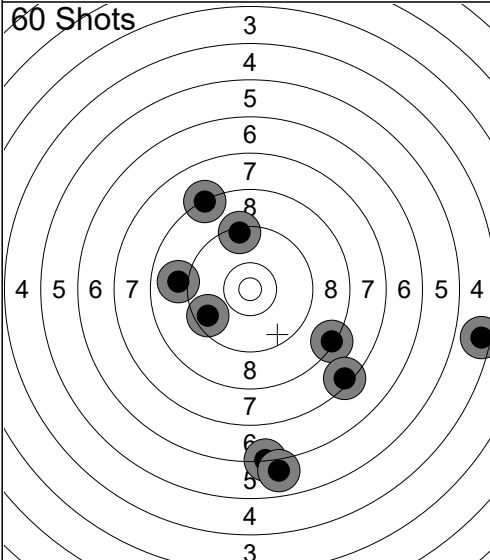
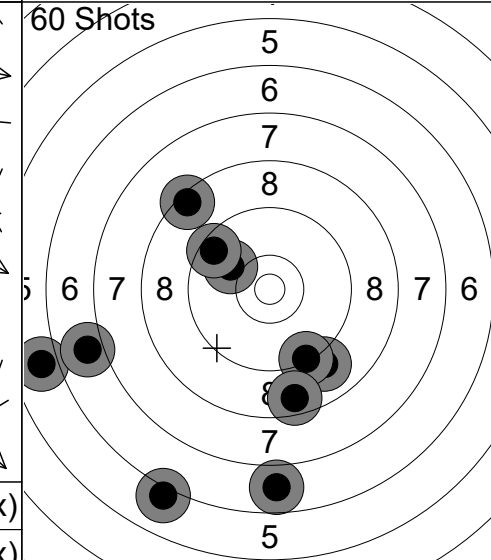
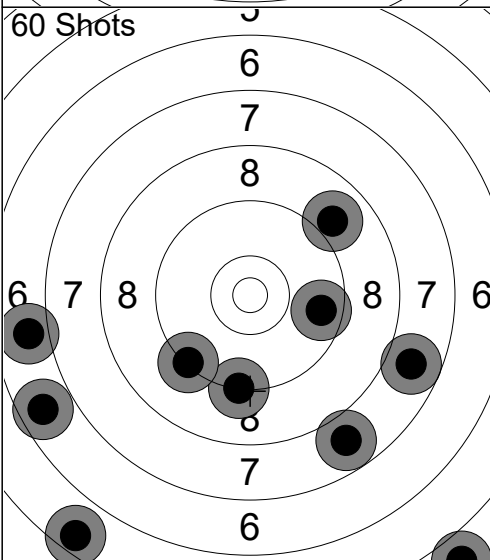
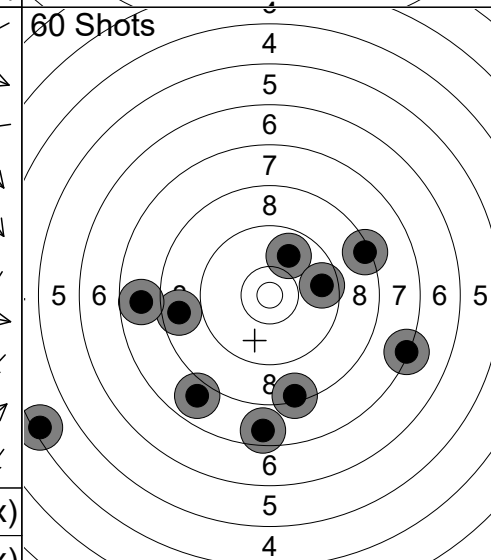
<p>60 Shots</p>  <p>1: 4.1 ↙ 2: 4.1 ← 3: 7.4 ↗ 4: 7.6 ↓ 5: 8.6 ← 6: 7.1 ↓ 7: 6.3 ↘ 8: 7.6 ↓ 9: 10.6x ↓ 10: 6.6 ←</p> <p>Series 66 (1x) 66 (1x)</p>	<p>60 Shots</p>  <p>11: 8.1 ↓ 12: 9.6 ↓ 13: 6.6 ↖ 14: 9.2 ↑ 15: 9.1 → 16: 9.1 ↑ 17: 2.4 ↓ 18: 6.5 ↓ 19: 8.2 ↓ 20: 7.1 ↙</p> <p>Series 73 (0x) 139 (1x)</p>
<p>60 Shots</p>  <p>21: 9.4 ↑ 22: 4.5 → 23: 9.0 ← 24: 6.3 ↓ 25: 8.2 ↗ 26: 8.3 ↘ 27: 0.0 28: 5.9 ↓ 29: 9.6 ← 30: 7.4 ↘</p> <p>Series 65 (0x) 204 (1x)</p>	<p>60 Shots</p>  <p>31: 10.0 ↖ 32: 6.0 ↓ 33: 9.0 ↓ 34: 6.8 ↓ 35: 8.4 ↗ 36: 9.3 ↓ 37: 5.9 ← 38: 9.5 ↗ 39: 6.9 ← 40: 8.6 ↓</p> <p>Series 76 (0x) 280 (1x)</p>
<p>60 Shots</p>  <p>41: 6.6 ← 42: 7.8 → 43: 6.9 ← 44: 4.8 ↘ 45: 7.8 ↓ 46: 9.3 ↓ 47: 9.6 → 48: 9.3 ↖ 49: 8.9 ↗ 50: 5.6 ↘</p> <p>Series 70 (0x) 350 (1x)</p>	<p>60 Shots</p>  <p>51: 7.9 ↘ 52: 9.9 ↑ 53: 9.6 → 54: 7.3 → 55: 7.6 ↓ 56: 8.4 → 57: 4.4 ← 58: 8.7 ← 59: 8.4 ↓ 60: 7.8 ←</p> <p>Series 74 (0x) 424 (1x)</p>